

ACADEMIC  
YEAR 2016-17



A00120636

# PHYSICS

# 12

2016-17



PUNJAB CURRICULUM AND  
TEXTBOOK BOARD, LAHORE





All rights reserved with the Punjab Curriculum & Textbook Board, Lahore.  
 Approved by the Federal Ministry of Education, Islamabad.  
 Vide Letter No. F. 6- 4 / 2002 (b.s) dated 27 May 2003  
 Government of Pakistan, Islamabad.

### CONTENTS

Sr. No.	Chapter	Page
12.	Electrostatics	1
13.	Current Electricity	31
14. 135818	Electromagnetism	56
15.	Electromagnetic Induction	81
16.	Alternating Current	111
17.	Physics of Solids	135
18.	Electronics	154
19.	Dawn of Modern Physics	175
20.	Atomic Spectra	202
21.	Nuclear Physics	219
i.	Glossary	260
ii.	Bibliography	264
iii.	Index	265

### AUTHORS

**Prof. Dr. Mrs. Fouzia Saleemi**  
 Sitara-i-Imtiaz, Izaz-i-Fazcelat

**Prof. Dr. M. Zakria Butt**  
 Tamgha-i-Imtiaz

**Prof. Naseer Ahmad Qureshi (Rtd.)**

**Prof. Muhammad Nisar**

**Prof. Dr. Muhammad Rafiq**

**Prof. Muhammad Nawaz Khan**

**Prof. Muhammad Ali Shahid**  
 Izaz-i-Fazcelat

**Prof. Sh. Aftab Ahmad (Rtd.)**

**Prof. S. M. Akhtar (Rtd.)**

**Prof. Dr. Ijaz Mujtaba Ghauri**

**Dr. Muhammad Rafiq Sahi (Rtd.)**

### EDITORS

**Prof. Muhammad Ali Shahid**  
 Izaz-i-Fazcelat

**Prof. Sh. Aftab Ahmad (Rtd.)**

**Prof. Dr. Mrs. Fouzia Saleemi**  
 Sitara-i-Imtiaz, Izaz-i-Fazcelat

### SUPERVISION

**Qaiser Saleem**

Published by: **Seith Adam Jee Abdullah, Lahore**

Printed by: **Nasab Printers, Lahore.**

Date of Printing	Edition	Impression	No. of Copies	Price
May 2016	1st	25th	17,000	115.00



# Chapter 12

## ELECTROSTATICS

### Learning Objectives

At the end of this chapter the students will be able to:

1. Understand and describe Coulomb's law.
2. Describe that a charge has a field of force around it.
3. Understand fields of like and unlike charges.
4. Appreciate the principle of inkjet printers and photostat copier as an application of electrostatic phenomena.
5. Explain the electric intensity in a free space and in other media.
6. State and prove Gauss's law.
7. Appreciate the applications of Gauss's law.
8. Explain electric potential at a point in terms of work done in bringing a unit positive charge from infinity to that point.
9. Relate electric field strength and potential gradient.
10. Find expression for potential at a point due to a point charge.
11. Describe and derive the value of electric charge by Millikan's method.
12. Calculate the capacitance of parallel plate capacitor.
13. Recognize the effect of dielectric on the capacitance of parallel plate capacitor.
14. Understand and describe electric polarization of dielectric.
15. Know the process of charging and discharging of a capacitor through a resistance and calculate the time constant.
16. Find energy expression of a charged capacitor.

**T**he study of electric charges at rest under the action of electric forces is known as electrostatics. An electric force is the force which holds the positive and negative charges that make up atoms and molecules. The human body is composed entirely of atoms and molecules, thus we owe our existence to the electric force.





A lightning flash

## 12.1 COULOMB'S LAW

We know that there are two kinds of charges, namely, positive and negative charges. The charge on an electron is assumed to be negative and charge on a proton is positive. Moreover, we also learnt that like charges repel each other and unlike charges attract each other. Now we investigate the quantitative nature of these forces. The first measurement of the force between electric charges was made in 1784 AD by Charles Coulomb, a French military engineer. On the basis of these measurements, he deduced a law known as Coulomb's law. It states that

The force between two point charges is directly proportional to the product of the magnitudes of charges and inversely proportional to the square of the distance between them. It is mathematically expressed as

$$F \propto \frac{q_1 q_2}{r^2} \quad \text{or} \quad F = k \frac{q_1 q_2}{r^2} \quad \dots \dots \dots (12.1)$$

where  $F$  is the magnitude of the mutual force that acts on each of the two point charges  $q_1$ ,  $q_2$  and  $r$  is the distance between them. The force  $F$  always acts along the line joining the two point charges (Fig. 12.1),  $k$  is the constant of proportionality. Its value depends upon the nature of medium between the two charges and system of units in which  $F$ ,  $q$  and  $r$  are measured. If the medium between the two point charges is free space and the system of units is SI, then  $k$  is represented as

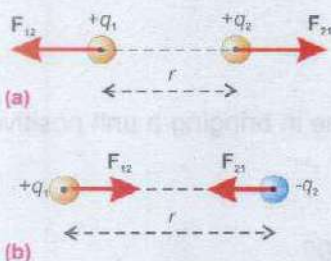
$$k = \frac{1}{4\pi\epsilon_0} \quad \dots \dots \dots (12.2)$$

where  $\epsilon_0$  is an electrical constant, known as permittivity of free space. In SI units, its value is  $8.85 \times 10^{-12} \text{ C}^2 \text{ N}^{-1} \text{ m}^{-2}$ . Substituting the value of  $\epsilon_0$ , the constant

$$k = \frac{1}{4\pi\epsilon_0} = 9 \times 10^9 \text{ Nm}^2 \text{ C}^{-2}$$

Thus Coulomb's force in free space is

$$F = \frac{1}{4\pi\epsilon_0} \frac{q_1 q_2}{r^2} \quad \dots \dots \dots (12.3)$$



**Fig 12.1** (a) Repulsive forces between like charges and (b) attractive forces between unlike charges



As stated earlier, Coulombs' force is mutual force, it means that if  $q_1$  exerts a force on  $q_2$ , then  $q_2$  also exerts an equal and opposite force on  $q_1$ . If we denote the force exerted on  $q_2$  by  $q_1$  as  $F_{21}$  and that on charge  $q_1$  due to  $q_2$  as  $F_{12}$ , then

$$F_{12} = -F_{21} \quad \dots\dots\dots (12.4)$$

The magnitude of both these two forces is the same and is given by Eq. 12.3. To represent the direction of these forces we introduce unit vectors. If  $\hat{r}_{21}$  is the unit vector directed from  $q_1$  to  $q_2$  and  $\hat{r}_{12}$  is the unit vector directed from  $q_2$  to  $q_1$ , then

$$F_{21} = \frac{1}{4\pi\epsilon_0} \frac{q_1 q_2}{r^2} \hat{r}_{21} \quad \dots\dots\dots 12.5 (a)$$

and

$$F_{12} = \frac{1}{4\pi\epsilon_0} \frac{q_1 q_2}{r^2} \hat{r}_{12} \quad \dots\dots\dots 12.5 (b)$$

The forces  $F_{21}$  and  $F_{12}$  are shown in Fig. 12.2 (a & b). It can be seen that  $\hat{r}_{21} = -\hat{r}_{12}$ , so Eqs. 12.5 (a & b) show that

$$F_{21} = -F_{12}$$

The sign of the charges in Eqs. 12.5 (a & b) determine whether the forces are attractive or repulsive.

We shall now consider the effect of medium between the two charges upon the Coulomb's force. If the medium is an insulator, it is usually referred as dielectric. It has been found that the presence of a dielectric always reduces the electrostatic force as compared with that in free space by a certain factor which is a constant for the given dielectric. This constant is known as relative permittivity and is represented by  $\epsilon_r$ . The values of relative permittivity of different dielectrics are given in Table 12.1.

Thus the Coulomb's force in a medium of relative permittivity  $\epsilon_r$  is given by

$$F = \frac{1}{4\pi\epsilon_0\epsilon_r} \frac{q_1 q_2}{r^2} \quad \dots\dots\dots (12.6)$$

It can be seen in the table that  $\epsilon_r$  for air is 1.0006. This value is so close to one that with negligible error, the Eq. 12.3 gives the electric force in air.

**Example 12.1:** Charges  $q_1 = 100 \mu\text{C}$  and  $q_2 = 50 \mu\text{C}$  are located in xy-plane at positions  $r_1 = 3.0\hat{j}$  and  $r_2 = 4.0\hat{i}$  respectively,

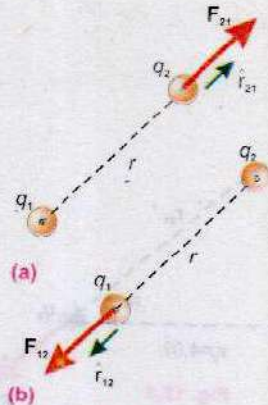
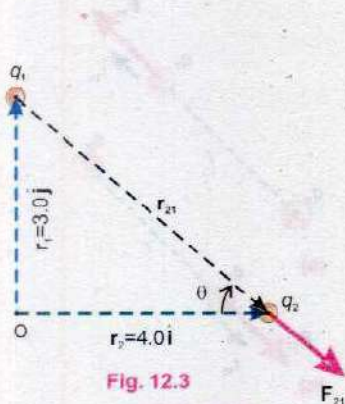


Fig. 12.2

Table 2.1

Material	$\epsilon_r$
Vacuum	1
Air (1 atm)	1.0006
Ammonia (liquid)	22-25
Bakelite	5-18
Benzene	2.284
Germanium	16
Glass	4.8-10
Mica	3-7.5
Paraffined paper	2
Plexiglas	3.40
Rubber	2.94
Teflon	2.1
Transformer oil	2.1
Water (distilled)	78.5





where the distances are measured in metres. Calculate the force on  $q_2$  (Fig. 12.3).

**Solution:**  $q_1 = 100 \mu\text{C}$ ,  $q_2 = 50 \mu\text{C}$

Position vector of  $q_2$  relative to  $q_1$

$$= \mathbf{r}_{21} = \mathbf{r}_2 - \mathbf{r}_1 = 4\mathbf{i} - 3\mathbf{j}$$

$$r = \text{magnitude of } \mathbf{r}_{21} = \sqrt{(4\text{m})^2 + (-3\text{m})^2} = 5\text{m}$$

$$\hat{\mathbf{r}}_{21} = \frac{4\mathbf{i} - 3\mathbf{j}}{5}$$

$$\mathbf{F}_{21} = \frac{1}{4\pi\epsilon_0} \frac{q_1 q_2}{r^2} \hat{\mathbf{r}}_{21}$$

$$= \frac{9 \times 10^9 \text{ Nm}^2\text{C}^{-2} \times 100 \times 10^{-6} \text{ C} \times 50 \times 10^{-6} \text{ C}}{(5\text{m})^2} \times \frac{4\mathbf{i} - 3\mathbf{j}}{5}$$

$$= 1.44\mathbf{i} - 1.08\mathbf{j}$$

$$\text{Magnitude of } \mathbf{F}_{21} = F = \sqrt{(1.44)^2 + (-1.08)^2} = 1.8 \text{ N}$$

$$\text{Direction of } \mathbf{F}_{21} = \tan^{-1} \left( \frac{-1.08}{1.44} \right) = -37^\circ \text{ with x-axis}$$

## 12.2 FIELDS OF FORCE

Newton's universal gravitational law and Coulomb's law enable us to calculate the magnitude as well as the directions of the gravitational and electric forces, respectively. However one may question, (a) What are the origins of these forces? (b) How are these forces transmitted from one mass to another or from one charge to another?

The answer to (a) is still unknown; the existence of these forces is accepted as it is. That is why they are called basic forces of nature.

To describe the mechanism by which electric force is transmitted, Michael Faraday (1791-1867) introduced the concept of an electric field. According to his theory, it is the intrinsic property of nature that an electric field exists in the space around an electric charge. This electric field is considered to be a force field that exerts a force on other charges placed in that field. For example, a charge  $q$  produces an electric field in the space surrounding it. This



field exists whether the other charges are present in space or not. However, the presence of field cannot be tested until another charge  $q_0$  is brought into the field. Thus the field of charge  $q$  interacts with  $q_0$  to produce an electrical force. The interaction between  $q$  and  $q_0$  is accomplished in two steps: (a) the charge  $q$  produces a field and (b) the field interacts with charge  $q_0$  to produce a force  $\mathbf{F}$  on  $q_0$ . These two steps are illustrated in Fig. 12.4.

In this figure the density of dots is proportional to the strength of the field at the various points. We may define electric field strength or electric field intensity  $\mathbf{E}$  at any point in the field as

$$\mathbf{E} = \frac{\mathbf{F}}{q_0} \quad \dots \dots \dots \quad (12.7)$$

where  $\mathbf{F}$  is the force experienced by a positive test charge  $q_0$  placed at the point. The test charge  $q_0$  has to be very small so that it may not distort the field which it has to measure.

Since electric field intensity is force per unit charge, it is measured in newton per coulomb in SI units. It is a vector quantity and its direction is the same as that of the force  $\mathbf{F}$ .

The force experienced by a test charge  $q_0$  placed in the field of a charge  $q$  in vacuum is given by Eq. (12.3). Eq. 12.7 can be used to evaluate electric intensity due to a point charge  $q$  at a point distant  $r$  from it. Place a positive test charge  $q_0$  at this point. The Coulomb's force that this charge will experience due to  $q$  is

$$\mathbf{F} = \frac{1}{4\pi\epsilon_0} \frac{qq_0}{r^2} \hat{\mathbf{r}} \quad \dots \dots \dots \quad (12.8)$$

where  $\hat{\mathbf{r}}$  is a unit vector directed from the point charge  $q$  to the test point where  $q_0$  has been placed, i.e., the point where the electric intensity is to be evaluated. By Eq. 12.7

$$\mathbf{E} = \frac{\mathbf{F}}{q_0} = \frac{1}{4\pi\epsilon_0} \frac{qq_0}{r^2} \hat{\mathbf{r}} \times \frac{1}{q_0} = \frac{1}{4\pi\epsilon_0} \frac{q}{r^2} \hat{\mathbf{r}} \quad \dots \dots \dots \quad (12.9)$$

**Example 12.2:** Two positive point charges  $q_1 = 16.0 \mu\text{C}$  and  $q_2 = 4.0 \mu\text{C}$  are separated by a distance of 3.0 m, as shown in Fig. 12.5. Find the spot on the line joining the two charges where electric field is zero.

**Solution:** Between the charges, the two field contribution has opposite directions, and electric field would be zero at a

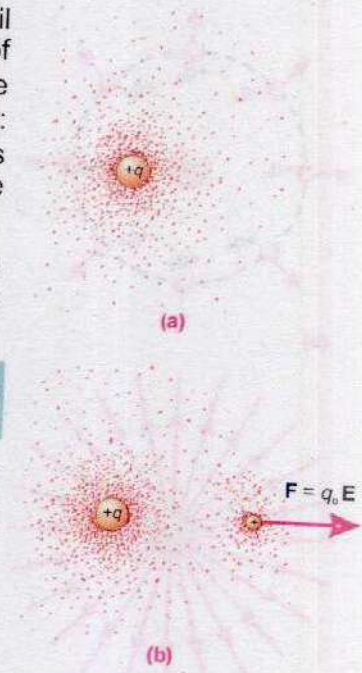


Fig. 12.4 (a) Dots surrounding the positive charge indicate the presence of the electric field. The density of dots is proportional to the strength of the electric field at different points. (b) Interaction of the field with the charge  $q_0$ .

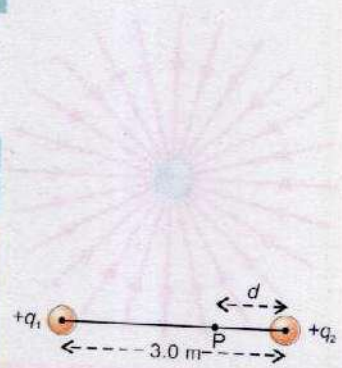
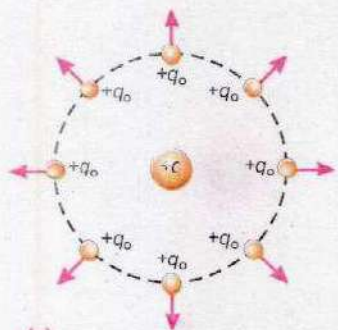
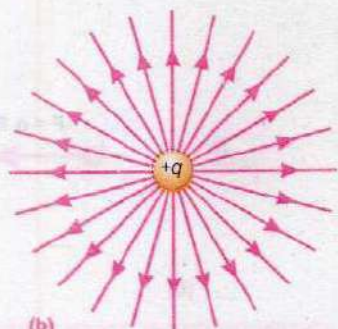


Fig. 12.5



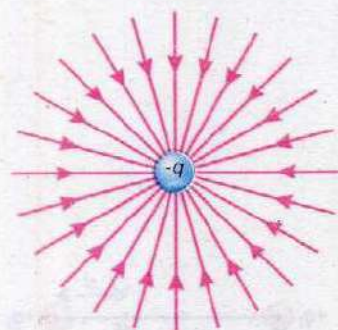


(a)



(b)

**Fig. 12.6 (a)** A positive test charge  $+q_0$  placed anywhere in the vicinity of a positive point charge  $+q$ , experiences a repulsive force directed radially outward. **(b)** The electric field lines are directed radially outward from the positive point charge  $+q$ .



**Fig. 12.7** The electric field lines are directed radially inward towards a negative point charge  $-q$ .

point P, where the magnitude of  $E_1$  equals that of  $E_2$ . In the Fig. 12.5, let the distance of P from  $q_2$  be  $d$ .

At P,  $E_1 = E_2$ , which implies that,

$$\frac{1}{4\pi\epsilon_0} \frac{q_1}{(3.0 - d)^2} = \frac{1}{4\pi\epsilon_0} \frac{q_2}{d^2}$$

or

$$\frac{16.0 \times 10^{-6} \text{ C}}{9 + d^2 - 6d} = \frac{4.0 \times 10^{-6} \text{ C}}{d^2}$$

or

$$d^2 + 2d - 3 = 0, \text{ which gives } d = +1 \text{ m}, -3 \text{ m}$$

There are two possible values of  $d$ , the negative value corresponds to a location off to the right of both the charges where magnitudes of  $E_1$  and  $E_2$  are equal but directions are same. In this case  $E_1$  and  $E_2$  do not cancel at this spot. The positive value corresponds to the location shown in figure and is the zero field location, hence,  $d = +1.0 \text{ m}$ .

### 12.3 ELECTRIC FIELD LINES

A visual representation of the electric field can be obtained in terms of electric field lines; an idea proposed by Michael Faraday. Electric field lines can be thought of a "map" that provides information about the direction and strength of the electric field at various places. As electric field lines provide information about the electric force exerted on a charge, the lines are commonly called "lines of force".

To introduce electric field lines, we place positive test charges each of magnitude  $q_0$  at different places but at equal distances from a positive charge  $+q$  as shown in the figure. Each test charge will experience a repulsive force, as indicated by arrows in Fig. 12.6(a). Therefore, the electric field created by the charge  $+q$  is directed radially outward. Fig. 12.6 (b) shows corresponding field lines which show the field direction. Fig. 12.7 shows the electric field lines in the vicinity of a negative charge  $-q$ . In this case the lines are directed radially "inward", because the force on a positive test charge is now of attraction, indicating the electric field points inward.

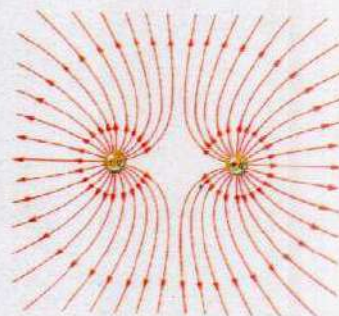
Figures 12.6 and 12.7 represent two dimensional pictures of the field lines. However, electric field lines emerge from the charges in three dimensions, and an infinite number of lines could be drawn.

The electric field lines "map" also provides information about



the strength of the electric field. As we notice in Figs. 12.6 and 12.7 that field lines are closer to each other near the charges where the field is strong while they continuously spread out indicating a continuous decrease in the field strength.

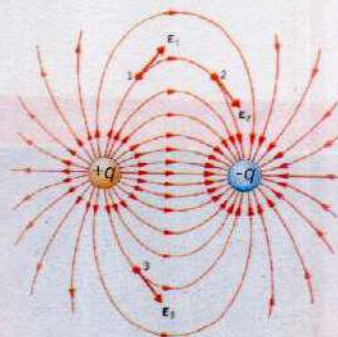
**"The number of lines per unit area passing perpendicularly through an area is proportional to the magnitude of the electric field".**



**Fig. 12.8** The electric field lines for two identical positive point charges.

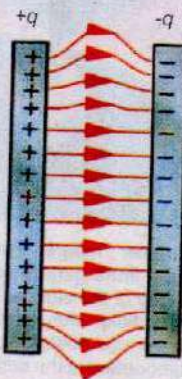
The electric field lines are curved in case of two identical separated charges. Fig.12.8 shows the pattern of lines associated with two identical positive point charges of equal magnitude. It reveals that the lines in the region between two like charges seem to repel each other. The behaviour of two identical negatively charges will be exactly the same. The middle region shows the presence of a zero field spot or neutral zone.

The Fig.12.9 shows the electric field pattern of two opposite charges of same magnitudes. The field lines start from positive charge and end on a negative charge. The electric field at points such as 1, 2, 3 is the resultant of fields created by the two charges at these points. The directions of the resultant intensities is given by the tangents drawn to the field lines at these points.



**Fig. 12.9** Attractive forces between unlike charges

In the regions where the field lines are parallel and equally spaced, the same number of lines pass per unit area and therefore, field is uniform on all points. Fig.12.10 shows the field lines between the plates of a parallel plate capacitor. The field is uniform in the middle region where field lines are equally spaced.



**Fig. 12.10** In the central region of a parallel plate capacitor the electric field lines are parallel and evenly spaced, indicating that the electric field there has the same magnitude and direction at all points.

We are now in a position to summarize the properties of electric field lines.

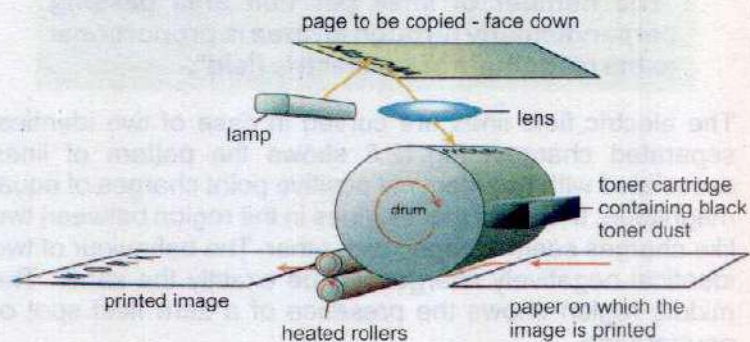
- 1) Electric field lines originate from positive charges and end on negative charges.
- 2) The tangent to a field line at any point gives the direction of the electric field at that point.
- 3) The lines are closer where the field is strong and the lines are farther apart where the field is weak.
- 4) No two lines cross each other. This is because  $\mathbf{E}$  has only one direction at any given point. If the lines cross,  $\mathbf{E}$  could have more than one direction.



## 12.4 APPLICATIONS OF ELECTROSTATICS

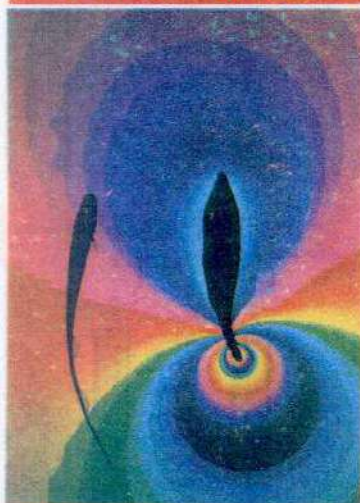
### (i) Xerography (Photocopier)

Fig.12.11 illustrates a photocopy machine. The copying



**Fig. 12.11** The basics of photocopying. The lamp transfers an image of the page to the drum, which leaves a static charge. The drum collects toner dust and transfers it to the paper. The toner is melted onto the page.

### For Your Information



This computer image shows the electric field lines generated by the fish at the top of the picture. Through the electric field, the presence of other fish can be detected, such as the one silhouetted at the bottom.

process is called xerography, from the Greek word "xeros" and "graphos", meaning "dry writing". The heart of machine is a drum which is an aluminium cylinder coated with a layer of selenium. Aluminium is an excellent conductor. On the other hand, selenium is an insulator in the dark and becomes a conductor when exposed to light; it is a photoconductor. As a result, if a positive charge is sprinkled over the selenium it will remain there as long as it remains in dark. If the drum is exposed to light, the electrons from aluminium pass through the conducting selenium and neutralize the positive charge.

If the drum is exposed to an image of the document to be copied, the dark and light areas of the document produce corresponding areas on the drum. The dark areas retain their positive charge, but light areas become conducting, lose their positive charge and become neutral.

In this way, a positive charge image of the document remains on the selenium surface. Then a special dry, black powder called "toner" is given a negative charge and spread over the drum, where it sticks to the positive charged areas.

The toner from the drum is transferred on to a sheet of paper on which the document is to be copied. Heated pressure



rollers then melt the toner into the paper which is also given an excess positive charge to produce the permanent impression of the document.

## (ii) Inkjet Printers

An inkjet printer (Fig. 12.12 a) is a type of printer which uses electric charge in its operation. While shuttling back and forth across the paper, the inkjet printer "ejects" a thin stream of ink. The ink is forced out of a small nozzle and breaks up into extremely small droplets. During their flight, the droplets pass through two electrical components, a "charging electrode" and the "deflection plates" (a parallel plate capacitor). When the printhead moves over regions of the paper which are not to be inked, the charging electrode is left on and gives the ink droplets a net charge. The deflection plates divert such charged drops into a gutter and in this way such drops are not able to reach the paper. Whenever ink is to be placed on the paper, the charging control, responding to computer, turns off the charging electrode. The uncharged droplets fly straight through the deflection plates and strike the paper. Schematic diagram of such a printer is shown by Fig. 12.12 (b).

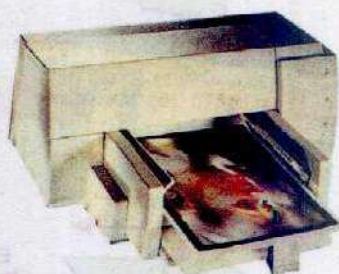


Fig. 12.12 (a) An inkjet printer.

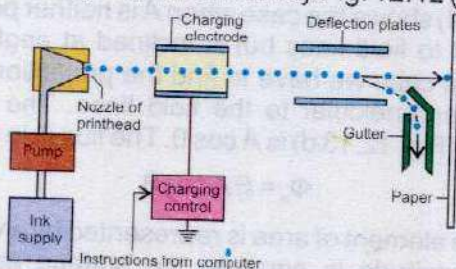


Fig. 12.12 (b) An inkjet printhead ejects a steady flow of ink droplets. The charging electrodes are used to charge the droplets that are not needed on the paper. Charged droplets are deflected into a gutter by the deflection plates, while uncharged droplets fly straight onto the paper.

Inkjet printers can also produce coloured copies.

## 12.5 ELECTRIC FLUX

When we place an element of area in an electric field, some of the lines of force pass through it (Fig. 12.13 a).

The number of the field lines passing through a certain element of area is known as electric flux through that area. It is usually denoted by Greek letter  $\Phi$ . For example the flux  $\Phi$  through the area A in Fig. 12.13 (a) is 4 while the flux through B is 2.

In order to give a quantitative meaning to flux, the field lines are drawn such that the number of field lines passing through

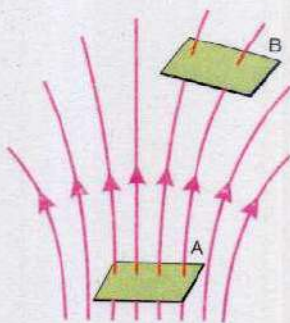


Fig. 12.13 (a) Electric flux through a surface normal to E.



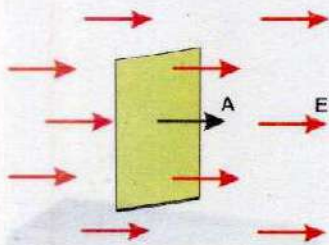


Fig. 12.13 (b) Maximum

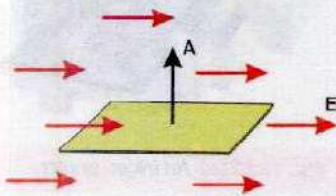


Fig. 12.13 (c) Minimum

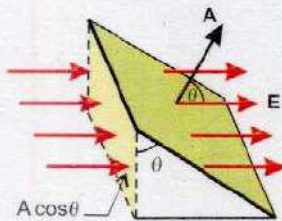


Fig.12.13 (d)

a unit area held perpendicular to field lines at a point represent the intensity  $\mathbf{E}$  of the field at that point. Suppose at a given point the value of  $\mathbf{E}$  is  $4\text{NC}^{-1}$ . This means that if  $1\text{m}^2$  area is held perpendicular to field lines at this point, 4 field lines will pass through it. In order to establish relation between electric flux  $\Phi$ , electric intensity  $\mathbf{E}$  and area  $\mathbf{A}$  we consider the Fig.12.13 (b,c,d) which shows the three dimensional representation of the electric field lines due to a uniform electric field of intensity  $\mathbf{E}$ .

In Fig.12.13 (b), area is held perpendicular to the field lines, then  $EA$  lines pass through it. The flux  $\Phi_e$  in this case is

$$\Phi_e = EA \quad \dots\dots\dots (12.10)$$

where  $A_{\perp}$  denotes that the area is held perpendicular to field lines. In Fig.12.13 (c), area  $A$  is held parallel to field lines and, as is obvious no lines cross this area, so that flux  $\Phi_e$  in this case is

$$\Phi_e = EA_{\parallel} = 0 \quad \dots\dots\dots (12.11)$$

where  $A_{\parallel}$  indicates that  $A$  is held parallel to the field lines. Fig.12.13 (d) shows the case when  $A$  is neither perpendicular nor parallel to field lines but is inclined at angle  $\theta$  with the lines. In this case we have to find the projection of the area which is perpendicular to the field lines. The area of this projection, (Fig. 12.13 d) is  $A \cos \theta$ . The flux  $\Phi$  in this case is

$$\Phi_e = EA \cos \theta$$

Usually the element of area is represented by a vector area  $\mathbf{A}$  whose magnitude is equal to the surface area  $A$  of the element and whose direction is direction of normal to the area. The electric flux  $\Phi_e$  through a patch of flat surface in terms of  $\mathbf{E}$  and  $\mathbf{A}$  is then given by

$$\Phi_e = EA \cos \theta = \mathbf{E} \cdot \mathbf{A} \quad \dots\dots\dots (12.12)$$

where  $\theta$  is the angle between the field lines and the normal to the area.

Electric flux, being a scalar product, is a scalar quantity. Its SI unit is  $\text{Nm}^2\text{C}^{-1}$ .

## 12.6 ELECTRIC FLUX THROUGH A SURFACE ENCLOSING A CHARGE

Let us calculate the electric flux through a closed surface, in shape of a sphere of radius  $r$  due to a point charge  $q$



placed at the centre of sphere as shown in Fig. 12.14. To apply the formula  $\Phi_e = \mathbf{E} \cdot \mathbf{A}$  for the computation of electric flux, the surface area of the sphere is divided into  $n$  small patches with areas of magnitudes  $\Delta A_1, \Delta A_2, \Delta A_3, \dots, \Delta A_n$ . If  $n$  is very large, each patch would be a flat element of area. The corresponding vector areas are  $\Delta \mathbf{A}_1, \Delta \mathbf{A}_2, \Delta \mathbf{A}_3, \dots, \Delta \mathbf{A}_n$  respectively. The direction of each vector area is along perpendicular drawn outward to the corresponding patch. The electric intensities at the centres of vector areas  $\Delta \mathbf{A}_1, \Delta \mathbf{A}_2, \dots, \Delta \mathbf{A}_n$  are  $\mathbf{E}_1, \mathbf{E}_2, \dots, \mathbf{E}_n$  respectively.

According to Eq.12.12, the total flux passing through the closed surface is

$$\Phi_e = \mathbf{E}_1 \cdot \Delta \mathbf{A}_1 + \mathbf{E}_2 \cdot \Delta \mathbf{A}_2 + \mathbf{E}_3 \cdot \Delta \mathbf{A}_3 + \dots + \mathbf{E}_n \cdot \Delta \mathbf{A}_n \quad \dots (12.13)$$

The direction of electric intensity and vector area is same at each patch. Moreover, because of spherical symmetry, at the surface of sphere,

$$|\mathbf{E}_1| = |\mathbf{E}_2| = |\mathbf{E}_3| = \dots = |\mathbf{E}_n| = E = \frac{1}{4\pi\epsilon_0} \frac{q}{r^2} \quad \dots (12.14)$$

$$\begin{aligned} \Phi_e &= E\Delta A_1 + E\Delta A_2 + E\Delta A_3 + \dots + E\Delta A_n \\ &= E \times (\Delta A_1 + \Delta A_2 + \Delta A_3 + \dots + \Delta A_n) \\ &= E \times (\text{total spherical surface area}) \end{aligned}$$

$$= \frac{1}{4\pi\epsilon_0} \frac{q}{r^2} \times 4\pi r^2$$

$$\Phi_e = \frac{q}{\epsilon_0} \quad \dots (12.15)$$

Now imagine that a closed surface  $S$  is enclosing this sphere. It can be seen in Fig.12.15 that the flux through the closed surface  $S$  is the same as that through the sphere. So we can conclude that total flux through a closed surface does not depend upon the shape or geometry of the closed surface. It depends upon the medium and the charge enclosed.

## 12.7 GAUSS'S LAW

Suppose point charges  $q_1, q_2, q_3, \dots, q_n$  are arbitrarily distributed in an arbitrary shaped closed surface as shown in Fig. 12.16. Using idea given in previous section, the electric flux passing through the closed surface is

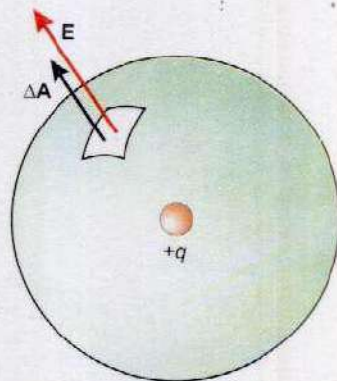


Fig. 12.14 The total electric flux through the surface of the sphere due to a charge  $q$  at its centre is  $q/\epsilon_0$ .

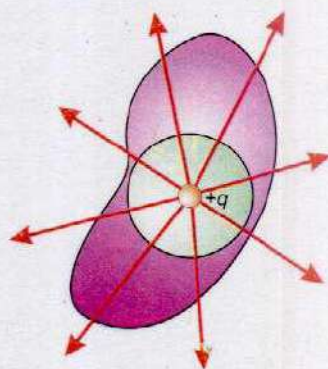


Fig. 12.15

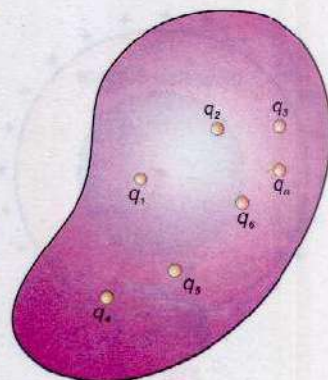


Fig. 12.16





$$\Phi_e = \frac{q_1}{\epsilon_0} + \frac{q_2}{\epsilon_0} + \frac{q_3}{\epsilon_0} + \dots + \frac{q_n}{\epsilon_0}$$

$$\Phi_e = \frac{1}{\epsilon_0} \times (q_1 + q_2 + q_3 + \dots + q_n)$$

$$\Phi_e = \frac{1}{\epsilon_0} \times (\text{total charge enclosed by closed surface})$$

$$\Phi_e = \frac{1}{\epsilon_0} \times Q \quad \dots \dots \dots (12.16)$$

where  $Q = q_1 + q_2 + q_3 + \dots + q_n$ , is the total charge enclosed by closed surface. Eq.12.16 is mathematical expression of Gauss's law which can be stated as,

**"The flux through any closed surface is  $1/\epsilon_0$  times the total charge enclosed in it".**

## 12.8 APPLICATIONS OF GAUSS'S LAW

Gauss's law is applied to calculate the electric intensity due to different charge configurations. In all such cases, an imaginary closed surface is considered which passes through the point at which the electric intensity is to be evaluated. This closed surface is known as Gaussian surface. Its choice is such that the flux through it can be easily evaluated. Next the charge enclosed by Gaussian surface is calculated and finally the electric intensity is computed by applying Gauss's law Eq.12.16. We will illustrate this procedure by considering some examples.

### (a) Intensity of Field Inside a Hollow Charged Sphere

Suppose that a hollow conducting sphere of radius  $R$  is given a positive charge  $q$ . We wish to calculate the field intensity first at a point inside the sphere.

Now imagine a sphere of radius  $R' < R$  to be inscribed within the hollow charged sphere as shown in Fig. 12.17. The surface of this sphere is the Gaussian surface. Let  $\Phi$  be flux through this closed surface. It can be seen in the figure that the charge enclosed by the Gaussian surfaces is zero. Applying Gauss's law, we have

$$\Phi_e = \frac{q}{\epsilon_0} = 0$$

Since  $\Phi_e = \mathbf{E} \cdot \mathbf{A} = 0$  as  $\mathbf{A} \neq 0$ , therefore,  $\mathbf{E} = 0$

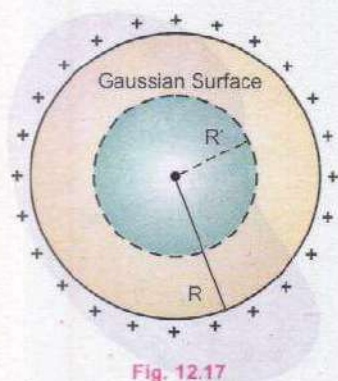
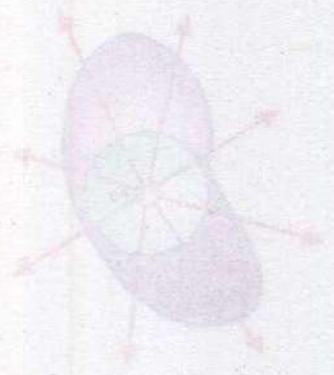


Fig. 12.17



Thus the interior of a hollow charged metal sphere is a field free region. As a consequence, any apparatus placed within a metal enclosure is "shielded" from electric fields.

### (b) Electric Intensity Due to an Infinite Sheet of Charge

Suppose we have a plane sheet of infinite extent on which positive charges are uniformly distributed. The uniform surface charge density is, say,  $\sigma$ . A finite part of this sheet is shown in Fig. 12.18. To calculate the electric intensity  $E$  at a point  $P$ , close to the sheet, imagine a closed Gaussian surface in the form of a cylinder passing through the sheet, whose one flat face contains point  $P$ . From symmetry we can conclude that  $E$  points at right angle to the end faces and away from the plane. Since  $E$  is parallel to the curved surface of the cylinder, so there is no contribution to flux from the curved wall of the cylinder. While it will be,  $EA + EA = 2EA$ , through the two flat end faces of the closed cylindrical surface, where  $A$  is the surface area of the flat faces (Fig. 12.18). As the charge enclosed by the closed surface is  $\sigma A$ , therefore, according to Gauss's law,

$$\Phi_e = \frac{1}{\epsilon_0} \times \text{charge enclosed by closed surface}$$

$$\Phi_e = \frac{1}{\epsilon_0} \times \sigma A \quad \dots \dots \dots (12.17)$$

Therefore,  $2EA = \frac{1}{\epsilon_0} \times \sigma A$

or  $E = \frac{\sigma}{2\epsilon_0} \quad \dots \dots \dots (12.18)$

In vector form,  $E = \frac{\sigma}{2\epsilon_0} \hat{r} \quad \dots \dots \dots (12.19)$

where  $\hat{r}$  is a unit vector normal to the sheet directed away from it.

### (c) Electric Intensity Between Two Oppositely Charged Parallel Plates

Suppose that two parallel and closely spaced metal plates of infinite extent separated by vacuum are given opposite charges. Under these conditions the charges are essentially concentrated on the inner surfaces of the plates. The field lines which originate on positive charges on the inner face of one plate, terminate on negative charges on the inner face of the other plate (Fig. 12.19). Thus the charges

### Do You Know?

To eliminate stray electric field interference, circuits of sensitive electronics devices such as T.V and Computers are often enclosed within metal boxes.

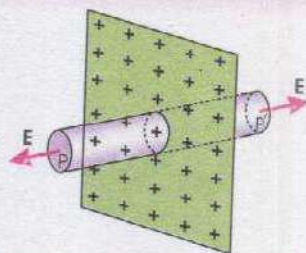
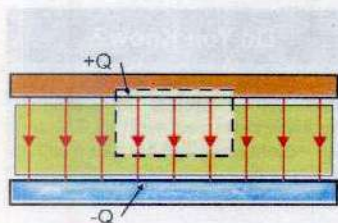


Fig. 12.18 The closed surface is in the form of a cylinder whose one face contains the point  $P$  at which electric intensity has to be determined.



Fig. 12.19 The lines of force between the plates are normal to the plates and are directed from the positive plate towards the negative one.





**Fig. 12.20** Dotted rectangle represents the cross section of Gaussian box with its top inside the upper metal plate and its bottom in the dielectric between the plates.

are uniformly distributed on the inner surface of the plate in a form of sheet of charges of surface density  $\sigma = q/A$ , where  $A$  is the area of plate and  $q$  is the amount of charge on either of the plates.

Imagine now, a Gaussian surface in the form of a hollow box with its top inside the upper metal plate and its bottom in the space between the plates as shown in Fig. 12.20. As the field lines are parallel to the sides of the box, therefore, the flux through the sides is zero. The field lines are uniformly distributed on the lower bottom face and are directed normally to it. If  $A$  is the area of this face and  $\mathbf{E}$  the electric intensity at its site, the flux through it would be  $EA$ . There is no flux through the upper end of the box because there is no field inside the metal plate. Thus the total flux  $\Phi_e$  through the Gaussian surface is  $EA$ . The charge enclosed by the Gaussian surface is  $\sigma A$ . Applying Gauss's law

$$\Phi_e = \frac{1}{\epsilon_0} \times \sigma A$$

or

$$EA = \frac{1}{\epsilon_0} \times \sigma A$$

or

$$E = \frac{\sigma}{\epsilon_0} \quad \dots\dots\dots (12.20)$$

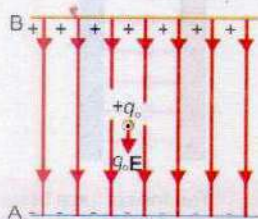
The field intensity is the same at all points between the plates. The direction of field is from positive to negative plate because a unit positive charge anywhere between the plates would be repelled from positive and attracted to negative plate and these forces are in the same direction. In vector form

$$\mathbf{E} = \frac{\sigma}{\epsilon_0} \hat{\mathbf{r}} \quad \dots\dots\dots (12.21)$$

where  $\hat{\mathbf{r}}$  is a unit vector directed from positive to negative plate.

## 12.9 ELECTRIC POTENTIAL

Let us consider a positive charge  $q$ , which is allowed to move in an electric field produced between two oppositely charged parallel plates as shown in Fig. 12.21 (a). The positive charge will move from plate B to A and will gain K.E. If it is to be moved from A to B, an external force is needed to make the charge move against the electric field and will gain P.E. Let us impose a condition that as the charge is moved from A to B, it is moved keeping electrostatic equilibrium, i.e., it moves with uniform velocity. This condition could be achieved by applying a force  $\mathbf{F}$  equal and opposite to  $q_e \mathbf{E}$  at every point along its path



**Fig. 12.21 (a)**



as shown in Fig. 12.21 (b). The work done by the external force against the electric field increases electrical potential energy of the charge that is moved.

Let  $W_{AB}$  be the work done by the force in carrying the positive charge  $q_0$  from A to B while keeping the charge in equilibrium. The change in its potential energy  $\Delta U = W_{AB}$

$$\text{or} \quad U_B - U_A = W_{AB} \quad \dots\dots\dots (12.22)$$

where  $U_A$  and  $U_B$ , are defined to be the potential energies at points A and B, respectively.

To describe electric field we introduce the idea of electric potential difference. The potential difference between two points A and B in an electric field is defined as the work done in carrying a unit positive charge from A to B while keeping the charge in equilibrium, that is,

$$\Delta V = V_B - V_A = \frac{W_{AB}}{q_0} = \frac{\Delta U}{q_0} \quad \dots\dots\dots (12.23)$$

where  $V_A$  and  $V_B$  are defined electric potentials at point A and B respectively. Electric potential energy difference and electric potential difference between the points A and B are related as

$$\Delta U = q_0 \Delta V = W_{AB} \quad \dots\dots\dots (12.24)$$

Thus the potential difference between the two points can be defined as the difference of the potential energy per unit charge.

As the unit of P.E. is joule, Eq.12.23 shows that the unit of potential difference is joule per coulomb. It is called volt such that,

$$1 \text{ volt} = \frac{1 \text{ joule}}{1 \text{ coulomb}} \quad \dots\dots\dots (12.25)$$

That is, a potential difference of 1 volt exists between two points if work done in moving a unit positive charge from one point to other, keeping equilibrium, is one joule.

In order to give a concept of electric potential at a point in an electric field, we must have a reference to which we assign zero electric potential. This point is usually taken at infinity. Thus in Eq. 12.23, if we take A to be at infinity and choose  $V_A=0$ , the electric potential at B will be  $V_B = W_{\infty B} / q_0$  or dropping the subscripts.

$$V = \frac{W}{q_0} \quad \dots\dots\dots (12.26)$$

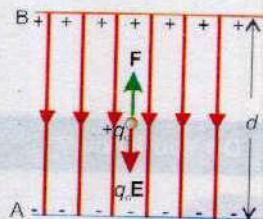


Fig. 12.21 (b)

Do You Know?

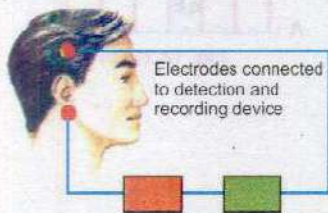


An ECG records the "voltage" between points on human skin generated by electrical process in the heart. This ECG is made in running position providing information about the heart's performance under stress.

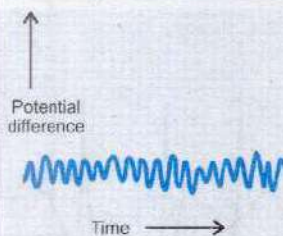




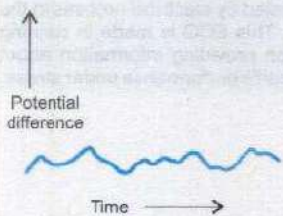
## Do You Know?



### EEG (Normal alpha rhythm)



### EEG (Abnormal)



In electroencephalography the potential differences created by the electrical activity of the brain are used for diagnosing abnormal behaviour.

which states that the electric potential at any point in an electric field is equal to work done in bringing a unit positive charge from infinity to that point keeping it in equilibrium. It is to be noted that potential at a point is still potential difference between the potential at that point and potential at infinity. Both potential and potential differences are scalar quantities because both  $W$  and  $q_0$  are scalars.

## Electric Field as Potential Gradient

In this section we will establish a relation between electric intensity and potential difference. As a special case, let us consider the situation shown in Fig. 12.21 (b). The electric field between the two charged plates is uniform, let its value be  $E$ . The potential difference between A and B is given by the equation

$$V_B - V_A = \frac{W_{AB}}{q_0} \quad \dots\dots\dots (12.27)$$

where  $W_{AB} = Fd = -q_0Ed$  (the negative sign is needed because  $F$  must be applied opposite to  $q_0E$  so as to keep it in equilibrium). With this, Eq. 12.27 becomes

$$V_B - V_A = -\frac{q_0Ed}{q_0} = -Ed$$

or 
$$E = -\frac{(V_B - V_A)}{d} = -\frac{\Delta V}{d} \quad \dots\dots\dots (12.28)$$

If the plates A & B are separated by infinitesimally small distance  $\Delta r$ , the Eq. 12.28 is modified as

$$E = -\frac{\Delta V}{\Delta r} \quad \dots\dots\dots (12.29)$$

The quantity  $\frac{\Delta V}{\Delta r}$  gives the maximum value of the rate of change of potential with distance because the charge has been moved along a field line along which the distance  $\Delta r$  between the two plates is minimum. It is known as potential gradient. Thus the electric intensity is equal to the negative of the gradient of potential. The negative sign indicates that the direction of  $E$  is along the decreasing potential.

The unit of electric intensity from Eq. 12.29 is volt/metre which is equal to  $\text{NC}^{-1}$  as shown below:

$$1 \frac{\text{volt}}{\text{metre}} = 1 \frac{\text{joule/coulomb}}{\text{metre}} = 1 \frac{\text{newton} \times \text{metre}}{\text{metre} \times \text{coulomb}} = 1 \frac{\text{newton}}{\text{coulomb}}$$



## Electric Potential at a Point due to a Point Charge

Let us derive an expression for the potential at a certain point in the field of a positive point charge  $q$ . This can be accomplished by bringing a unit positive charge from infinity to that point keeping the charge in equilibrium. The target can be achieved using Eq. 12.29 in the form  $\Delta V = -E \Delta r$ , provided electric intensity  $E$  remains constant. However in this case  $E$  varies inversely as square of distance from the point charge, it no more remains constant so we use basic principles to compute the electric potential at a point. The field is radial as shown in Fig. 12.22.

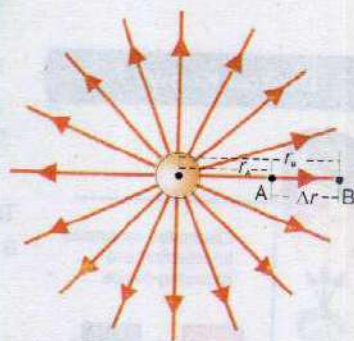


Fig. 12.22

Let us take two points A and B, infinitesimally close to each other, so that  $E$  remains almost constant between them. The distance of points A and B from  $q$  are  $r_A$  and  $r_B$  respectively and distance of midpoint of space interval between A and B is  $r$  from  $q$ . Then according to Fig. 12.22,

$$r_B = r_A + \Delta r \quad \dots\dots\dots (12.30)$$

$$\Delta r = r_B - r_A \quad \dots\dots\dots (12.31)$$

As  $r$  represents mid point of interval between A and B so

$$r = \frac{r_A + r_B}{2} \quad \dots\dots\dots (12.32)$$

The magnitude of electric intensity at this point is,

$$E = \frac{1}{4\pi\epsilon_0} \frac{q}{r^2} \quad \dots\dots\dots (12.33)$$

As the points A and B are very close then, as a first approximation, we can take the arithmetic mean to be equal to geometric mean which gives

$$\frac{r}{r_A} = \frac{r_B}{r}$$

Therefore,  $r^2 = r_A r_B \quad \dots\dots\dots (12.34)$

Thus, Eq. 12.33 can be written as

$$E = \frac{1}{4\pi\epsilon_0} \frac{q}{r_A r_B} \quad \dots\dots\dots (12.35)$$

Now, if a unit positive charge is moved from B to A, the work done is equal to the potential difference between A and B,

$$V_A - V_B = -E(r_A - r_B)$$

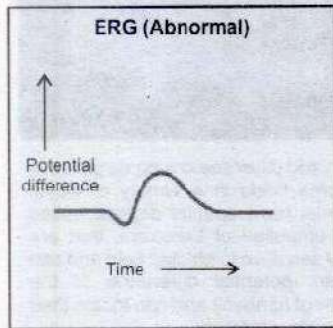
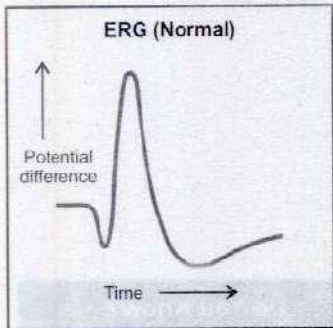
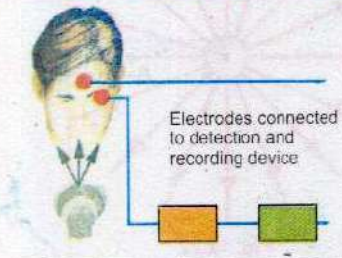
### Do You Know?



Fish and other sea creatures produce electric fields in a variety of ways. Sharks have special organs, called the ampullae of Lorenzini, that are very sensitive to electric field and can detect potential difference of the order of nanovolt and can locate their prey very precisely.



**Do You Know?**



The electrical activity of the retina of the eye generates the potential differences used in electroretinography.

$$V_A - V_B = E(r_B - r_A) \quad \dots\dots\dots (12.36)$$

Substituting value of  $E$  from Eq.12.35,

$$V_A - V_B = \frac{q}{4\pi\epsilon_0} \left( \frac{r_B - r_A}{r_A r_B} \right) \quad \dots\dots\dots (12.37)$$

$$V_A - V_B = \frac{q}{4\pi\epsilon_0} \left( \frac{1}{r_A} - \frac{1}{r_B} \right) \quad \dots\dots\dots (12.38)$$

To calculate absolute potential or potential at A, point B is assumed to be infinity point so that  $V_B = 0$  and hence

$$\frac{1}{r_B} = \frac{1}{r_\infty} = \frac{1}{\infty} = 0$$

This gives,  $V_A = \frac{1}{4\pi\epsilon_0} \frac{q}{r_A} \quad \dots\dots\dots (12.39)$

The general expression for electric potential  $V_r$  at a distance  $r$  from  $q$  is,

$$V_r = \frac{1}{4\pi\epsilon_0} \frac{q}{r} \quad \dots\dots\dots (12.40)$$

**Example 12.3:** Two opposite point charges, each of magnitude  $q$  are separated by a distance  $2d$ . What is the electric potential at a point P mid-way between them?

**Solution:**

$$V^+ = \frac{1}{4\pi\epsilon_0} \frac{q}{d} \quad \& \quad V^- = - \frac{1}{4\pi\epsilon_0} \frac{q}{d}$$

$$V = V^+ + V^- = \frac{1}{4\pi\epsilon_0} \frac{q}{d} - \frac{1}{4\pi\epsilon_0} \frac{q}{d} = 0$$

So potential at P due to opposite charges is zero.

**12.10 ELECTRON VOLT**

Referring Fig. 12.21, we know that when a particle of charge  $q$  moves from point A with potential  $V_A$  to a point B with potential  $V_B$ , keeping electrostatic equilibrium, the change in potential energy  $\Delta U$  of particle is,

$$\Delta U = q(V_B - V_A) = q\Delta V \quad \dots\dots\dots (12.41)$$

If no external force acts on the charge to maintain equilibrium, this change in P.E. appears in the form of change in K.E. Suppose charge carried by the particle is  $q = e = 1.6 \times 10^{-19}$  C.



Thus, in this case, the energy acquired by the charge will be

$$\Delta K.E = q \Delta V = e \Delta V = (1.6 \times 10^{-19} \text{ C})(\Delta V)$$

Moreover, assume that  $\Delta V = 1$  volt, hence

$$\Delta K.E = q \Delta V = (1.6 \times 10^{-19} \text{ C}) \times (1 \text{ volt})$$

$$\Delta K.E = (1.6 \times 10^{-19}) \times (\text{C} \times \text{V}) = 1.6 \times 10^{-19} \text{ J}$$

The amount of energy equal to  $1.6 \times 10^{-19} \text{ J}$  is called one electron-volt and is denoted by  $1 \text{ eV}$ . It is defined as "the amount of energy acquired or lost by an electron as it traverses a potential difference of one volt". Thus,

$$1 \text{ eV} = 1.6 \times 10^{-19} \text{ J} \quad \dots\dots\dots (12.42)$$

**Example 12.4:** A particle carrying a charge of  $2e$  falls through a potential difference of  $3.0 \text{ V}$ . Calculate the energy acquired by it.

**Solution:**  $q = 2e$  ,  $\Delta V = 3.0 \text{ V}$

The energy acquired by the particle is

$$\begin{aligned} \Delta K.E &= q \Delta V = (2e)(3.0 \text{ V}) = 6.0 \text{ eV} \\ &= 6.0 \times 1.6 \times 10^{-19} \text{ J} = 9.6 \times 10^{-19} \text{ J} \end{aligned}$$

## 12.11 ELECTRIC AND GRAVITATIONAL FORCES (A COMPARISON)

In chapter 4, we pointed out that gravitational force is a conservative force, that is, work done in such a field is independent of path. It can also be proved that Coulomb's electrostatic force is also conservative force. The electric force between two charges  $F = \frac{q_1 q_2}{4\pi\epsilon_0 r^2}$ , is similar in form to the gravitational force between the two point masses,  $F = G \frac{m_1 m_2}{r^2}$ . Both forces vary inversely with the square of the distance between the two charges or the two masses. However, the value of gravitational constant  $G$  is very small as compared to electrical constant  $\frac{1}{4\pi\epsilon_0}$ . It is because of this fact that the gravitational force is a very weak force as compared to electrostatic force. As regards their qualitative aspect, the electrostatic force could be attractive or repulsive while, on the other hand, gravitational force is only attractive. Another difference to be noted is that the electrostatic force is medium dependant and can be shielded while gravitational





force lacks this property.

## 12.12 CHARGE ON AN ELECTRON BY MILLIKAN'S METHOD

In 1909, R.A Millikan devised a technique that resulted in precise measurement of the charge on an electron.

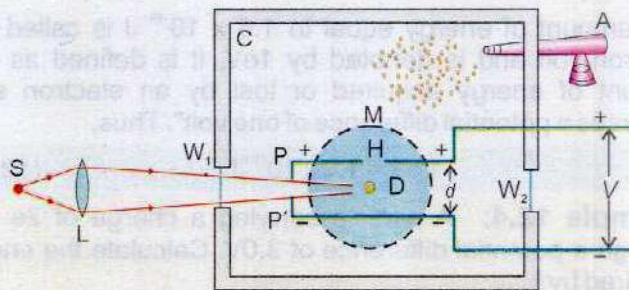


Fig. 12.23 (a)

A schematic diagram of the Millikan oil drop experiment is shown in Fig. 12.23 (a). Two parallel plates  $PP'$  are placed inside a container  $C$ , to avoid disturbances due to air currents. The separation between the plates is  $d$ . The upper plate  $P$  has a small hole  $H$ , as shown in the figure. A voltage  $V$  is applied to the plates due to which the electric field  $E$  is setup between the plates. The magnitude of its value is  $E = V/d$ . An atomizer  $A$  is used for spraying oil drops into the container through a nozzle. The oil drop gets charged because of friction between walls of atomizer and oil drops. These oil drops are very small, and are actually in the form of mist. Some of these drops happen to pass through the hole in the upper plate. The space between the plates is illuminated by the light coming from the source  $S$  through the lens  $L$  and window  $W_1$ . The path of motion of these drops can be carefully observed by a microscope  $M$ .



Fig. 12.23 (b) Oil drop balanced by the gravitational force and the Coulomb force.

A given droplet between the two plates could be suspended in air if the gravitational force  $F_g = mg$  acting on the drop is equal to the electrical force  $F_e = qE$ , as shown in Fig. 12.23(b). The  $F_e$  can be adjusted equal to  $F_g$  by adjusting the voltage. In this case, we can write,

$$F_e = F_g \quad \dots \dots \dots (12.43)$$

or  $qE = mg$

If  $V$  is the value of p. d. between the plates for this setting, then



$$E = \frac{V}{d}, \quad \text{we may write} \quad q \frac{V}{d} = mg$$

$$q = \frac{mgd}{V} \quad \dots\dots\dots (12.44)$$

In order to determine the mass  $m$  of the droplet, the electric field between the plates is switched off. The droplet falls under the action of gravity through air. It attains terminal speed  $v_t$  almost at the instant the electric field is switched off. Its terminal speed  $v_t$  is determined by timing the fall of the droplet over a measured distance. Since the drag force  $F$  due to air acting upon the droplet when it is falling with constant terminal speed is equal to its weight. Hence, using Stokes's law

$$F = 6\pi\eta r v_t = mg$$

where  $r$  is the radius of the droplet and  $\eta$  is the coefficient of viscosity for air. If  $\rho$  is the density of the droplet, then

$$m = \frac{4}{3} \pi r^3 \rho \quad \dots\dots\dots (12.45)$$

Hence, 
$$\frac{4}{3} \pi r^3 \rho g = 6 \pi \eta r v_t$$

or 
$$r^2 = \frac{9 \eta v_t}{2 \rho g}$$

Knowing the value of  $r$ , the mass  $m$  can be calculated by using Eq. (12.45). This value of  $m$  is substituted in Eq. 12.44 to get the value of charge  $q$  on the droplet.

Millikan measured the charge on many drops and found that each charge was an integral multiple of a minimum value of charge equal to  $1.6 \times 10^{-19}$  C. He, therefore, concluded that this minimum value of the charge is the charge on an electron.

**Example 12.5:** In Millikan oil drop experiment, an oil drop of mass  $4.9 \times 10^{-15}$  kg is balanced and held stationary by the electric field between two parallel plates. If the potential difference between the plates is 750 V and the spacing between them is 5.0 mm, calculate the charge on the droplet. Assume  $g = 9.8 \text{ ms}^{-2}$ .

**Solution:**

Mass of drop =  $m = 4.9 \times 10^{-15}$  kg

Potential difference =  $V = 750$  V

Spacing between plates =  $d = 5.0 \text{ mm} = 5.0 \times 10^{-3} \text{ m}$



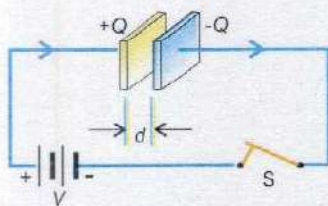


Fig. 12.24

For the droplet of the charge  $q$ , we have

$$q = \frac{mgd}{V} = \frac{4.9 \times 10^{-15} \text{ kg} \times 9.8 \text{ ms}^{-2} \times 5.0 \times 10^{-3} \text{ m}}{750 \text{ V}}$$

$$q = 3.2 \times 10^{-19} \text{ C}$$

## 12.13 CAPACITOR

A capacitor is a device that can store charge. It consists of two conductors placed near one another separated by vacuum, air or any other insulator, known as dielectric. Usually the conductors are in the form of parallel plates, and the capacitor is known as parallel plate capacitor. When the plates of such a capacitor are connected to a battery of voltage  $V$  (Fig. 12.24), it establishes a potential difference of  $V$  volts between the two plates and the battery places a charge  $+Q$  on the plate connected with its positive terminal and a charge  $-Q$  on the other plate, connected to its negative terminal. Let  $Q$  be the magnitude of the charge on either of the plates. It is found that

$$Q \propto V \quad \text{or} \quad Q = CV \quad \text{or} \quad C = \frac{Q}{V} \quad \dots\dots (12.46)$$

The proportionality constant  $C$  is called the capacitance of the capacitor. As we shall see later, it depends upon the geometry of the plates and the medium between them. It is a measure of the ability of capacitor to store charge. The capacitance of a capacitor can be defined as the amount of charge on one plate necessary to raise the potential of that plate by one volt with respect to the other. The SI unit of capacitance is coulomb per volt, which because of its frequent use, is commonly called farad (F), after the famous English scientist Faraday.

### For Your Information

One farad is an enormous amount of capacitance. For practical purposes its sub-multiple units are used which are given below,

- 1 micro-farad =  $1 \mu\text{F} = 10^{-6}$  farad
- 1 pico-farad =  $1 \text{ pF} = 10^{-12}$  farad

**"The capacitance of a capacitor is one farad if a charge of one coulomb, given to one of the plates of a parallel plate capacitor, produces a potential difference of one volt between them".**

## 12.14 CAPACITANCE OF A PARALLEL PLATE CAPACITOR

Consider a parallel plate capacitor consisting of two plane metal plates, each of area  $A$ , separated by a distance  $d$  as shown in Fig. 12.24. The distance  $d$  is small so that the electric field  $E$  between the plates is uniform and confined



almost entirely in the region between the plates. Let initially the medium between the plates be air or vacuum. Then according to Eq. 12.46,

$$C_{vac} = \frac{Q}{V} \quad \dots\dots\dots (12.47)$$

where  $Q$  is the charge on the capacitor and  $V$  is the potential difference between the parallel plates. The magnitude  $E$  of electric intensity is related with the distance  $d$  by Eq. 12.28 as

$$E = \frac{V}{d} \quad \dots\dots\dots (12.48)$$

As  $Q$  is the charge on either of the plates of area  $A$ , the surface density of charge on the plates is as

$$\sigma = \frac{Q}{A}$$

As already shown in section 12.8, the electric intensity between two oppositely charged plates is given by  $E = \frac{\sigma}{\epsilon_0}$

Substituting the value of  $\sigma$ , we have

$$\frac{V}{d} = \frac{Q}{A\epsilon_0} \quad \dots\dots\dots (12.49)$$

It gives

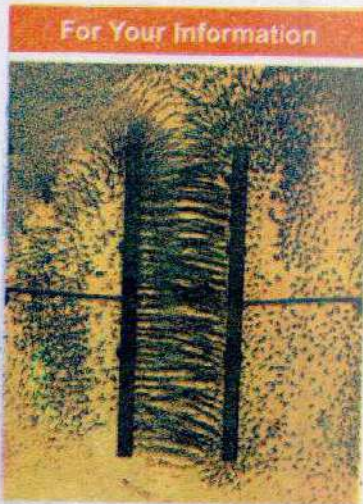
$$C_{vac} = \frac{Q}{V} = \frac{A\epsilon_0}{d} \quad \dots\dots\dots (12.50)$$

If an insulating material, called dielectric, of relative permittivity  $\epsilon_r$  is introduced between the plates, the capacitance of capacitor is enhanced by the factor  $\epsilon_r$ . Capacitors commonly have some dielectric medium, thereby  $\epsilon_r$  is also called as dielectric constant.

Following experiment gives the effect of insertion of dielectric between the plates of a capacitor.

Consider a charged capacitor whose plates are connected to a voltmeter (Fig. 12.25 a). The deflection of the meter is a measure of the potential difference between the plates. When a dielectric material is inserted between the plates, reading drops indicating a decrease in the potential difference between the plates (Fig. 12.25 b). From the definition,  $C = Q/V$ , since  $V$  decreases while  $Q$  remains constant, the value of  $C$  increases. Then Eq. 12.50 becomes,

$$C_{med} = \frac{A\epsilon_0\epsilon_r}{d} \quad \dots\dots\dots (12.51)$$



The electric field lines between the plates of a parallel-plate capacitor. Small bits of thread are suspended in oil and become aligned with the electric field. Note that the lines are equally spaced, indicating that the electric field there is uniform.

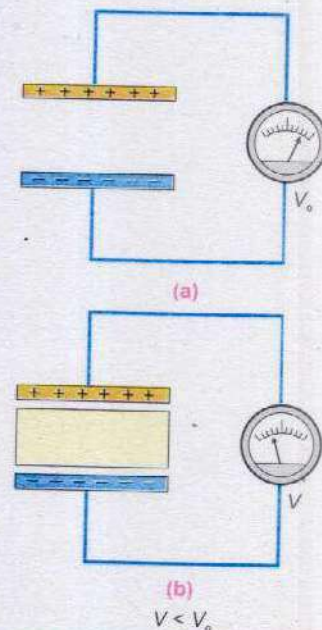


Fig. 12.25 Effect of a dielectric on the capacitance of a capacitor.



Eq.12.50 shows the dependence of a capacitor upon the area of plates, the separation between the plates and medium between them.

Dividing Eq.12.51 by Eq.12.50 we get expression for dielectric constant as,

$$\epsilon_r = \frac{C_{med}}{C_{vac}} \dots\dots\dots (12.52)$$

From Eq.12.52 dielectric co-efficient or dielectric constant is defined as

**“The ratio of the capacitance of a parallel plate capacitor with an insulating substance as medium between the plates to its capacitance with vacuum (or air) as medium between them”.**

**For Your Information**



A collection of capacitors used in various appliances.

**12.15 ELECTRIC POLARIZATION OF DIELECTRICS**

The increase in the capacity of a capacitor due to presence of dielectric is due to electric polarization of dielectric.

The dielectric consists of atoms and molecules which are electrically neutral on the average, i.e, they contain equal amounts of negative and positive charges. The distribution of these charges in the atoms and molecules is such that the centre of the positive charge coincides with the centre of negative charge. When the molecules of dielectric are subjected to an electric field between the plates of a capacitor, the negative charges (electrons) are attracted towards the positively charged plate of the capacitor and the positive charges (nuclei) towards the negatively charged plate. The electrons in the dielectric (insulator) are not free to move but it is possible that the electrons and nuclei can undergo slight displacement when subjected to an electric field. As a result of this displacement the centre of positive and negative charges now no longer coincide with each other and one end of molecules shows a negative charge and the other end, an equal amount of positive charge but the molecule as a whole is still neutral. Two equal and opposite charges separated by a small distance are said to constitute a dipole. Thus the molecules of the dielectric under the action of electric field become dipoles and the dielectric is said to be polarized.

The effect of the polarization of dielectric is shown in

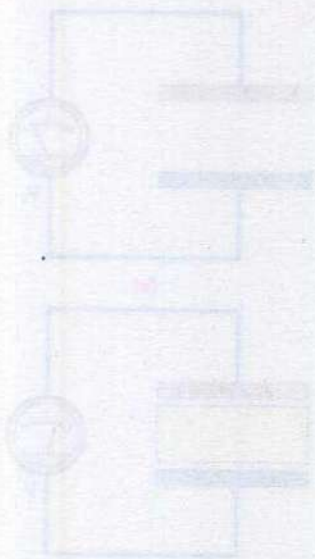




Fig. 12.26. The positively charged plate attracts the negative end of the molecular dipoles and the negatively charged plate attracts the positive end. Thus the surface of the dielectric which is in contact with the positively charged plate places a layer of negative charges on the plate. Similarly the surface of the dielectric in contact with the negatively charged plate places a layer of positive charges. It effectively decreases the surface density of the charge  $\sigma$  on the plates. As the electric intensity  $E$  between the plates is  $\frac{\sigma}{\epsilon_0}$ , so  $E$  decreases due to

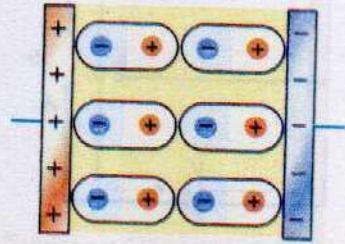


Fig. 12.26

polarization of the dielectric. This results into a decrease of potential difference between the plates due to presence of dielectric as demonstrated by the experiment described in the previous section.

## 12.16 ENERGY STORED IN A CAPACITOR

A capacitor is a device to store charge. Alternatively, it is possible to think of a capacitor as a device for storing electrical energy. After all, the charge on the plate possesses electrical potential energy which arises because work is to be done to deposit charge on the plates. This is due to the fact that with each small increment of charge being deposited during the charging process, the potential difference between the plates increases, and a larger amount of work is needed to bring up next increment of charge.

Initially when the capacitor is uncharged, the potential difference between plates is zero and finally it becomes  $V$  when  $q$  charge is deposited on each plate. Thus, the average

potential difference is  $\frac{0 + V}{2} = \frac{1}{2}V$

Therefore P.E. = Energy =  $\frac{1}{2} q V$

Using the relation  $q = CV$  for capacitor we get

$$\text{Energy} = \frac{1}{2} CV^2 \quad \dots \dots \dots (12.53)$$

It is also possible to regard the energy as being stored in electric field between the plates, rather than the potential energy of the charges on the plates. Such a view point is useful when electric field strength between the plates instead of charges on the plates causing field is to be considered.

This relation can be obtained by substituting  $V = Ed$  and  $C = A\epsilon_0\epsilon_r/d$  in Eq.12.53,



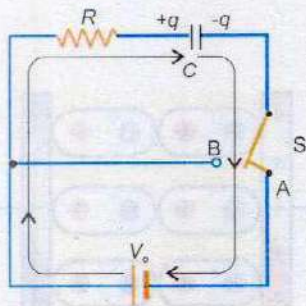


Fig. 12.27 Charging a capacitor

$$\begin{aligned} \text{Energy} &= \frac{1}{2} \left( \frac{A\epsilon_r\epsilon_0}{d} \right) (Ed)^2 \\ &= \frac{1}{2} \epsilon_r\epsilon_0 E^2 \times (Ad) \end{aligned}$$

As  $(Ad)$  is volume between the plates so

$$\text{Energy density} = \frac{\text{Energy}}{\text{Volume}} = \frac{1}{2} \epsilon_r\epsilon_0 E^2 \quad \dots\dots (12.54)$$

This equation is valid for any electric field strength.

## 12.17 CHARGING AND DISCHARGING A CAPACITOR

Many electric circuits consist of both capacitors and resistors. Fig.12.27 shows a resistor-capacitor circuit called R-C-circuit. When the switch S is set at terminal A, the R-C combination is connected to a battery of voltage  $V_0$  which starts charging the capacitor through the resistor R.

The capacitor is not charged immediately, rather charges build up gradually to the equilibrium value of  $q_0 = CV_0$ . The growth of charge with time for different resistances is shown in Fig.12.28. According to this graph  $q = 0$  at  $t = 0$  and increases gradually with time till it reaches its equilibrium value  $q_0 = CV_0$ . The voltage  $V$  across capacitor at any instant can be obtained by dividing  $q$  by  $C$ , as  $V = q/C$ .

How fast or how slow the capacitor is charging or discharging, depends upon the product of the resistance  $R$  and the capacitance  $C$  used in the circuit. As the unit of product  $RC$  is that of time, so this product is known as time constant and is defined as the time required by the capacitor to deposit 0.63 times the equilibrium charge  $q_0$ . The graphs of Fig.12.28 show that the charge reaches its equilibrium value sooner when the time constant is small.

Fig. 12.29(a) illustrates the discharging of a capacitor through a resistor. In this figure, the switch S is set at point B, so the charge  $+q$  on the left plate can flow anti-clockwise through the resistance and neutralize the charge  $-q$  on the right plate.

The graphs in Fig. 12.29(b) shows that discharging begins at  $t = 0$  when  $q = CV_0$  and decreases gradually to zero. Smaller values of time constant  $RC$  lead to a more rapid discharge.

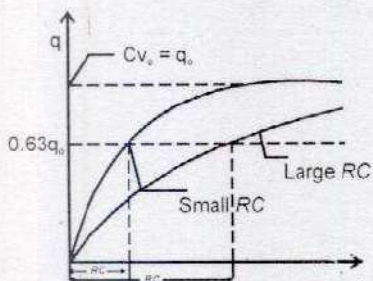
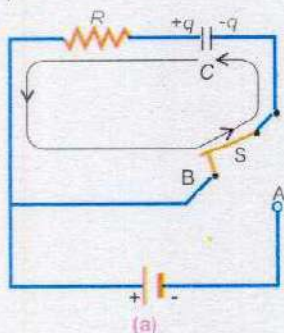
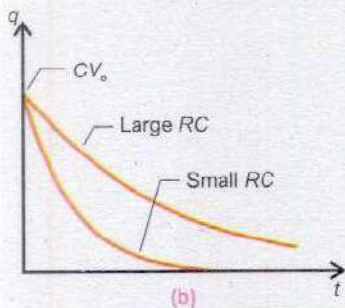


Fig. 12.28



(a)



(b)

Fig. 12.29 Discharging a capacitor



**Example 12.6:** The time constant of a series RC circuit is  $t = RC$ . Verify that an ohm times farad is equivalent to second.

**Solution:** Ohm's law in terms of potential difference  $V$ , current  $I$  and resistance  $R$  can be written as,

$$V = IR$$

Putting  $I = q/t$ , this equation transforms into the equation,

$$V = \frac{q}{t} R$$

or

$$R = \frac{V \times t}{q}$$

According to equation  $q = CV$ ,  $C = q/V$

Multiplying this equation with above equation gives,

$$RC = \frac{V \times t}{q} \times \frac{q}{V} = t$$

Hence  $1 \text{ ohm} \times 1 \text{ farad} = 1 \text{ second}$

where ohm is the unit of resistance  $R$ .

### Interesting Application

The charging/discharging of a capacitor enables some windshield wipers of cars to be used intermittently during a light drizzle. In this mode of operation the wipers remain off for a while and then turn on briefly. The timing of the on-off cycle is determined by the time constant of a resistor-capacitor combination.

### SUMMARY

- The Coulomb's law states that the force between two point charges is directly proportional to the product of the magnitudes of charges and inversely proportional to the square of the distance between them.
- Electric field force per unit charge at a point is called electric field strength or electric field intensity at that point.
- The number of the field lines passing through a certain element of area is known as electric flux through that area, denoted by  $\Phi$ .
- The electric flux  $\Phi$  through a vector area  $\mathbf{A}$ , in the electric field of intensity  $\mathbf{E}$  is given by  $\Phi = \mathbf{E} \cdot \mathbf{A} = EA \cos\theta$ , where  $\theta$  is the angle between the field lines and the normal to surface area.
- Gauss's law is stated as "the flux through any closed surface is  $1/\epsilon_0$  times the total charge enclosed in it.
- The interior of a hollow charged metal sphere is a field free region.
- The electric intensity between two oppositely charged parallel plates is  $E = \frac{\sigma}{\epsilon_0}$ .
- The amount of work done in bringing a unit positive charge from infinity to a point against electric field is the electric potential at that point.



- Capacitance of a capacitor is a measure of the ability of a capacitor to store charge.
- The capacitance of a parallel plate capacitor is  $C_{vac} = \frac{Q}{V} = \frac{A\epsilon_0}{d}$ .
- The increase in the capacitance of a capacitor due to presence of dielectric is due to electric polarization of the dielectric.

## QUESTIONS

- 12.1 The potential is constant throughout a given region of space. Is the electrical field zero or non-zero in this region? Explain.
- 12.2 Suppose that you follow an electric field line due to a positive point charge. Do electric field and the potential increase or decrease?
- 12.3 How can you identify that which plate of a capacitor is positively charged?
- 12.4 Describe the force or forces on a positive point charge when placed between parallel plates
- (a) with similar and equal charges (b) with opposite and equal charges
- 12.5 Electric lines of force never cross. Why?
- 12.6 If a point charge  $q$  of mass  $m$  is released in a non-uniform electric field with field lines pointing in the same direction, will it make a rectilinear motion?
- 12.7 Is  $E$  necessarily zero inside a charged rubber balloon if balloon is spherical? Assume that charge is distributed uniformly over the surface.
- 12.8 Is it true that Gauss's law states that the total number of lines of forces crossing any closed surface in the outward direction is proportional to the net positive charge enclosed within surface?
- 12.9 Do electrons tend to go to region of high potential or of low potential?

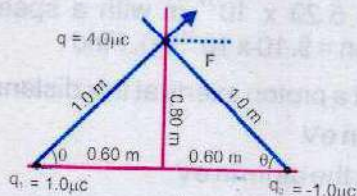
## PROBLEMS

- 12.1 Compare magnitudes of electrical and gravitational forces exerted on an object (mass = 10.0 g, charge = 20.0  $\mu\text{C}$ ) by an identical object that is placed 10.0 cm from the first. ( $G = 6.67 \times 10^{-11} \text{Nm}^2 \text{kg}^{-2}$ )

$$(\text{Ans: } \frac{F_e}{F_g} = 5.4 \times 10^{14})$$



- 12.2 Calculate vectorially the net electrostatic force on  $q$  as shown in the figure.



(Ans:  $F = 0.04 \hat{i} \text{ N}$ )

- 12.3 A point charge  $q = -8.0 \times 10^{-8} \text{ C}$  is placed at the origin. Calculate electric field at a point 2.0 m from the origin on the z-axis.  
[Ans:  $(-1.8 \times 10^2 \hat{k}) \text{ NC}^{-1}$ ]
- 12.4 Determine the electric field at the position  $\mathbf{r} = (4 \hat{i} + 3 \hat{j}) \text{ m}$  caused by a point charge  $q = 5.0 \times 10^{-6} \text{ C}$  placed at origin.  
[Ans:  $(1440 \hat{i} + 1080 \hat{j}) \text{ N C}^{-1}$ ]
- 12.5 Two point charges,  $q_1 = -1.0 \times 10^{-6} \text{ C}$  and  $q_2 = +4.0 \times 10^{-6} \text{ C}$ , are separated by a distance of 3.0 m. Find and justify the zero-field location. (Ans: 3.0 m)
- 12.6 Find the electric field strength required to hold suspended a particle of mass  $1.0 \times 10^{-6} \text{ kg}$  and charge  $1.0 \mu\text{C}$  between two plates 10.0 cm apart. (Ans:  $9.8 \text{ Vm}^{-1}$ )
- 12.7 A particle having a charge of 20 electrons on it falls through a potential difference of 100 volts. Calculate the energy acquired by it in electron volts (eV). [Ans:  $(2.0 \times 10^3 \text{ eV})$ ]
- 12.8 In Millikan's experiment, oil droplets are introduced into the space between two flat horizontal plates, 5.00 mm apart. The plate voltage is adjusted to exactly 780V so that the droplet is held stationary. The plate voltage is switched off and the selected droplet is observed to fall a measured distance of 1.50 mm in 11.2 s. Given that the density of the oil used is  $900 \text{ kg m}^{-3}$ , and the viscosity of air at laboratory temperature is  $1.80 \times 10^{-5} \text{ Nm}^{-2}\text{s}$ , calculate
- a) The mass, and b) The charge on the droplet (Assume  $g = 9.8 \text{ ms}^{-2}$ )  
[Ans: (a)  $5.14 \times 10^{-16} \text{ kg}$ , (b)  $3.20 \times 10^{-19} \text{ C}$ ]
- 12.9 A proton placed in a uniform electric field of  $5000 \text{ NC}^{-1}$  directed to right is allowed to go a distance of 10.0 cm from A to B. Calculate
- (a) Potential difference between the two points  
(b) Work done by the field  
(c) The change in P.E. of proton  
(d) The change in K.E. of the proton  
(e) Its velocity (mass of proton is  $1.67 \times 10^{-27} \text{ kg}$ )  
(Ans: -500 V, 500 eV, -500 eV, 500 eV,  $3.097 \times 10^5 \text{ ms}^{-1}$ )
- 12.10 Using zero reference point at infinity, determine the amount by which a point charge of  $4.0 \times 10^{-6} \text{ C}$  alters the electric potential at a point 1.2 m away, when
- (a) Charge is positive b) Charge is negative  
(Ans:  $+3.0 \times 10^2 \text{ V}$ ,  $-3.0 \times 10^2 \text{ V}$ )



12.11 In Bohr's atomic model of hydrogen atom, the electron is in an orbit around the nuclear proton at a distance of  $5.29 \times 10^{-11}$  m with a speed of  $2.18 \times 10^6$  ms<sup>-1</sup>. ( $e = 1.60 \times 10^{-19}$  C, mass of electron =  $9.10 \times 10^{-31}$  kg). Find

- (a) The electric potential that a proton exerts at this distance
- (b) Total energy of the atom in eV
- (c) The ionization energy for the atom in eV

(Ans: +27.20 V, -13.6 eV, +13.60 eV)

12.12 The electronic flash attachment for a camera contains a capacitor for storing the energy used to produce the flash. In one such unit, the potential difference between the plates of a 750  $\mu$ F capacitor is 330 V. Determine the energy that is used to produce the flash.

(Ans: 40.8 J)

12.13 A capacitor has a capacitance of  $2.5 \times 10^{-8}$  F. In the charging process, electrons are removed from one plate and placed on the other one. When the potential difference between the plates is 450 V, how many electrons have been transferred? ( $e = 1.60 \times 10^{-19}$  C)

(Ans:  $7.0 \times 10^{13}$  electrons)



# Chapter 13

## CURRENT ELECTRICITY

### Learning Objectives

At the end of this chapter the students will be able to:

1. Understand the concept of steady current.
2. Describe some sources of current.
3. Recognize effects of current.
4. Understand and describe Ohm's law.
5. Sketch and explain the current-voltage characteristics of a metallic conductor at constant temperature, diode and filament lamp.
6. Understand resistivity and explain its dependence upon temperature.
7. Understand and elaborate conductance and conductivity of conductor.
8. Solve problems relating the variation of resistance with temperature for one dimension current flow.
9. Know the value of resistance by reading colour code on it.
10. Know the working and use of rheostat in the potential divider circuit.
11. Describe the characteristics of thermistor.
12. Use the energy considerations to distinguish between emf and p.d.
13. Understand the internal resistance of sources and its consequences for external circuits.
14. Describe the conditions for maximum power transfer.
15. Know and use the application of Kirchhoff's first law as conservation of charge.
16. Know and use the application of Kirchhoff's second law as conservation of energy.
17. Describe the function of Wheatstone Bridge to measure the unknown resistance.
18. Describe the function of potentiometer to measure and compare potentials without drawing any current from the circuit.

**M**ost practical applications of electricity involve charges in motion or the electric current. A light bulb glows due to the flow of electric current. The current that flows through the coil of a motor causes its shaft to rotate. Most of the devices in the industry and in our homes



operate with current. The electric current has become a necessity of our life.

## 13.1 ELECTRIC CURRENT

An electric current is caused by the motion of electric charge. If a net charge  $\Delta Q$  passes through any cross section of a conductor in time  $\Delta t$ , we say that an electric current  $I$  has been established through the conductor where

$$I = \frac{\Delta Q}{\Delta t} \quad \dots\dots\dots (13.1)$$

The SI unit of current is ampere and it is a current due to flow of charge at the rate of one coulomb per second.

Motion of electric charge which causes an electric current is due to the flow of charge carriers. In case of metallic conductors, the charge carriers are electrons. The charge carriers in electrolyte are positive and negative ions e.g., in a  $\text{CuSO}_4$  solution the charge carriers are  $\text{Cu}^{++}$  and  $\text{SO}_4^{--}$  ions. In gases, the charge carriers are electrons and ions.

### Current Direction

Early scientists regarded an electric current as a flow of positive charge from positive to negative terminal of the battery through an external circuit. Later on, it was found that a current in metallic conductors is actually due to the flow of negative charge carriers called electrons moving in the opposite direction i.e., from negative to positive terminal of the battery, but it is a convention to take the direction of current as the direction in which positive charges flow. This current is referred as conventional current. The reason is that it has been found experimentally that positive charge moving in one direction is equivalent in all external effects to a negative charge moving in the opposite direction. As the current is measured by its external effects so a current due to motion of negative charges, after reversing its direction of flow can be substituted by an equivalent current due to flow of positive charges. Thus

#### Interesting Information



When eel senses danger, it turns itself into a living battery. Any one who attacks this fish is likely to get a shock. The potential difference between the head and tail of an electric eel can be up to 600 V.

**The conventional current in a circuit is defined as that equivalent current which passes from a point at higher potential to a point at a lower potential as if it represented a movement of positive charges.**

While analyzing the electric circuit, we use the direction of the current according to the above mentioned convention.



If we wish to refer to the motion of electrons, we use the term electronic current (Fig. 13.1).

### Current Through a Metallic Conductor

In a metal, the valence electrons are not attached to individual atoms but are free to move about within the body. These electrons are known as free electrons. The free electrons are in random motion just like the molecules of a gas in a container and they act as charge carriers in metals. The speed of randomly moving electrons depends upon temperature.

If we consider any section of metallic wire, the rate at which the free electrons pass through it from right to left is the same as the rate at which they pass from left to right (Fig. 13.2 a). As a result the current through the wire is zero. If the ends of the wire are connected to a battery, an electric field  $E$  will be set up at every point within the wire (Fig. 13.2 b). The free electrons will now experience a force in the direction opposite to  $E$ . As a result of this force the free electrons acquire a motion in the direction of  $-E$ . It may be noted that the force experienced by the free electrons does not produce a net acceleration because the electrons keep on colliding with the atoms of the conductor. The overall effect of these collisions is to transfer the energy of accelerating electrons to the lattice with the result that the electrons acquire an average velocity, called the drift velocity in the direction of  $-E$  (Fig. 13.2 b). The drift velocity is of the order of  $10^{-3} \text{ms}^{-1}$ , whereas the velocity of free electrons at room temperature due to their thermal motion is several hundred kilometres per second.

Thus, when an electric field is established in a conductor, the free electrons modify their random motion in such a way that they drift slowly in a direction opposite to the field. In other words the electrons, in addition to their violent thermal motion, acquire a constant drift velocity due to which a net directed motion of charges takes place along the wire and a current begins to flow through it. A steady current is established in a wire when a constant potential difference is maintained across it which generates the requisite electric field  $E$  along the wire.

**Example 13.1:**  $1.0 \times 10^7$  electrons pass through a conductor in  $1.0 \mu\text{s}$ . Find the current in ampere flowing through the conductor. Electronic charge is  $1.6 \times 10^{-19} \text{C}$ .

**Solution:** Number of electrons =  $n = 1.0 \times 10^7$

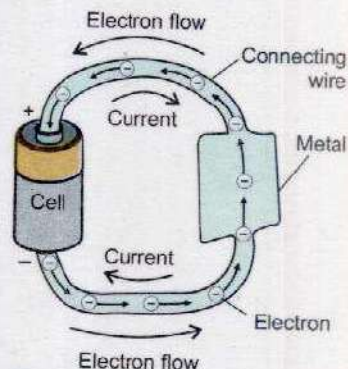


Fig. 13.1

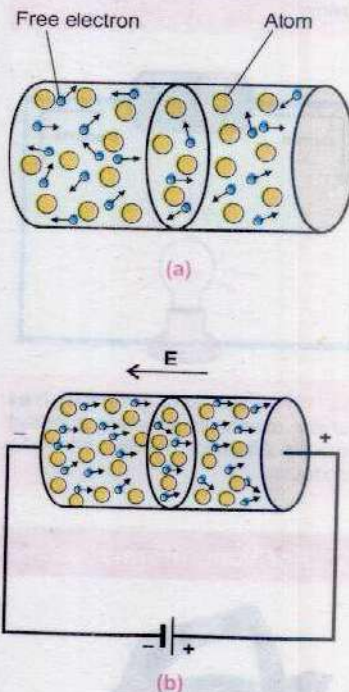
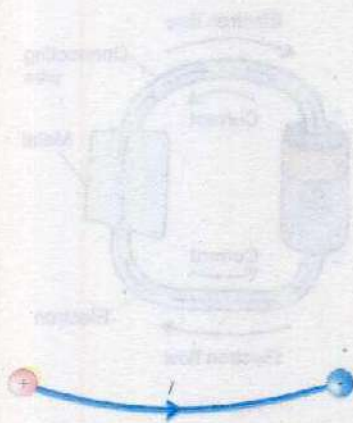
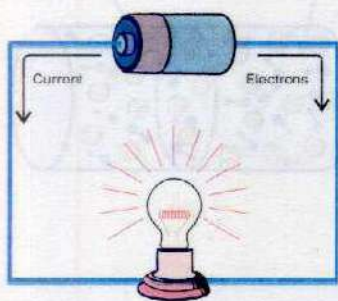


Fig. 13.2





**Fig. 13.3** Conventional current flows from higher to lower potential through a wire.



**Fig. 13.4** A source of current such as battery maintains a nearly constant potential difference between ends of a conductor.

### For Your Information



Heating effect of current is used in electric kettle.

Charge on an electron =  $e = 1.6 \times 10^{-19} \text{ C}$

Time =  $\Delta t = 1.0 \mu\text{s}$

Current  $I$  through the conductor is given by

$$I = \frac{\Delta Q}{\Delta t} = \frac{ne}{\Delta t}$$

$$I = \frac{1.0 \times 10^7 \times 1.6 \times 10^{-19} \text{ C}}{1.0 \times 10^{-6} \text{ s}} = 1.6 \times 10^{-6} \text{ Cs}^{-1} = 1.6 \times 10^{-6} \text{ A}$$

## 13.2 SOURCE OF CURRENT

When two conductors at different potentials are joined by a metallic wire, current will flow through the wire. The current continues to flow from higher potential to the lower potential until both are at the same potential (Fig. 13.3). After this the current ceases to flow. Thus the current through the wire decreases from a maximum value to zero. In order to have a constant current the potential difference across the conductors or the ends of the wire should be maintained constant. This is achieved by connecting the ends of the wire to the terminals of a device called a source of current (Fig. 13.4).

Every source of current converts some non electrical energy such as chemical, mechanical, heat or solar energy into electrical energy. There are many types of sources of current. A few examples are mentioned below:

- (i) Cells (primary as well as secondary) which convert chemical energy into electrical energy.
- (ii) Electric generators which convert mechanical energy into electrical energy.
- (iii) Thermo-couples which convert heat energy into electrical energy.
- (iv) Solar cells which convert sunlight directly into electrical energy.

## 13.3 EFFECTS OF CURRENT

The presence of electric current can be detected by the various effects which it produces. The obvious effects of the current are:

- (i) Heating effect
- (ii) Magnetic effect
- (iii) Chemical effect



## Heating Effect

Current flows through a metallic wire due to motion of free electrons. During the course of their motion, they collide frequently with the atoms of the metal. At each collision, they lose some of their kinetic energy and give it to atoms with which they collide. Thus as the current flows through the wire, it increases the kinetic energy of the vibrations of the metal atoms. i.e., it generates heat in the wire. It is found that the heat  $H$  produced by a current  $I$  in the wire of resistance  $R$  during a time interval  $t$  is given by

$$H = I^2 R t$$

The heating effect of current is utilized in electric heaters, kettles, toasters and electric irons etc.

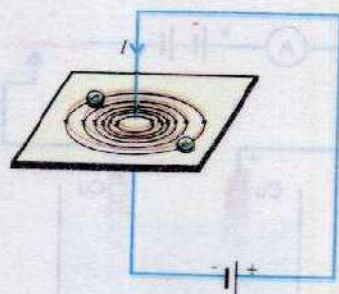
## Magnetic Effect

The passage of current is always accompanied by a magnetic field in the surrounding space. The strength of the field depends upon the value of current and the distance from the current element. The pattern of the field produced by a current carrying straight wire, a coil and a solenoid is shown in Fig. 13.5 (a, b & c). Magnetic effect is utilized in the detection and measurement of current. All the machines involving electric motors also use the magnetic effect of current.

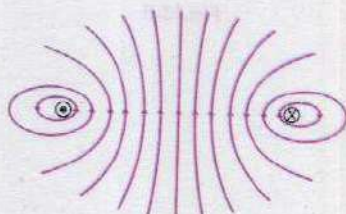
## Chemical Effect

Certain liquids such as dilute sulphuric acid or copper sulphate solution conduct electricity due to some chemical reactions that take place within them. The study of this process is known as electrolysis. The chemical changes produced during the electrolysis of a liquid are due to chemical effects of the current. It depends upon the nature of the liquid and the quantity of electricity passed through the liquid.

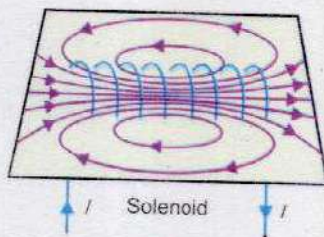
The liquid which conducts current is known as electrolyte. The material in the form of wire or rod or plate which leads the current into or out of the electrolyte is known as electrode. The electrode connected with the positive terminal of the current source is called anode and that connected with negative terminal is known as cathode. The vessel containing the two electrodes and the liquid is known as voltameter. As an example we will consider the electrolysis of copper sulphate solution. The voltameter contains dilute solution of copper sulphate. The anode and cathode are both copper plates



(a)



(b)



(c)

Fig. 13.5



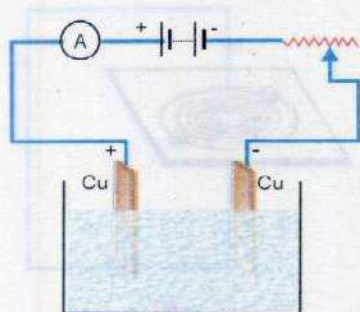


Fig.13.6

(Fig. 13.6). When copper sulphate is dissolved in water, it dissociates into  $\text{Cu}^{2+}$  and  $\text{SO}_4^{2-}$  ions. On passing current through the voltameter.  $\text{Cu}^{2+}$  moves towards the cathode and the following reaction takes place.



The copper atoms thus formed are deposited at cathode plate. While copper is being deposited at the cathode, the  $\text{SO}_4^{2-}$  ions move towards the anode. Copper atoms from the anode go into the solution as copper ions which combine with sulphate ions to form copper sulphate.



As the electrolysis proceeds, copper is continuously deposited on the cathode while an equal amount of copper from the anode is dissolved into the solution and the density of copper sulphate solution remains unaltered.

This example also illustrates the basic principle of electroplating - a process of coating a thin layer of some expensive metal (gold, silver etc.) on an article of some cheap metal.

### 13.4 OHM'S LAW

We have seen that when a battery is connected across a conductor, an electric current begins to flow through it. How much current flows through the conductor when a certain potential difference is set up across its ends? The answer to this question was given by a German Physicist George Simon Ohm. He showed by elaborate experiments that the current through a metallic conductor is directly proportional to the potential difference across its ends. This fact is known as Ohm's law which states that

**"The current flowing through a conductor is directly proportional to the potential difference across its ends provided the physical state such as temperature etc. of the conductor remains constant".**

Symbolically Ohm's law can be written as

$$V \propto I$$

$$\text{It implies that } V = RI \quad \dots \dots \dots (13.2)$$

where  $R$ , the constant of proportionality is called the resistance of the conductor. The value of the resistance depends upon the nature, dimensions and the physical state of the conductor. In fact the resistance is a measure of the



opposition to the motion of electrons due to their continuous bumping with the atoms of the lattice. The unit of resistance is ohm. A conductor has a resistance of 1 ohm if a current of 1 ampere flows through it when a potential difference of 1 volt is applied across its ends. The symbol of ohm is  $\Omega$ . If  $I$  is measured in amperes,  $V$  in volts, then  $R$  is measured in ohms i.e.,

$$R(\text{ohms}) = \frac{V(\text{volts})}{I(\text{amperes})} \dots\dots\dots (13.3)$$

A sample of a conductor is said to obey Ohm's law if its resistance  $R$  remains constant that is, the graph of its  $V$  versus  $I$  is exactly a straight line (Fig. 13.7). A conductor which strictly obeys Ohm's law is called ohmic. However, there are devices, which do not obey Ohm's law i.e., they are non ohmic. The examples of non ohmic devices are filament bulbs and semiconductor diodes.

Let us apply a certain potential difference across the terminals of a filament lamp and measure the resulting current passing through it. If we repeat the measurement for different values of potential difference and draw a graph of voltage  $V$  versus current  $I$ , it will be seen that the graph is not a straight line (Fig. 13.8). It means that a filament is a non ohmic device. This deviation of  $I - V$  graph from straight line is due to the increase in the resistance of the filament with temperature - a topic which is discussed in the next section. As the current passing through the filament is increased from zero, the graph is a straight line in the initial stage because the change in the resistance of the filament with temperature due to small current is not appreciable. As the current is further increased, the resistance of the filament continues to increase due to rise in its temperature.

Another example of non ohmic device is a semiconductor diode. The current - voltage plot of such a diode is shown in Fig. 13.9. The graph is not a straight line so semiconductor is also a non ohmic device.

### Review of Series and Parallel Combinations of Resistors

In an electrical circuit, usually, a number of resistors are connected together. There are two arrangements in which resistors can be connected with each other, one is known as series arrangement and other one as parallel arrangement.

If the resistors are connected end to end such that the same current passes through all of them, they are said to be connected in series as shown in Fig. 13.10(a). There

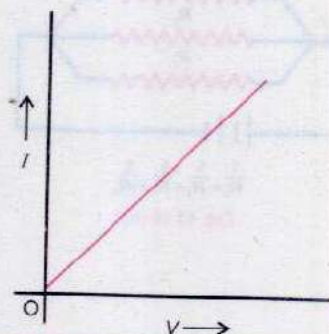


Fig. 13.7 Current - voltage graph of an ohmic material.

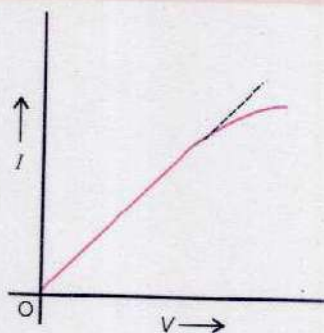


Fig.13.8

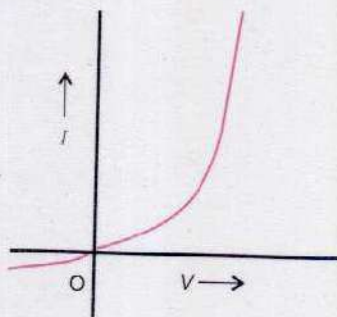


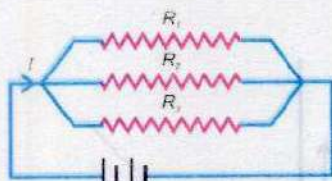
Fig.13.9



$$R_s = R_1 + R_2 + R_3$$

Fig.13.10 (a)





$$\frac{1}{R_e} = \frac{1}{R_1} + \frac{1}{R_2} + \frac{1}{R_3}$$

Fig. 13.10 (b)

equivalent resistance  $R_e$  is given by

$$R_e = R_1 + R_2 + R_3 + \dots \quad (13.4)$$

In parallel arrangement a number of resistors are connected side by side with their ends joined together at two common points as shown in Fig 13.10(b). The equivalent resistance  $R_e$  of this arrangement is given by

$$\frac{1}{R_e} = \frac{1}{R_1} + \frac{1}{R_2} + \frac{1}{R_3} + \dots \quad (13.5)$$

### 13.5 RESISTIVITY AND ITS DEPENDENCE UPON TEMPERATURE

It has been experimentally seen that the resistance  $R$  of a wire is directly proportional to its length  $L$  and inversely proportional to its cross sectional area  $A$ . Expressing mathematically we have

$$R \propto \frac{L}{A}$$

or 
$$R = \rho \frac{L}{A} \quad (13.6)$$

where  $\rho$  is a constant of proportionality known as resistivity or specific resistance of the material of the wire. It may be noted that resistance is the characteristic of a particular wire whereas the resistivity is the property of the material of which the wire is made. From Eq. 13.6 we have

$$\rho = \frac{RA}{L} \quad (13.7)$$

The above equation gives the definition of resistivity as the resistance of a metre cube of a material. The SI unit of resistivity is ohm-metre ( $\Omega \text{ m}$ ).

Conductance is another quantity used to describe the electrical properties of materials. In fact conductance is the reciprocal of resistance i.e.,

$$\text{Conductance} = \frac{1}{\text{resistance } (R)}$$

The SI unit of conductance is mho or siemen.

Likewise conductivity,  $\sigma$  is the reciprocal of resistivity i.e.,

$$\sigma = \frac{1}{\rho} \quad (13.8)$$



The SI unit of conductivity is  $\text{ohm}^{-1} \text{m}^{-1}$  or  $\text{mh m}^{-1}$ . Resistivity of various materials are given in Table 13.1.

It may be noted from Table 13.1 that silver and copper are two best conductors. That is the reason that most electric wires are made of copper.

The resistivity of a substance depends upon the temperature also. It can be explained by recalling that the resistance offered by a conductor to the flow of electric current is due to collisions, which the free electrons encounter with atoms of the lattice. As the temperature of the conductor rises, the amplitude of vibration of the atoms in the lattice increases and hence, the probability of their collision with free electrons also increases. One may say that the atoms then offer a bigger target, that is, the collision cross-section of the atoms increases with temperature. This makes the collisions between free electrons and the atoms in the lattice more frequent and hence, the resistance of the conductor increases.

Experimentally the change in resistance of a metallic conductor with temperature is found to be nearly linear over a considerable range of temperature above and below  $0^\circ\text{C}$  (Fig. 13.11). Over such a range the fractional change in resistance per kelvin is known as the temperature coefficient of resistance i.e.,

$$\alpha = \frac{R_t - R_0}{R_0 t} \quad \dots\dots\dots (13.9)$$

where  $R_0$  and  $R_t$  are resistances at temperature  $0^\circ\text{C}$  and  $t^\circ\text{C}$ . As resistivity  $\rho$  depends upon the temperature, Eq. 13.6 gives

$$R_t = \rho_t L/A \quad \text{and} \quad R_0 = \rho_0 L/A$$

Substituting the values of  $R_t$  and  $R_0$  in Eq. 13.9, we get

$$\text{as} \quad \alpha = \frac{\rho_t - \rho_0}{\rho_0 t} \quad \dots\dots\dots (13.10)$$

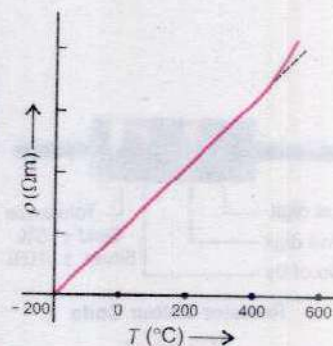
where  $\rho_0$  is the resistivity of a conductor at  $0^\circ\text{C}$  and  $\rho_t$  is the resistivity at  $t^\circ\text{C}$ . Values of temperature co-efficients of resistivity of some substances are also listed in Table 13.1.

There are some substances like germanium, silicon etc., whose resistance decreases with increase in temperature. i.e., these substances have negative temperature coefficients.

**Example 13.2:** 0.75 A current flows through an iron wire when a battery of 1.5 V is connected across its ends. The

**Table 13.1**

Substance	$\rho$ ( $\Omega\text{m}$ )	$\alpha$ ( $\text{K}^{-1}$ )
Silver	$1.52 \times 10^{-8}$	0.00380
Copper	$1.54 \times 10^{-8}$	0.00390
Gold	$2.27 \times 10^{-8}$	0.00340
Aluminium	$2.63 \times 10^{-8}$	0.00390
Tungsten	$5.00 \times 10^{-8}$	0.00460
Iron	$11.00 \times 10^{-8}$	0.00520
Platinum	$11.00 \times 10^{-8}$	0.00520
Constantan	$49.00 \times 10^{-8}$	0.00001
Mercury	$94.00 \times 10^{-8}$	0.00091
Nichrome	$100.0 \times 10^{-8}$	0.00020
Carbon	$3.5 \times 10^{-5}$	-0.0005
Germanium	0.5	-0.05
Silicon	20-2300	-0.07



**Fig. 13.11** Variation of resistivity of Cu with temperature.

**Interesting Information**

Inspectors can easily check the reliability of a concrete bridge made with carbon fibers. The fibers conduct electricity. If sensors show that electrical resistance is increasing over time the fibers are separating because of cracks.



length of the wire is 5.0 m and its cross sectional area is  $2.5 \times 10^{-7} \text{ m}^2$ . Compute the resistivity of iron.

**Solution:**

The resistance  $R$  of the wire can be calculated by Eq. 13.2 i.e.,

$$R = \frac{V}{I} = \frac{1.5 \text{ V}}{0.75 \text{ A}} = 2.0 \text{ VA}^{-1} = 2.0 \Omega$$

The resistivity  $\rho$  of iron of which the wire is made is given by

$$\rho = R \frac{A}{L} = \frac{2.0 \Omega \times 2.5 \times 10^{-7} \text{ m}^2}{5.0 \text{ m}} = 1.0 \times 10^{-7} \Omega \text{ m}$$

**Example 13.3:** A platinum wire has resistance of  $10 \Omega$  at  $0^\circ\text{C}$  and  $20 \Omega$  at  $273^\circ\text{C}$ . Find the value of temperature coefficient of resistance of platinum.

**Solution:**

$$R_0 = 10 \Omega, R_t = 20 \Omega, t = 273 \text{ K} - 0^\circ\text{C} = 273 \text{ K}$$

Temperature coefficient of resistance can be found by

$$\alpha = \frac{R_t - R_0}{R_0 t} = \frac{20 \Omega - 10 \Omega}{10 \Omega \times 273 \text{ K}} = \frac{1}{273 \text{ K}} = 3.66 \times 10^{-3} \text{ K}^{-1}$$

**Table 13.2 The Colour Code**

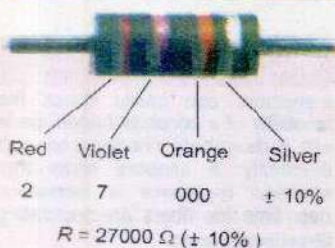
Colour	Value
Black	0
Brown	1
Red	2
Orange	3
Yellow	4
Green	5
Blue	6
Violet	7
Gray	8
White	9



**Resistor Colour Code**

**Fig. 13.12**

### For Your Information



## 13.6 COLOUR CODE FOR CARBON RESISTANCES

Carbon resistors are most common in electronic equipment. They consist of a high-grade ceramic rod or cone (called the substrate) on which is deposited a thin resistive film of carbon. The numerical value of their resistance is indicated by a colour code which consists of bands of different colours printed on the body of the resistor. The colour used in this code and the digits represented by them are given in Table 13.2.

Usually the code consists of four bands (Fig. 13.12). Starting from left to right, the colour bands are interpreted as follows:

1. The first band indicates the first digit in the numerical value of the resistance.
2. The second band gives the second digit.
3. The third band is decimal multiplier i.e., it gives the number of zeros after the first two digits.
4. The fourth band gives resistance tolerance. Its colour is either silver or gold. Silver band indicates a tolerance of  $\pm 10\%$ , a gold band shows a tolerance of  $\pm 5\%$ .



$\pm 5\%$ . If there is no fourth band, tolerance is understood to be  $+20\%$ . By tolerance, we mean the possible variation from the marked value. For example, a  $1000\ \Omega$  resistor with a tolerance of  $\pm 10\%$  will have an actual resistance anywhere between  $900\ \Omega$  and  $1100\ \Omega$ .

## Rheostat

It is a wire wound variable resistance. It consists of a bare manganin wire wound over an insulating cylinder. The ends of the wire are connected to two fixed terminals A and B (Fig. 13.13 a). A third terminal C is attached to a sliding contact which can also be moved over the wire.

A rheostat can be used as a variable resistor as well as a potential divider. To use it as a variable resistor one of the fixed terminal say A and the sliding terminal C are inserted in the circuit (Fig. 13.13 b). In this way the resistance of the wire between A and the sliding contact C is used. If the sliding contact is shifted away from the terminal A, the length and hence the resistance included in the circuit increases and if the sliding contact is moved towards A, the resistance decreases. A rheostat can also be used as a potential divider.

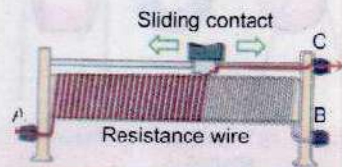
This is illustrated in Fig. 13.14. A potential difference  $V$  is applied across the ends A and B of the rheostat with the help of a battery. If  $R$  is the resistance of wire AB, the current  $I$  passing through it is given by  $I = V/R$ .

The potential difference between the portion BC of the wire AB is given by

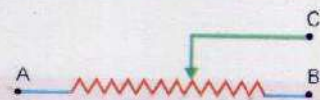
$$V_{BC} = \text{current} \times \text{resistance}$$

$$= \frac{V}{R} \times r = \frac{r}{R} V \quad \dots\dots\dots (13.11)$$

where  $r$  is the resistance of the portion BC of the wire. The circuit shown in Fig. 13.14 is known as potential divider. Eq.13.11 shows that this circuit can provide at its output terminals a potential difference varying from zero to the full potential difference of the battery depending on the position of the sliding contact. As the sliding contact C is moved towards the end B, the length and hence the resistance  $r$  of the portion BC of the wire decreases which according to Eq. 13.11, decreases  $V_{BC}$ . On the other hand if the sliding contact C is moved towards the end A, the output voltage  $V_{BC}$  increases.

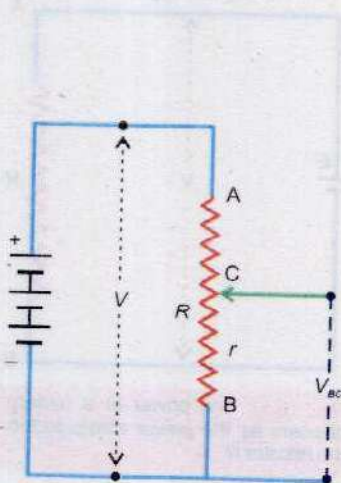


(a) A Rheostat



(b) Its use as variable resistor

Fig. 13.13



Use of rheostat as potential divider

Fig.13.14



## Thermistors

A thermistor is a heat sensitive resistor. Most thermistors have negative temperature coefficient of resistance i.e., the resistance of such thermistors decreases when their temperature is increased. Thermistors with positive temperature coefficient are also available.

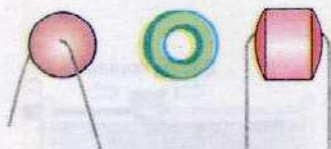


Fig. 13.15 Thermistors of different shapes.

Thermistors are made by heating under high pressure semiconductor ceramic made from mixtures of metallic oxides of manganese, nickel, cobalt, copper, iron etc. These are pressed into desired shapes and then baked at high temperature. Different types of thermistors are shown in Fig. 13.15. They may be in the form of beads, rods or washers.

Thermistors with high negative temperature coefficient are very accurate for measuring low temperatures especially near 10 K. The higher resistance at low temperature enables more accurate measurement possible.

Thermistors have wide applications as temperature sensors i.e., they convert changes of temperature into electrical voltage which is duly processed.

### For Your Information

A zero-ohm resistor is indicated by a single black colour band around the body of the resistor.

## 13.7 ELECTRICAL POWER AND POWER DISSIPATION IN RESISTORS

Consider a circuit consisting of a battery  $E$  connected in series with a resistance  $R$  (Fig. 13.16). A steady current  $I$  flows through the circuit and a steady potential difference  $V$  exists between the terminals A and B of the resistor  $R$ . Terminal A, connected to the positive pole of the battery, is at a higher potential than the terminal B. In this circuit the battery is continuously lifting charge uphill through the potential difference  $V$ . Using the meaning of potential difference, the work done in moving a charge  $\Delta Q$  up through the potential difference  $V$  is given by

$$\text{Work done} = \Delta W = V \times \Delta Q \dots \dots (13.12)$$

This is the energy supplied by the battery. The rate at which the battery is supplying electrical energy is the power output or electrical power of the battery. Using the definition of power we have

$$\text{Electrical power} = \frac{\text{Energy supplied}}{\text{Time taken}} = V \frac{\Delta Q}{\Delta t}$$

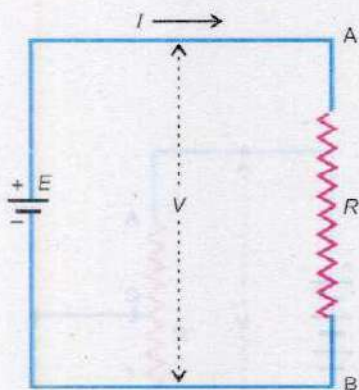


Fig. 13.16 The power of a battery appears as the power dissipated in the resistor  $R$ .



Since  $I = \frac{\Delta Q}{\Delta t}$ , so

$$\text{Electrical power} = V \times I \quad \dots\dots\dots (13.12a)$$

Eq. 13.12a is a general relation for power delivered from a source of current  $I$  operating on a voltage  $V$ . In the circuit shown in Fig.13.16 the power supplied by the battery is expended or dissipated in the resistor  $R$ . The principle of conservation of energy tells us that the power dissipated in the resistor is also given by Eq. 13.12. a

$$\text{Power dissipated } (P) = V \times I \quad \dots\dots\dots (13.13)$$

Alternative equation for calculating power can be found by substituting  $V = IR$ ,  $I = V/R$  in turn in Eq. 13.13

$$P = V \times I = IR \times I = I^2 R$$

$$P = V \times I = V \times \frac{V}{R} = \frac{V^2}{R}$$

Thus we have three equations for calculating the power dissipated in a resistor.

$$P = V \times I, \quad P = I^2 R, \quad P = \frac{V^2}{R} \quad \dots\dots\dots (13.14)$$

If  $V$  is expressed in volts and  $I$  in amperes, the power is expressed in watts.

### 13.8 ELECTROMOTIVE FORCE (EMF) AND POTENTIAL DIFFERENCE

We know that a source of electrical energy, say a cell or a battery, when connected across a resistance maintains a steady current through it (Fig. 13.17). The cell continuously supplies energy which is dissipated in the resistance of the circuit. Suppose when a steady current has been established in the circuit, a charge  $\Delta Q$  passes through any cross section of the circuit in time  $\Delta t$ . During the course of motion, this charge enters the cell at its low potential end and leaves at its high potential end. The source must supply energy  $\Delta W$  to the positive charge to force it to go to the point of high potential. The emf  $E$  of the source is defined as the energy supplied to unit charge by the cell.

i.e.  $E = \frac{\Delta W}{\Delta Q} \quad \dots\dots\dots (13.15)$

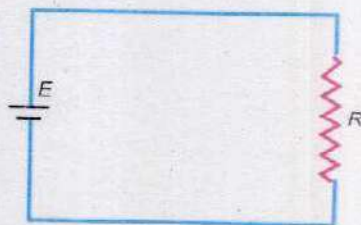


Fig. 13.17 Electromotive force of a cell.



It may be noted that electromotive force is not a force and we do not measure it in newtons. The unit of emf is joule/coulomb which is volt (V).

The energy supplied by the cell to the charge carriers is derived from the conversion of chemical energy into electrical energy inside the cell.

Like other components in a circuit a cell also offers some resistance. This resistance is due to the electrolyte present between the two electrodes of the cell and is called the internal resistance  $r$  of the cell. Thus a cell of emf  $E$  having an internal resistance  $r$  is equivalent to a source of pure emf  $E$  with a resistance  $r$  in series as shown in Fig. 13.18.



Fig. 13.18 An equivalent circuit of a cell of emf  $E$  and internal resistance  $r$ .

Let us consider the performance of a cell of emf  $E$  and internal resistance  $r$  as shown in Fig. 13.19. A voltmeter of infinite resistance measures the potential difference across the external resistance  $R$  or the potential difference  $V$  across the terminals of the cell. The current  $I$  flowing through the circuit is given by

$$I = \frac{E}{R+r}$$

or  $E = IR + Ir$  ..... (13.16)

Here  $IR = V$  is the terminal potential difference of the cell in the presence of current  $I$ . When the switch  $S$  is open, no current passes through the resistance. In this case the voltmeter reads the emf  $E$  as terminal voltage. Thus terminal voltage in the presence of the current (switch on) would be less than the emf  $E$  by  $Ir$ .

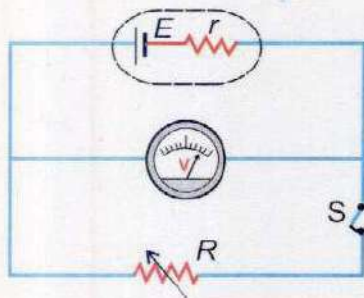


Fig. 13.19 The terminal potential difference  $V$  of a cell is  $E - Ir$

Let us interpret the Eq. 13.16 on energy considerations. The left side of this equation is the emf  $E$  of the cell which is equal to energy gained by unit charge as it passes through the cell from its negative to positive terminal. The right side of the equation gives an account of the utilization of this energy as the current passes the circuit. It states that, as a unit charge passes through the circuit, a part of this energy equal to  $Ir$  is dissipated into the cell and the rest of the energy is dissipated into the external resistance  $R$ . It is given by potential drop  $IR$ . Thus the emf gives the energy supplied to unit charge by the cell and the potential drop across the various elements account for the dissipation of this energy into other forms as the unit charge passes through these elements.

The emf is the "cause" and potential difference is its "effect". The emf is always present even when no current is drawn



through the battery or the cell, but the potential difference across the conductor is zero when no current flows through it.

**Example 13.4:** The potential difference between the terminals of a battery in open circuit is 2.2 V. When it is connected across a resistance of  $5.0 \Omega$ , the potential falls to 1.8 V. Calculate the current and the internal resistance of the battery.

**Solution:**

Given  $E = 2.2 \text{ V}$ ,  $R = 5.0 \Omega$ ,  $V = 1.8 \text{ V}$

We are to calculate  $I$  and  $r$ .

We have  $V = IR$

$$\text{or } I = \frac{V}{R} = \frac{1.8 \text{ V}}{5.0 \Omega} = 0.36 \text{ A}$$

Internal resistance  $r$  can be calculated by using

$$E = V + Ir$$

$$\text{or } 2.2 \text{ V} = 1.8 \text{ V} + 0.36 \text{ A} \times r$$

$$\text{or } r = 1.11 \text{ V A}^{-1} = 1.11 \Omega$$

### Maximum Power Output

In the circuit of Fig. 13.19, as the current  $I$  flows through the resistance  $R$ , the charges flow from a point of higher potential to a point of lower potential and as such, they lose potential energy. If  $V$  is the potential difference across  $R$ , the loss of potential energy per second is  $VI$ . This loss of energy per second appears in other forms of energy and is known as power delivered to  $R$  by current  $I$ .

$$\therefore \text{Power delivered to } R = P_{\text{out}} = VI$$

$$= I^2 R \quad (\because V = IR)$$

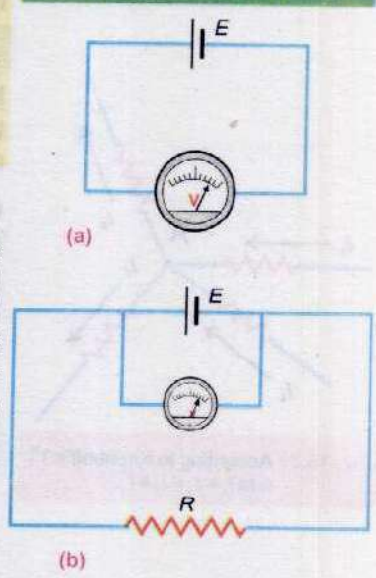
As

$$I = \frac{E}{R+r}$$

$$P_{\text{out}} = \frac{E^2 R}{(R+r)^2} = \frac{E^2 R}{(R-r)^2 + 4Rr} \dots \dots \dots (13.17)$$

when  $R = r$ , the denominator of the expression of  $P_{\text{out}}$  is least and so  $P_{\text{out}}$  is then a maximum. Thus we see that maximum power is delivered to a resistance (load), when the internal resistance of the source equals the load resistance. The

### Do You Know?



A voltmeter connected across the terminals of a cell measures (a) the emf of the cell on open circuit, (b) the terminal potential difference on a closed circuit.



value of this maximum output power as given by Eq. 13.17 is  $\frac{E^2}{4R}$ .

### 13.9 KIRCHHOFF'S RULES

Ohm's law and rules of series and parallel combination of resistance are quite useful to analyze simple electrical circuits consisting of more than one resistance. However such a method fails in the case of complex networks consisting of a number of resistors, and a number of voltage sources. Problems of such networks can be solved by a system of analysis, which is based upon two rules, known as Kirchhoff's rules.

#### Kirchhoff's First Rule

It states that the sum of all the currents meeting at a point in the circuit is zero i.e.,

$$\sum I = 0 \quad \dots\dots\dots (13.18)$$

It is a convention that a current flowing towards a point is taken as positive and that flowing away from a point is taken as negative.

Consider a situation where four wires meet at a point A (Fig. 13.20). The currents flowing into the point A are  $I_1$  and  $I_2$  and currents flowing away from the point are  $I_3$  and  $I_4$ . According to the convention currents  $I_1$  and  $I_2$  are positive and currents  $I_3$  and  $I_4$  are negative. Applying Eq. 13.18 we have

$$I_1 + I_2 + (-I_3) + (-I_4) = 0$$

or  $I_1 + I_2 = I_3 + I_4 \quad \dots\dots\dots (13.19)$

Using Eq. 13.19 Kirchhoff's first rule can be stated in other words as

**The sum of all the currents flowing towards a point is equal to the sum of all the currents flowing away from the point.**

Kirchhoff's first rule which is also known as Kirchhoff's point rule is a manifestation of law of conservation of charge. If there is no sink or source of charge at a point, the total charge flowing towards the point must be equal to the total charge flowing away from it.

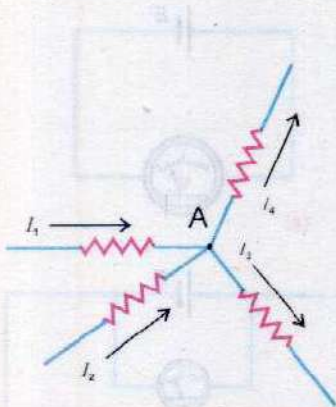


Fig. 13.20 According to Kirchhoff's 1<sup>st</sup> rule  $I_1 + I_2 = I_3 + I_4$ .



## Kirchhoff's Second Rule

It states that the algebraic sum of voltage changes in a closed circuit or a loop must be equal to zero. Consider a closed circuit shown in Fig. 13.21. The direction of the current  $I$  flowing through the circuit depends on the cell having the greater emf. Suppose  $E_1$  is greater than  $E_2$ , so the current flows in counter clockwise direction (Fig. 13.21). We know that a steady current is equivalent to a continuous flow of positive charges through the circuit. We also know that a voltage change or potential difference is equal to the work done on a unit positive charge or energy gained or lost by it in moving from one point to the other. Thus when a positive charge  $\Delta Q$  due to the current  $I$  in the closed circuit (Fig. 13.21), passes through the cell  $E_1$  from low (-ve) to high potential (+ve), it gains energy because work is done on it. Using Eq. 13.12 the energy gain is  $E_1 \Delta Q$ . When the current passes through the cell  $E_2$  it loses energy equal to  $-E_2 \Delta Q$  because here the charge passes from high to low potential. In going through the resistor  $R_1$ , the charge  $\Delta Q$  loses energy equal to  $-IR_1 \Delta Q$  where  $IR_1$  is potential difference across  $R_1$ . The minus sign shows that the charge is passing from high to low potential. Similarly the loss of energy while passing through the resistor  $R_2$  is  $-IR_2 \Delta Q$ . Finally the charge reaches the negative terminal of the cell  $E_1$ , from where we started. According to the law of conservation of energy the total change in energy of our system is zero. Therefore, we can write

$$E_1 \Delta Q - IR_1 \Delta Q - E_2 \Delta Q - IR_2 \Delta Q = 0$$

$$\text{or } E_1 - IR_1 - E_2 - IR_2 = 0 \quad \dots\dots\dots (13.20)$$

which is Kirchhoff's second rule and it states that

**The algebraic sum of potential changes in a closed circuit is zero.**

We have seen that this rule is simply a particular way of stating the law of conservation of energy in electrical problems.

Before applying this rule for the analysis of complex network it is worthwhile to thoroughly understand the rules for finding the potential changes.

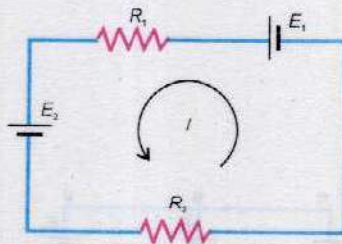


Fig. 13.21 According to Kirchhoff's 2<sup>nd</sup> rule  $E_1 - IR_1 - E_2 - IR_2 = 0$ .



- (i) If a source of emf is traversed from negative to positive terminal, the potential change is positive, it is negative in the opposite direction.
- (ii) If a resistor is traversed in the direction of current, the change in potential is negative, it is positive in the opposite direction.

**Example 13.6:** Calculate the currents in the three resistances of the circuit shown in Fig. 13.22.

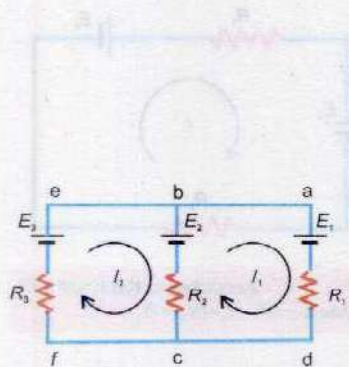
**Solution:**

First we select two loops *abcd* and *ebcfe*. The choice of loops is quite arbitrary, but it should be such that each resistance is included at least once in the selected loops.

After selecting the loops, suppose a current  $I_1$  is flowing in the first loop and  $I_2$  in the second loop, all flowing in the same sense. These currents are called loop currents. The actual currents will be calculated with their help. It should be noted that the sense of the current flowing in all loops should essentially be the same. It may be clockwise or anticlockwise. Here we have assumed it to be clockwise (Fig. 13.22).

We now apply Kirchhoff's second rule to obtain the equations required to calculate the currents through the resistances. We first consider the loop *abcd*. Starting at a point 'a' we follow the loop clockwise. The voltage change while crossing the battery  $E_1$  is  $-E_1$  because the current flows through it from positive to negative. The voltage change across  $R_1$  is  $-I_1 R_1$ . The resistance  $R_2$  is common to both the loops  $I_1$  and  $I_2$  therefore, the currents  $I_1$  and  $I_2$  simultaneously flow through it. The directions of currents  $I_1$  and  $I_2$  as flowing through  $R_2$  are opposite, so we have to decide that which of these currents is to be assigned a positive sign. The convention regarding the sign of the current is that if we are applying the Kirchhoff's second rule in the first loop, then the current of this loop i.e.,  $I_1$  will be assigned a positive sign and all currents, flowing opposite to  $I_1$  have a negative sign. Similarly, while applying Kirchhoff's second rule in the second loop, the current  $I_2$  will be considered as positive and  $I_1$  as negative. Using this convention the current flowing through  $R_2$  is  $(I_1 - I_2)$  and the voltage change across is  $-(I_1 - I_2) R_2$ . The voltage change across the battery  $E_2$  is  $E_2$ . Thus the Kirchhoff's second rule as applied to the loop *abcd* gives

$$-E_1 - I_1 R_1 - (I_1 - I_2) R_2 + E_2 = 0$$



$R_1 = 10 \Omega$ ,  $R_2 = 30 \Omega$ ,  $R_3 = 15 \Omega$   
 $E_1 = 40 \text{ V}$ ,  $E_2 = 60 \text{ V}$ ,  $E_3 = 50 \text{ V}$

Fig. 13.22



Substituting the values, we have

$$-40 \text{ V} - I_1 \times 10 \Omega - (I_1 - I_2) \times 30 \Omega + 60 \text{ V} = 0$$

$$20 \text{ V} - 10 \Omega \times [I_1 + 3(I_1 - I_2)] = 0$$

$$\text{or } 4I_1 - 3I_2 = 2 \text{ V}\Omega^{-1} = 2 \text{ A} \quad \dots\dots\dots (13.21)$$

Similarly applying Kirchhoff's second rule to the loop ebcfe, we get

$$-E_2 - (I_2 - I_1) R_2 - I_2 R_3 + E_3 = 0$$

Substituting the values, we have

$$-60 \text{ V} - (I_2 - I_1) \times 30 \Omega - I_2 \times 15 \Omega + 50 \text{ V} = 0$$

$$-10 \text{ V} - 15 \Omega \times [I_2 + 2(I_2 - I_1)] = 0$$

$$\text{or } 6I_1 - 9I_2 = 2 \text{ V}\Omega^{-1} = 2 \text{ A} \quad \dots\dots\dots (13.22)$$

Solving Eq. 13.21 and Eq. 13.22 for  $I_1$  and  $I_2$ , we get

$$I_1 = \frac{2}{3} \text{ A} \quad \text{and} \quad I_2 = \frac{2}{9} \text{ A}$$

Knowing the values of loop currents  $I_1$  and  $I_2$  the actual current flowing through each resistance of the circuit can be determined. Fig. 13.22 shows that  $I_1$  and  $I_2$  are the actual currents through the resistances  $R_1$  and  $R_3$ . The actual current through  $R_2$  is the difference of  $I_1$  and  $I_2$  and its direction is along the larger current. Thus

The current through  $R_1 = I_1 = \frac{2}{3} \text{ A} = 0.66 \text{ A}$  flowing in the direction of  $I_1$ , i.e., from a to d.

The current through  $R_2 = I_1 - I_2 = \frac{2}{3} \text{ A} - \frac{2}{9} \text{ A} = 0.44 \text{ A}$  flowing in the direction of  $I_1$ , i.e., from c to b.

The current through  $R_3 = I_2 = \frac{2}{9} \text{ A} = 0.22 \text{ A}$  flowing in the direction of  $I_2$ , i.e., from f to e.

### Procedure of Solution of Circuit Problems

After solving the above problem we are in a position to apply the same procedure to analyse other direct current complex networks. While using Kirchhoff's rules in other problems, it is worthwhile to follow the approach given below:

- (i) Draw the circuit diagram.
- (ii) The choice of loops should be such that each resistance is included at least once in the selected loops.



- (iii) Assume a loop current in each loop, all the loop currents should be in the same sense. It may be either clockwise or anticlockwise.
- (iv) Write the loop equations for all the selected loops. For writing each loop equation the voltage change across any component is positive if traversed from low to high potential and it is negative if traversed from high to low potential.
- (v) Solve these equations for the unknown quantities.

### 13.9 WHEATSTONE BRIDGE

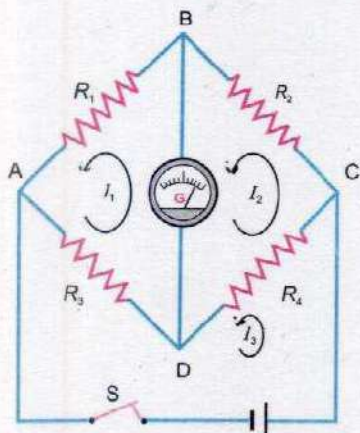


Fig. 13.23 Wheatstone bridge circuit

The Wheatstone bridge circuit shown in Fig. 13.23 consists of four resistances  $R_1$ ,  $R_2$ ,  $R_3$  and  $R_4$  connected in such a way so as to form a mesh ABCDA. A battery is connected between points A and C. A sensitive galvanometer of resistance  $R_g$  is connected between points B and D. If the switch S is closed, a current will flow through the galvanometer. We are to determine the condition under which no current flows through the galvanometer even after the switch is closed. For this purpose we analyse this circuit using Kirchhoff's second rule. We consider the loops ADBA, DCBD and ADCA and assume anticlockwise loop currents  $I_1$ ,  $I_2$  and  $I_3$  through the loops respectively. The Kirchhoff's second rule as applied to loop ADBA gives

$$-I_1 R_1 - (I_1 - I_2) R_g - (I_1 - I_3) R_3 = 0 \quad \dots\dots\dots (13.23)$$

Similarly by applying the Kirchhoff's second rule to loop BCDB we have

$$-I_2 R_2 - (I_2 - I_3) R_4 - (I_2 - I_1) R_g = 0 \quad \dots\dots\dots (13.24)$$

The current flowing through the galvanometer will be zero if,  $I_1 - I_2 = 0$  or  $I_1 = I_2$ . With this condition Eq. 13.23 and Eq. 13.24 reduce to

$$-I_1 R_1 = (I_1 - I_3) R_3 \quad \dots\dots\dots (13.25)$$

$$-I_1 R_2 = (I_2 - I_3) R_4 \quad \dots\dots\dots (13.26)$$

Dividing Eq. 13.25 by Eq. 13.26

$$\frac{R_1}{R_2} = \frac{R_3}{R_4} \quad \dots\dots\dots (13.27)$$

Thus whenever the condition of Eq. 13.27 is satisfied, no current flows through the galvanometer and it shows no deflection, or conversely when the galvanometer in the Wheatstone bridge circuit shows no deflection, Eq. 13.27 is satisfied.



If we connect three resistances  $R_1$ ,  $R_2$  and  $R_3$  of known adjustable values and a fourth resistance  $R_4$  of unknown value and the resistances  $R_1$ ,  $R_2$  and  $R_3$  are so adjusted that the galvanometer shows no deflection then, from the known resistances  $R_1$ ,  $R_2$  and  $R_3$  the unknown resistance  $R_4$  can be determined by using Eq. 13.27.

### 13.10 POTENTIOMETER

Potential difference is usually measured by an instrument called a voltmeter. The voltmeter is connected across the two points in a circuit between which potential difference is to be measured. It is necessary that the resistance of the voltmeter be large compared to the circuit resistance across which the voltmeter is connected. Otherwise an appreciable current will flow through the voltmeter which will alter the circuit current and the potential difference to be measured. Thus the voltmeter can read the correct potential difference only when it does not draw any current from the circuit across which it is connected. An ideal voltmeter would have an infinite resistance.

However, there are some potential measuring instruments such as digital voltmeter and cathode ray oscilloscope which practically do not draw any current from the circuit because of their large resistance and are thus very accurate potential measuring instruments. But these instruments are very expensive and are difficult to use. A very simple instrument which can measure and compare potential differences accurately is a potentiometer.

A potentiometer consists of a resistor  $R$  in the form of a wire on which a terminal  $C$  can slide (Fig. 13.24 a). The resistance between  $A$  and  $C$  can be varied from 0 to  $R$  as the sliding contact  $C$  is moved from  $A$  to  $B$ . If a battery of emf  $E$  is connected across  $R$  (Fig. 13.24 b), the current flowing through it is  $I = E/R$ . If we represent the resistance between  $A$  and  $C$  by  $r$ , the potential drop between these points will be  $rl = r E/R$ . Thus as  $C$  is moved from  $A$  to  $B$ ,  $r$  varies from 0 to  $R$  and the potential drop between  $A$  and  $C$  changes from 0 to  $E$ . Such an arrangement also known as potential divider can be used to measure the unknown emf of a source by using the circuit shown in Fig. 13.25. Here  $R$  is in the form of a straight wire of uniform area of cross section. A source of potential, say a cell whose emf  $E_x$  is to be measured, is connected between  $A$  and the sliding contact  $C$  through a galvanometer  $G$ . It should be noted that the positive terminal of  $E_x$  and that of the potential divider are connected to the same point  $A$ . If, in

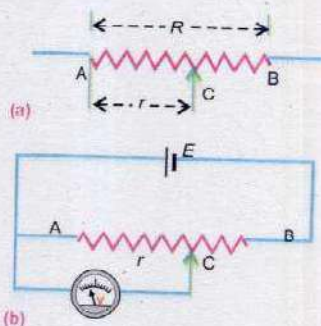


Fig. 13.24

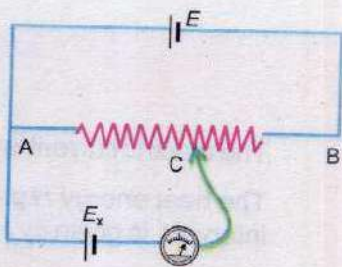


Fig. 13.25



the loop AGCA, the point C and the negative terminal of  $E_x$  are at the same potential then the two terminals of the galvanometer will be at the same potential and no current will flow through the galvanometer. Therefore, to measure the potential  $E_x$ , the position of C is so adjusted that the galvanometer shows no deflection. Under this condition, the emf  $E_x$  of the cell is equal to the potential difference between A and C whose value  $Er/R$  is known. In case of a wire of uniform cross section, the resistance is proportional to the length of the wire. Therefore, the unknown emf is also given by

$$E_x = E \frac{r}{R} = E \frac{\ell}{L} \quad \dots\dots\dots (13.28)$$

where  $L$  is the total length of the wire AB and  $\ell$  is its length from A to C, after C has been adjusted for no deflection. As the maximum potential that can be obtained between A and C is  $E$ , so the unknown emf  $E_x$  should not exceed this value, otherwise the null condition will not be obtained. It can be seen that the unknown emf  $E_x$  is determined when no current is drawn from it and therefore, potentiometer is one of the most accurate methods for measuring potential.

The method for measuring the emf of a cell as described above can be used to compare the emfs  $E_1$  and  $E_2$  of two cells. The balancing lengths  $\ell_1$  and  $\ell_2$  are found separately for the two cells. Then,

$$E_1 = E \frac{\ell_1}{L} \quad \text{and} \quad E_2 = E \frac{\ell_2}{L}$$

Dividing these two equations, we get

$$\frac{E_1}{E_2} = \frac{\ell_1}{\ell_2} \quad \dots\dots\dots (13.29)$$

So the ratio of the emfs is equal to ratio of the balancing lengths.

## SUMMARY

- The electric current is said to be caused by the motion of electric charge.
- The heat energy  $H$  produced by a current  $I$  in the wire of resistance  $R$  during a time interval  $t$  is given by  $H = I^2 R t$
- The passage of current is always accompanied by a magnetic field in the surrounding space.



- Certain liquids conduct electricity due to some chemical reaction that takes place within them. The study of this process is known as electrolysis.
- The potential difference  $V$  across the ends of a conductor is directly proportional to the current  $I$  flowing through it provided the physical state such as temperature etc. of the conductor remains constant.
- The fractional change in resistance per kelvin is known as temperature coefficient of resistance.
- A thermistor is a heat sensitive resistor. Most thermistors have negative temperature coefficient of resistance.
- Electrical power  $P = VI = I^2R = \frac{V^2}{R}$
- The emf  $E$  of the source is the energy supplied to unit charge by the cell.
- The sum of all the currents meeting at a point in a circuit is zero is the Kirchhoff's first rule.
- The algebraic sum of potential changes in a closed circuit is zero is known as Kirchhoff's second rule.

### QUESTIONS

- 13.1 A potential difference is applied across the ends of a copper wire. What is the effect on the drift velocity of free electrons by
- increasing the potential difference
  - decreasing the length and the temperature of the wire
- 13.2 Do bends in a wire affect its electrical resistance? Explain.
- 13.3 What are the resistances of the resistors given in the figures A and B? What is the tolerance of each? Explain what is meant by the tolerance?

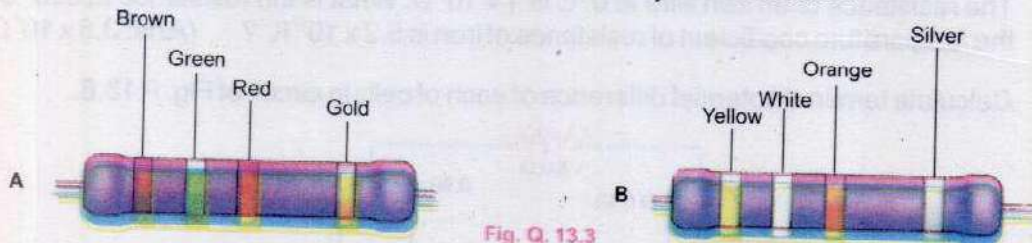


Fig. Q. 13.3

- 13.4 Why does the resistance of a conductor rise with temperature?
- 13.5 What are the difficulties in testing whether the filament of a lighted bulb obeys Ohm's law?



- 13.6 Is the filament resistance lower or higher in a 500 W, 220 V light bulb than in a 100 W, 220 V bulb?
- 13.7 Describe a circuit which will give a continuously varying potential.
- 13.8 Explain why the terminal potential difference of a battery decreases when the current drawn from it is increased?
- 13.9 What is Wheatstone bridge? How can it be used to determine an unknown resistance?

### PROBLEMS

- 13.1 How many electrons pass through an electric bulb in one minute if the 300 mA current is passing through it? (Ans:  $1.12 \times 10^{20}$ )
- 13.2 A charge of 90 C passes through a wire in 1 hour and 15 minutes. What is the current in the wire? (Ans: 20 mA)
- 13.3 Find the equivalent resistance of the circuit (Fig.P.13.3), total current drawn from the source and the current through each resistor.

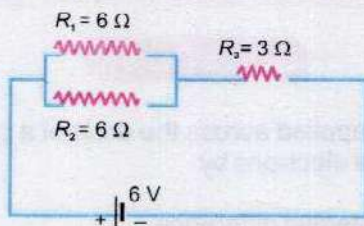


Fig. P. 13.3

(Ans:  $6.0 \Omega$ , 1.0 A, 0.5 A, 0.5 A, 1.0 A)

- 13.4 A rectangular bar of iron is 2.0 cm by 2.0 cm in cross section and 40 cm long. Calculate its resistance if the resistivity of iron is  $11 \times 10^{-8} \Omega\text{m}$ . (Ans:  $1.1 \times 10^{-4} \Omega$ )
- 13.5 The resistance of an iron wire at  $0^\circ\text{C}$  is  $1 \times 10^4 \Omega$ . What is the resistance at  $500^\circ\text{C}$  if the temperature coefficient of resistance of iron is  $5.2 \times 10^{-3} \text{K}^{-1}$ ? (Ans:  $3.6 \times 10^4 \Omega$ )
- 13.6 Calculate terminal potential difference of each of cells in circuit of Fig. P.13.6.

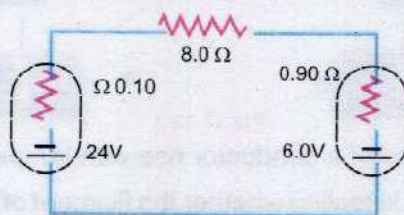


Fig.P. 13.6

(Ans: 23.8 V, 7.8 V)



- 13.7 Find the current which flows in all the resistances of the circuit of Fig. P.13.7.

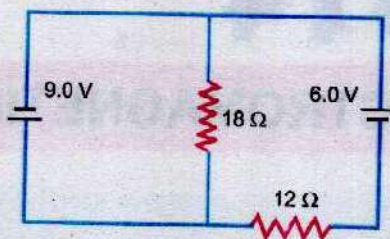


Fig. P. 13.7

(Ans: 1.25 A, 0.5 A)

- 13.8 Find the current and power dissipated in each resistance of the circuit, shown in Fig. P.13.8.

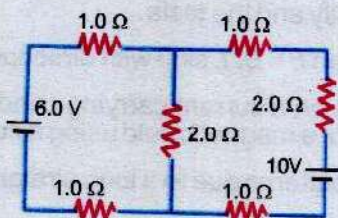


Fig.P. 13.8

(Ans: 0.8 A, 1.4 A, 2.2 A, 0.64 W, 1.96 W, 3.92 W, & 9.68 W)



**ELECTROMAGNETISM****Learning Objectives**

At the end of this chapter the students will be able to:

1. Appreciate that a force might act on a current carrying conductor placed in a magnetic field.
2. Define magnetic flux density and the tesla.
3. Derive and use the equation  $F = BIL \sin\theta$  with directions.
4. Understand how the force on a current carrying conductor can be used to measure the magnetic flux density of a magnetic field using a current balance.
5. Describe and sketch flux patterns due to a long straight wire.
6. Define magnetic flux and the weber.
7. Derive and use the relation  $\Phi = \mathbf{B} \cdot \mathbf{A}$ .
8. Understand and describe Ampere's law.
9. Appreciate the use of Ampere's law to find magnetic flux density inside a solenoid.
10. Appreciate that there acts a force on a charged particle when it moves in a uniform magnetic field and in electric field.
11. Describe the deflection of beams of charged particles moving in a uniform magnetic field.
12. Understand and describe method to measure  $e/m$ .
13. Know the basic principle of cathode ray oscilloscope and appreciate its use.
14. Derive the expression of torque due to couple acting on a coil.
15. Know the principle, construction and working of a galvanometer.
16. Know how a galvanometer is converted into a voltmeter and an ammeter.
17. Describe and appreciate the use of AVO meter/multimeter.
18. Read through analogue scale and digital display on electrical meters.

**E**lectric current generates magnetic field. At the same time, a changing magnetic field produces electric current. This interplay of electricity and magnetism is widely used in a number of electrical devices and appliances in modern age technology.



## 14.1 MAGNETIC FIELD DUE TO CURRENT IN A LONG STRAIGHT WIRE

Take a straight, thick copper wire and pass it vertically through a hole in a horizontal piece of cardboard. Place small compass needles on the cardboard along a circle with the centre at the wire. All the compass needles will point in the direction of N - S. Now pass a heavy current through the wire. It will be seen that the needles will rotate and will set themselves tangential to the circle (Fig. 14.1 a). On reversing the direction of current, the direction of needles is also reversed. As the current through the wire is stopped, all the needles again point along the N - S direction.

Following conclusions can be drawn from the above mentioned experiment:

- (i) A magnetic field is set up in the region surrounding a current carrying wire.
- (ii) The lines of force are circular and their direction depends upon the direction of current.
- (iii) The magnetic field lasts only as long as the current is flowing through the wire.

The direction of the lines of force can be found by a rule concluded directly from the above experiment which is stated as follows:

**If the wire is grasped in fist of right hand with the thumb pointing in the direction of the current, the fingers of the hand will circle the wire in the direction of the magnetic field.**

This is known as right hand rule and is illustrated in Fig. 14.1 (b).

## 14.2 FORCE ON A CURRENT CARRYING CONDUCTOR IN A UNIFORM MAGNETIC FIELD

We have seen that a current carrying conductor sets up its own magnetic field. If such a conductor is placed in an external magnetic field, the magnetic field of the conductor will interact with the external magnetic field, as a result of which the conductor may experience a force. To demonstrate

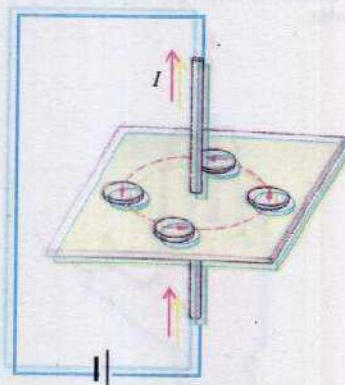


Fig. 14.1 (a)

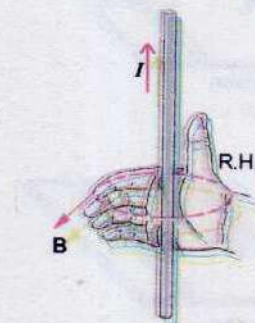


Fig. 14.1 (b)



### Do You Know?

If the middle finger of the right hand points in the direction of the magnetic field, the thumb in the direction of current, the force on the conductor will be normal to the palm towards the reader.

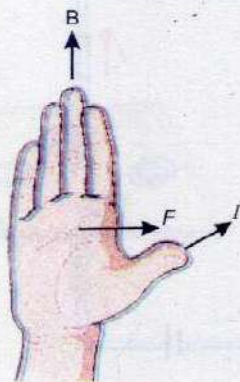
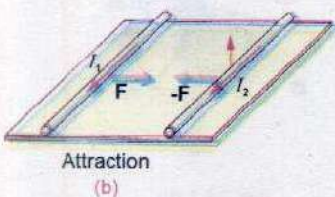
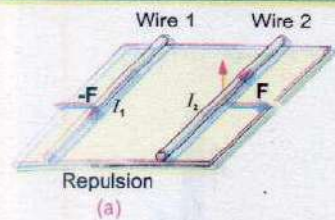


Fig. 14.3

### Do You Know?



(a) Two long parallel wires carrying currents  $I_1$  and  $I_2$  in opposite direction repel each other. (b) The wires attract each other when the currents are in the same direction.

this effect, consider a rod of copper, capable of moving on a pair of copper rails. The whole arrangement is placed in between the pole pieces of a horseshoe magnet so that the copper rod is subjected to a magnetic field directed vertically upwards (Fig. 14.2).

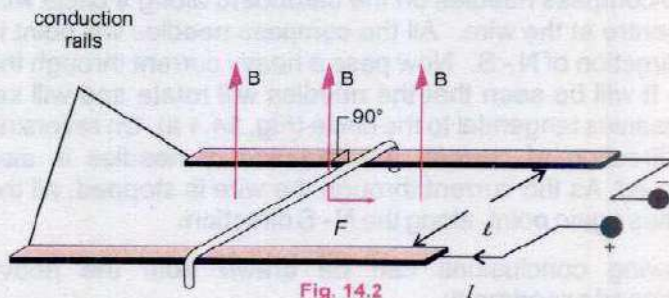


Fig. 14.2

When a current is passed through the copper rod from a battery, the rod moves on the rails. The relative directions of the current, magnetic field and the motion of the conductor are shown in Fig. 14.3. It can be seen that the force on a conductor is always at right angles to the plane which contains the rod and the direction of the magnetic field. The magnitude of the force depends upon the following factors:

- (i) The force  $F$  is directly proportional to  $\sin\alpha$  where  $\alpha$  is the angle between the conductor and the field. From this, it follows that the force is zero if the rod is placed parallel to the field and is maximum when the conductor is placed at right angles to the field.

$$F \propto \sin\alpha$$

- (ii) The force  $F$  is directly proportional to the current  $I$  flowing through the conductor. The more the current, greater is the force.

$$F \propto I$$

- (iii) The force  $F$  is directly proportional to the length  $L$  of the conductor inside the magnetic field.

$$F \propto L$$

- (iv) The force  $F$  is directly proportional to the strength of the applied magnetic field. The stronger the field, the greater is the force. If we represent the strength of the field by  $B$ , then

$$F \propto B$$

Combining all these factors,

$$F \propto ILB \sin\alpha$$



or  $F = kILB \sin\alpha$

where  $k$  is constant of proportionality. If we follow SI units, the value of  $k$  is 1. Thus in SI units

$$F = ILB \sin\alpha \quad \dots\dots\dots (14.1)$$

Eq.14.1 provides a definition for the strength of magnetic field. If  $I = 1 \text{ A}$ ,  $L = 1 \text{ m}$  and  $\alpha = 90^\circ$ , then  $F = B$ . Thus  $B$ , the strength of magnetic field which is also known as magnetic induction is defined as the force acting on one metre length of the conductor placed at right angle to the magnetic field when 1 A current is passing through it. In SI units the unit of  $B$  is tesla. A magnetic field is said to have a strength of one tesla if it exerts a force of one newton on one metre length of the conductor placed at right angles to the field when a current of one ampere passes through the conductor. Thus

$$1 \text{ T} = 1 \text{ N A}^{-1} \text{ m}^{-1}$$

It can be seen that the force on a current carrying conductor is given both in magnitude and direction by the following equation:

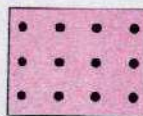
$$\mathbf{F} = I\mathbf{L} \times \mathbf{B} \quad \dots\dots\dots (14.2)$$

where the vector  $\mathbf{L}$  is in the direction of current flow. The magnitude of the vector  $I\mathbf{L} \times \mathbf{B}$  is  $ILB \sin\alpha$ , where  $\alpha$  is the angle between the vector  $\mathbf{L}$  and  $\mathbf{B}$ . This gives the magnitude of the force. The direction of the force  $\mathbf{F}$  (Fig. 14.3) is also correctly given by the right hand rule of the cross product of vectors of  $\mathbf{L}$  and  $\mathbf{B}$  i.e., rotate  $\mathbf{L}$  to coincide with  $\mathbf{B}$  through the smaller angle. Curl the fingers of right hand in the direction of rotation. The thumb points in the direction of force. In some situations the direction of the force is conveniently determined by applying the following rule:

Consider a straight current carrying conductor held at right angle to a magnetic field such that the current flows out of the plane of paper i.e., towards the reader as shown in Fig. 14.4. It is customary to represent a current flowing towards the reader by a symbol dot ( $\bullet$ ) and a current flowing away from him by a cross ( $\times$ ).

In order to find the direction of force, consider the lines of force (Fig. 14.4). The two fields tend to reinforce each other on left hand side of the conductor and cancel each other on the right side of it. The conductor tends to move towards the weaker part of the field i.e., the force on the conductor will be directed towards right in a direction at right angles to both the

**For Your Information**



Out of page



Into page

Convention to represent direction

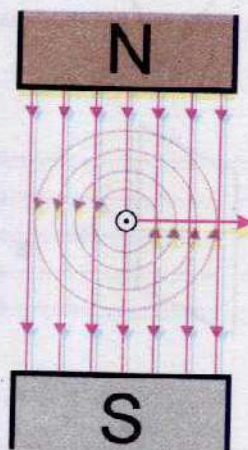


Fig. 14.4 The magnetic force on the current carrying conductor placed at right angle to a magnetic field.



conductor and the magnetic field. This rule is often referred as extension of right hand rule. It can be seen that the direction of the force is the same as given by the direction of the vector  $\mathbf{L} \times \mathbf{B}$ .

**Example 14.1:** A 20.0 cm wire carrying a current of 10.0 A is placed in a uniform magnetic field of 0.30 T. If the wire makes an angle of  $40^\circ$  with the direction of magnetic field, find the magnitude of the force acting on the wire.

**Solution:**

$$\text{Length of the wire} = L = 20.0 \text{ cm} = 0.20 \text{ m}$$

$$\text{Current} = I = 10.0 \text{ A}$$

$$\text{Strength of magnetic field} = B = 0.30 \text{ T}$$

$$\text{Angle} = \alpha = 40^\circ$$

Substituting these values in the equation

$$F = IBL \sin \alpha$$

$$F = 10.0 \text{ A} \times 0.30 \text{ T} \times 0.20 \text{ m} \times \sin 40^\circ = 0.39 \text{ N}$$

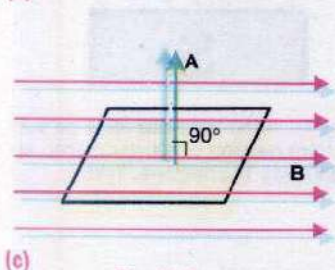
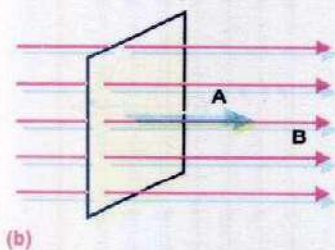
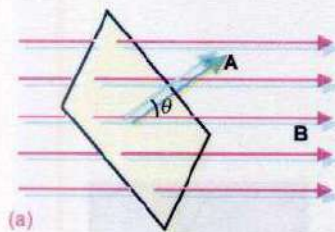


Fig. 14.5

### 14.3 MAGNETIC FLUX AND FLUX DENSITY

Like electric flux, the magnetic flux  $\Phi_B$  through a plane element of area  $\mathbf{A}$  in a uniform magnetic field  $\mathbf{B}$  is given by dot product of  $\mathbf{B}$  and  $\mathbf{A}$  (Fig. 14.5).

$$\Phi_B = \mathbf{B} \cdot \mathbf{A}$$

$$\Phi_B = BA \cos \theta \quad \dots \dots \dots (14.3)$$

Note that  $\mathbf{A}$  is a vector whose magnitude is the area of the element and whose direction is along the normal to the surface of the element,  $\theta$  is the angle between the directions of the vectors  $\mathbf{B}$  and  $\mathbf{A}$ .

In Fig. 14.5 (b) the field is directed along the normal to the area, so  $\theta$  is zero and the flux is maximum, equal to  $BA$ . When the field is parallel to the plane of the area (Fig. 14.5 c), the angle between the field and normal to area is  $90^\circ$  i.e.,  $\theta = 90^\circ$ , so the flux through the area in this position is zero.

In case of a curved surface placed in a non uniform magnetic field, the curved surface is divided into a number of small surface elements, each element being assumed plane and the flux through the whole curved surface is calculated by sum of the contributions from all the elements of the surface. From the definition of tesla, the unit of magnetic flux is  $\text{NmA}^{-1}$  which is called weber (Wb).



According to Eq. 14.3, the magnetic induction  $\mathbf{B}$  is the flux per unit area of a surface perpendicular to  $\mathbf{B}$ , hence it is also called as flux density. Its unit is then,  $\text{Wbm}^{-2}$ . Therefore, magnetic induction, i.e., the magnetic field strength is measured in terms of  $\text{Wbm}^{-2}$  or  $\text{NA}^{-1}\text{m}^{-1}$  (tesla).

**Example 14.2:** The magnetic field in a certain region is given by  $\mathbf{B} = (40\hat{i} - 18\hat{k}) \text{ Wbm}^{-2}$ . How much flux passes through a  $5.0 \text{ cm}^2$  area loop in this region if the loop lies flat in the  $xy$ - plane?

**Solution:**

$$\text{Magnetic induction} = \mathbf{B} = 40\hat{i} - 18\hat{k}$$

$$\text{Area of the loop} = \Delta\mathbf{A} = 5.0 \times 10^{-4} \text{ m}^2 \hat{k}$$

$$\text{Flux} = \Phi_B = \mathbf{B} \cdot \Delta\mathbf{A}$$

$$= (40\hat{i} - 18\hat{k}) \cdot (5.0 \times 10^{-4} \text{ m}^2 \hat{k})$$

$$\Phi_B = 90 \times 10^{-4} \text{ Wb}$$

#### 14.4 AMPERE'S LAW AND DETERMINATION OF FLUX DENSITY $\mathbf{B}$

We know that an electric current produces a magnetic field. Ampere, after carrying out a series of experiments, generalized his results into a law known as Ampere circuital law by which the magnetic flux density  $\mathbf{B}$  at any point due to a current carrying conductor can be easily computed as explained below:

Consider a closed path in the form a circle of radius  $r$  enclosing the current carrying wire (Fig. 14.6). This closed path is referred as Amperian path. Divide this path into small elements of length like  $\Delta\mathbf{L}$ . Let  $\mathbf{B}$  be the value of flux density at the site of  $\Delta\mathbf{L}$ . Determine the value of  $\mathbf{B} \cdot \Delta\mathbf{L}$ . If  $\theta$  is the angle between  $\mathbf{B}$  and  $\Delta\mathbf{L}$ , then

$$\mathbf{B} \cdot \Delta\mathbf{L} = B \Delta L \cos\theta$$

$B \cos\theta$  represents the component of  $\mathbf{B}$  along the element of length  $\Delta\mathbf{L}$  i.e., Component of  $\mathbf{B}$  parallel to  $\Delta\mathbf{L}$ . Thus  $\mathbf{B} \cdot \Delta\mathbf{L}$  represents the product of the length of the element  $\Delta\mathbf{L}$  and the component of  $\mathbf{B}$  parallel to  $\Delta\mathbf{L}$ . Ampere stated that the sum of the quantities  $\mathbf{B} \cdot \Delta\mathbf{L}$  for all path elements into which the complete loop has been divided equals  $\mu_0$  times the total current enclosed by the loop, where  $\mu_0$  is a constant, known

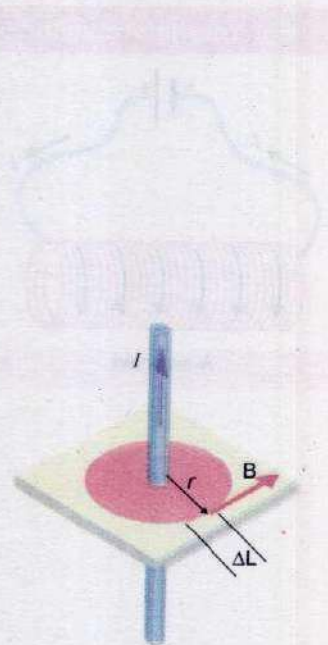


Fig. 14.6 Ampere's law to find the magnetic field in the vicinity of this long, straight, current-carrying wire.



as permeability of free space. In SI units its value is  $4\pi \times 10^{-7} \text{WbA}^{-1}\text{m}^{-1}$ . This can be mathematically expressed as

$$(\mathbf{B} \cdot \Delta\mathbf{L})_1 + (\mathbf{B} \cdot \Delta\mathbf{L})_2 + \dots + (\mathbf{B} \cdot \Delta\mathbf{L})_r + \dots + (\mathbf{B} \cdot \Delta\mathbf{L})_N = \mu_0 I$$

or 
$$\sum_{r=1}^N (\mathbf{B} \cdot \Delta\mathbf{L})_r = \mu_0 I \quad \dots \dots \dots (14.4)$$

where  $(\mathbf{B} \cdot \Delta\mathbf{L})_r$  is the value of  $\mathbf{B} \cdot \Delta\mathbf{L}$  along the  $r$ th element and  $N$  is the total number of elements into which the loop has been divided. This is known as Ampere's circuital law.

### Field Due to a Current Carrying Solenoid

A solenoid is a long, tightly wound, cylindrical coil of wire. When current passes through such a coil, it behaves like a bar magnet. The magnetic field produced by it is shown in Fig. 14.7(a). The field inside a long solenoid is uniform and much strong whereas out side the solenoid, it is so weak that it can be neglected as compared to the field inside.

The value of magnetic field  $\mathbf{B}$  can be easily determined by applying Ampere's circuital law. Consider a rectangular loop  $abcd$  as shown in Fig. 14.7 (b). Divide it into four elements of length  $ab = \ell_1$ ,  $bc = \ell_2$ ,  $cd = \ell_3$  and  $da = \ell_4$ .

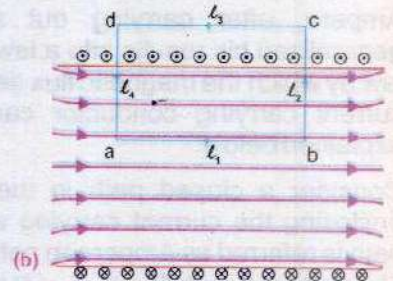
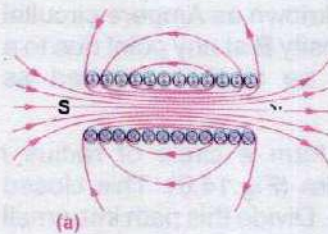
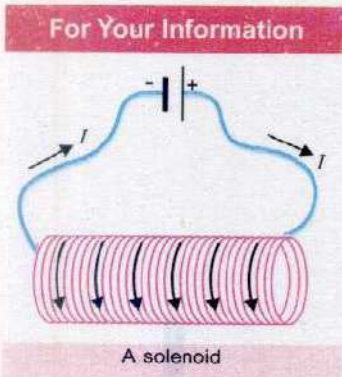


Fig. 14.7

Applying Ampere's law, we have

$$\sum_{r=1}^4 (\mathbf{B} \cdot \Delta\mathbf{L})_r = \mu_0 \times \text{current enclosed}$$

$$(\mathbf{B} \cdot \Delta\mathbf{L})_1 + (\mathbf{B} \cdot \Delta\mathbf{L})_2 + (\mathbf{B} \cdot \Delta\mathbf{L})_3 + (\mathbf{B} \cdot \Delta\mathbf{L})_4 = \mu_0 \times \text{current enclosed}$$

Now we will calculate the value of  $\mathbf{B} \cdot \Delta\mathbf{L}$  for each of the elements. First we will consider the element  $ab = \ell_1$  that lies inside the solenoid. Field inside the solenoid is uniform and is parallel to  $\ell_1$  (Fig. 14.7b), so



$$(\mathbf{B} \cdot \Delta\mathbf{L})_1 = \ell_1 B \cos 0^\circ$$

$$= \ell_1 B$$

For the element  $cd = \ell_3$ , that lies outside the solenoid, the field  $\mathbf{B}$  is zero, so

$$(\mathbf{B} \cdot \Delta\mathbf{L})_3 = 0$$

Again  $\mathbf{B}$  is perpendicular to  $\ell_2$  and  $\ell_4$  inside the solenoid and is zero outside, so

$$(\mathbf{B} \cdot \Delta\mathbf{L})_2 = (\mathbf{B} \cdot \Delta\mathbf{L})_4 = 0$$

$$\therefore \sum_{r=1}^4 (\mathbf{B} \cdot \Delta\mathbf{L})_r = B \ell_1 = \mu_0 \times \text{current enclosed}$$

To find the current enclosed, consider the rectangular surface bounded by the loop  $abcd$ .

If  $n$  is the number of turns per unit length of the solenoid, the rectangular surface will intercept  $n\ell_1$  turns, each carrying a current  $I$ . So the current enclosed by the loop is  $n\ell_1 I$ . Thus Ampere's law gives

$$B \ell_1 = \mu_0 \times n \ell_1 I$$

or 
$$B = \mu_0 n I \quad \dots \dots \dots (14.5)$$

The field  $\mathbf{B}$  is along the axis of the solenoid and its direction is given by right hand grip rule which states "hold the solenoid in the right hand with fingers curling in the direction of the current, the thumb will point in the direction of the field".

**Example 14.3:** A solenoid 15.0 cm long has 300 turns of wire. A current of 5.0 A flows through it. What is the magnitude of magnetic field inside the solenoid?

**Solution:**

Length of the solenoid =  $L = 15.0 \text{ cm} = 0.15 \text{ m}$

Total number of turns =  $N = 300$

Current =  $I = 5.0 \text{ A}$

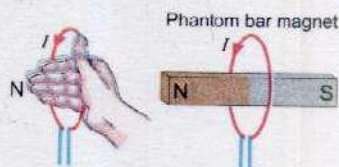
Permeability of free space =  $\mu_0 = 4\pi \times 10^{-7} \text{ WbA}^{-1}\text{m}^{-1}$

Number of turns per unit length =  $n = \frac{N}{\ell} = \frac{300}{0.15 \text{ m}}$

= 2000 turns/m

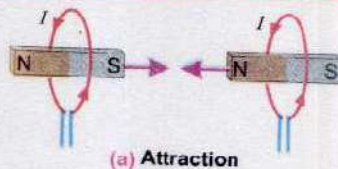
Magnetic field =  $B = \mu_0 n I$

### Do You Know?

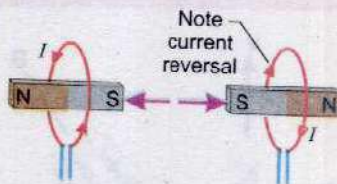


The current loop can be imagined to be a phantom bar magnet with a north pole and a south pole.

### For Your Information



(a) Attraction



(b) Repulsion

The "phantom" magnet included for each loop helps to explain the attraction and repulsion between the loops.



$$= 4 \times 10^{-7} \text{ WbA}^{-1}\text{m}^{-1} \times 2000 \text{ m}^{-1} \times 5.0 \text{ A}$$

$$B = 1.3 \times 10^{-2} \text{ Wbm}^{-2}$$

## 14.5 FORCE ON A MOVING CHARGE IN A MAGNETIC FIELD

We have seen that a current carrying conductor, when placed in a magnetic field, experiences a force. The current through the conductor is because of the motion of charges. Actually the magnetic field exerts force on these moving charges due to which the conductor experiences force. We are interested in calculating the force exerted on the moving charges.

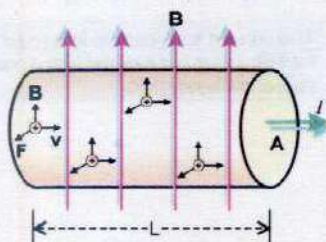


Fig. 14.8

Consider the situation as shown in Fig. 14.8 where we see a portion of the wire that is carrying a current  $I$ . Suppose there are  $n$  charge carriers per unit volume of the wire, and that each is moving with velocity  $v$  as shown. We will now find how long it takes for all the charge carriers originally in the wire segment shown to exit through the end area **A**.

The volume of the wire segment is  $AL$ . Because there are  $n$  charge carriers per unit volume, the number of charge carrier in the segment is  $nAL$ . If the charge on a charge carrier is  $q$ , each of it, as it crosses the end area, will transport a charge  $q$  through it. Assuming the speed of the carriers to be  $v$ , the carrier entering the left face of the segment takes a time  $\Delta t = L/v$  to reach the right hand face. During this time, all the charge carriers originally in the segment, namely  $nAL$ , will exit through the right hand face. As each charge carrier has a charge  $q$ , the charge  $\Delta Q$  that exits through the end area in time  $\Delta t = L/v$  is

$$\Delta Q = nALq$$

Then, from the definition of the current, the current  $I$  through the conductor is

$$I = \frac{\Delta Q}{\Delta t} = \frac{nALq}{L/v}$$

$$= nAqv \quad \dots \dots \dots (14.6)$$

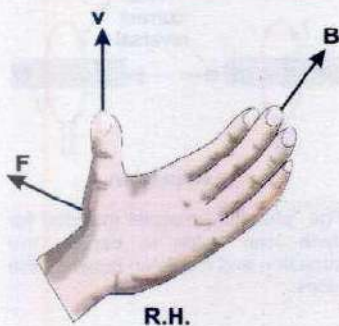
By Eq.14.2, the force on the segment  $L$  of a conductor, carrying current  $I$  is given by

$$F_L = IL \times B$$

Substituting the value of the current  $I$ ,

$$F_L = nAqvL \times B \quad \dots \dots \dots (14.7)$$

### For Your Information



The moving charge experiences a magnetic force  $F$  because of the magnetic field  $B$ .



In Fig.14.8, it can be seen that the direction of the segment  $L$  is the same as the direction of the velocity of the charge carriers. If  $\hat{L}$  is a unit vector along the direction of the segment  $L$  and  $\hat{v}$ , a unit vector along the velocity vector  $v$ , then  $\hat{L} = \hat{v}$

$$\begin{aligned} \therefore vL &= v\hat{L}L \\ &= v\hat{v}L = vL \end{aligned}$$

Substituting the value of  $vL$  in Eq.14.7, we have

$$\begin{aligned} F_L &= nAq(vL) \times B \\ &= nALqv \times B \end{aligned}$$

$nAL$  is the total number of charge carriers in the segment  $L$ , so the force experienced by a single charge carrier is

$$F = \frac{F_L}{nAL} = qv \times B$$

Thus the force experienced by a single charge carrier moving with velocity  $v$  in magnetic field of strength  $B$  is

$$F = q(v \times B) \quad \dots\dots\dots (14.8)$$

Although the Eq.14.8 has been derived with reference to charge carrier moving in a conductor but it does not involve any parameter of the conductor, so the Eq.14.8 is quite general and it holds for any charge carrier moving in a magnetic field.

If an electron is projected in a magnetic field with a velocity  $v$ , it will experience a force which is given by putting  $q = -e$  in Eq.14.8 where  $e$  is the magnitude of the electronic charge.

$$\therefore F = -e v \times B \quad \dots\dots\dots (14.9)$$

In case of proton,  $F$  is obtained by putting  $q = +e$ .

$$\therefore F = +e v \times B \quad \dots\dots\dots (14.10)$$

Note that in case of proton or a positive charge the direction of the force is given by the direction of the vector  $v \times B$  i.e., rotate  $v$  to coincide with  $B$  through the smaller angle of rotation and curl the fingers of right hand in the direction of rotation. Thumb will point in the direction of the force. This is illustrated in Fig.14.9 in which the proton enters into a magnetic field, as shown in figure, along the direction of dotted line. It experiences a force in the upward direction as given by the vector  $v \times B$ . As a result of this force the proton is deflected upwards as shown in Fig. 14.9. The direction of the force on a moving negative charge will be opposite to that of positive charge. Due to this force, the electron is deflected in the downward direction as it enters into a magnetic field. It

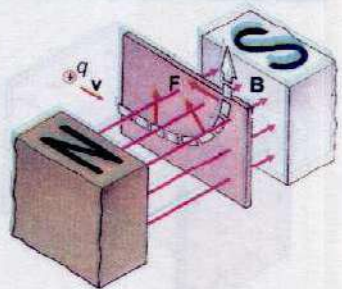


Fig. 14.9 Magnetic force  $F$  is perpendicular to both the magnetic field  $B$  and the velocity  $v$  and causes the particle's trajectory to bend in a vertical plane.



may be noted that the magnitude of the force on a moving charge carrier is  $qvB\sin\theta$  where  $\theta$  is the angle between the velocity of the carrier and the magnetic field. It is maximum when  $\theta = 90^\circ$  i.e., when the charged particle is projected at right angles to the field. It is zero when  $\theta = 0^\circ$  i.e., a charged particle projected in the direction of the field experiences no force.

## 14.6 MOTION OF CHARGED PARTICLE IN AN ELECTRIC AND MAGNETIC FIELD

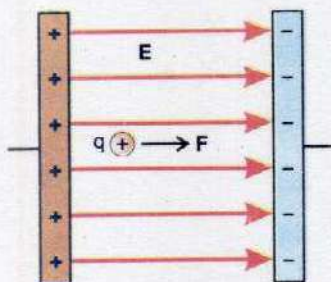


Fig. 14.10

When an electric charge  $q$  is placed in an electric field  $E$ , it experiences a force  $F$  parallel to electric field (Fig. 14.10). It is given by

$$F = qE$$

If the charge is free to move, then it will accelerate according to Newton's second law as

$$a = \frac{F}{m} = \frac{qE}{m} \quad \dots \dots \dots (14.11)$$

If electric field is uniform, then acceleration is also uniform and hence, the position of the particle at any instant of time can be found by using equations of uniformly accelerated motion.

When a charge particle  $q$  is moving with velocity  $v$  in a region where there is an electric field  $E$  and magnetic field  $B$ , the total force  $F$  is the vector sum of the electric force  $qE$  and magnetic force  $q(v \times B)$  that is,

$$F = F_e + F_b$$

$$F = qE + q(v \times B) \quad \dots \dots \dots (14.12)$$

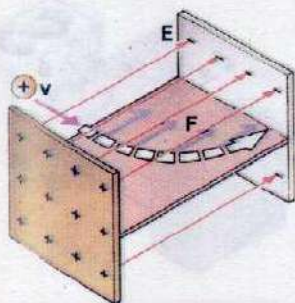
This force  $F$  is known as the Lorentz force. It is to be pointed out that only the electric force does work, while no work is done by the magnetic force which is simply a deflecting force.

## 14.7 DETERMINATION OF $e/m$ OF AN ELECTRON

Let a narrow beam of electrons moving with a constant speed  $v$  be projected at right angles to a known uniform magnetic field  $B$  directed into plane of paper. We have seen that electrons will experience a force

$$F = -e v \times B$$

### Do You Know?



The electric force  $F$  that acts on a positive charge is parallel to the electric field  $E$  and causes the particle's trajectory to bend in a horizontal plane.



The direction of the force will be perpendicular to both  $\mathbf{v}$  and  $\mathbf{B}$ . As the electron is experiencing a force that acts at right angle to its velocity, so it will change the direction of the velocity. The magnitude of velocity will remain unchanged. The magnitude of the force is  $e\mathbf{v}B\sin\theta$ . As  $\theta$  is  $90^\circ$ , so  $F = evB$ . As both  $v$  and  $B$  do not change, the magnitude of  $F$  is constant. Thus the electrons are subjected to a constant force  $evB$  at right angle to their direction of motion. Under the action of this force, the electrons will move along a circle as shown in Fig. 14.11.

The magnetic force  $F = Bev$  provides the necessary centripetal force  $\frac{mv^2}{r}$  to the electron of mass  $m$  to move along a circular trajectory of radius  $r$ . Thus we have

$$Bev = \frac{mv^2}{r}$$

or 
$$\frac{e}{m} = \frac{v}{Br} \quad \dots\dots\dots (14.13)$$

If  $v$  and  $r$  are known,  $e/m$  of the electron is determined. The radius  $r$  is measured by making the electronic trajectory visible. This is done by filling a glass tube with a gas such as hydrogen at low pressure. This tube is placed in a region occupied by a uniform magnetic field of known value. As electrons are shot into this tube, they begin to move along a circle under the action of magnetic force. As the electrons move, they collide with atoms of the gas. This excites the atoms due to which they emit light and their path becomes visible as a circular ring of light (Fig. 14.12). The diameter of the ring can be easily measured.

In order to measure the velocity  $v$  of the electrons, we should know the potential difference through which the electrons are accelerated before entering into the magnetic field. If  $V$  is this potential difference, the energy gained by electrons during their acceleration is  $Ve$ . This appears as the kinetic energy of electrons

$$\frac{1}{2}mv^2 = Ve$$

or 
$$v = \sqrt{\frac{2Ve}{m}}$$

Substituting the value of  $v$  in Eq. 14.13, we have

$$\frac{e}{m} = \frac{2V}{B^2r^2} \quad \dots\dots\dots (14.14)$$

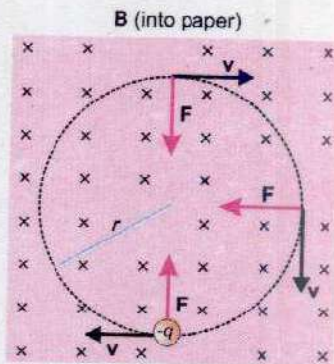


Fig 14.11 An electron is moving perpendicular to a constant magnetic field. The magnetic force  $F$  causes the particle to move on a circular path.



Fig. 14.12





**Example 14.4:** Find the radius of an orbit of an electron moving at a rate of  $2.0 \times 10^7 \text{ ms}^{-1}$  in a uniform magnetic field of  $1.20 \times 10^{-3} \text{ T}$ .

**Solution:**

Speed of the electron  $= v = 2.0 \times 10^7 \text{ ms}^{-1}$

Magnetic field strength  $= B = 1.20 \times 10^{-3} \text{ T}$

Mass of the electron  $= m = 9.11 \times 10^{-31} \text{ kg}$

Charge on electron  $= e = 1.61 \times 10^{-19} \text{ C}$

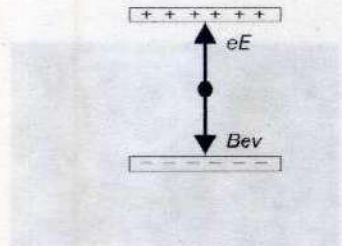
The radius of the orbit is

$$r = \frac{mv}{eB}$$

$$= \frac{9.11 \times 10^{-31} \text{ kg} \times 2.0 \times 10^7 \text{ ms}^{-1}}{1.61 \times 10^{-19} \text{ C} \times 1.20 \times 10^{-3} \text{ T}}$$

$$r = 9.43 \times 10^{-2} \text{ m}$$

**Example 14.5:** Alpha particles ranging in speed from  $1000 \text{ ms}^{-1}$  to  $2000 \text{ ms}^{-1}$  enter into a velocity selector where the electric intensity is  $300 \text{ Vm}^{-1}$  and the magnetic induction  $0.20 \text{ T}$ . Which particle will move undeviated through the field?



**Solution:**

$E = 300 \text{ Vm}^{-1} = 300 \text{ NC}^{-1}$        $B = 0.20 \text{ T}$

Only those particles will be able to pass through the plate for which the electric force  $eE$  acting on the particles balances the magnetic force  $Bev$  on the particle as shown in the figure.

Therefore  $eE = Bev$

Thus, the selected speed is

$$v = \frac{E}{B} = \frac{300 \text{ NC}^{-1}}{0.20 \text{ NA}^{-1}\text{m}^{-1}} = 1500 \text{ ms}^{-1}$$

The alpha particles having a speed of  $1500 \text{ ms}^{-1}$  will move undeviated through the field.

## 14.8 CATHODE RAY OSCILLOSCOPE

Cathode ray oscilloscope (CRO) is a very versatile electronic instrument which is, in fact, a high speed graph plotting device. It works by deflecting beam of electrons as they pass through uniform electric field between the two sets of parallel plates as shown in the Fig. 14.13(a). The deflected beam then falls on a fluorescent screen where it makes a visible spot.



F= Filament  
 C= Cathode  
 G= Grid  
 S= Fluorescent screen

$A_1, A_2, A_3$  = Anodes  
 X X = Horizontal deflection plates  
 Y Y = Vertical deflection plates

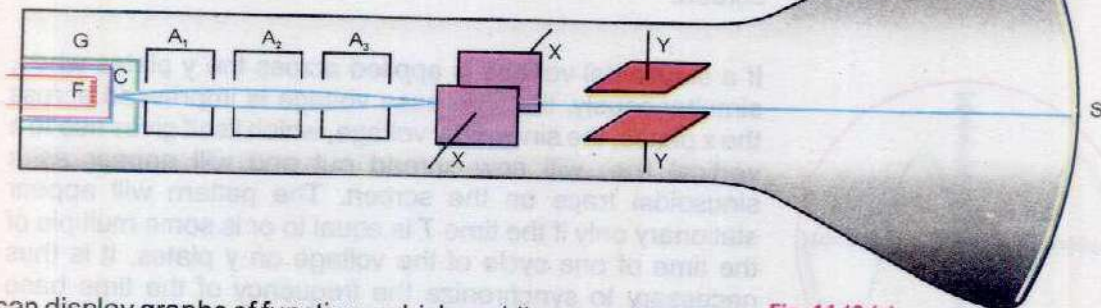


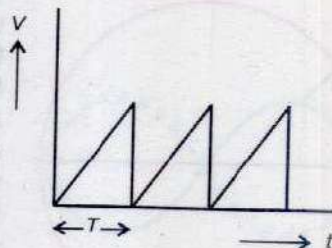
Fig. 14.13 (a)

It can display graphs of functions which rapidly vary with time. It is called cathode ray oscilloscope because it traces the desired waveform with a beam of electrons which are also called cathode rays.

The beam of the electrons is provided by an electron gun which consists of an indirectly heated cathode, a grid and three anodes. The filament F heats the cathode C which emits electrons. The anodes  $A_1, A_2, A_3$  which are at high positive potential with respect to cathode, accelerate as well as focus the electronic beam to fixed spot on the screen S. The grid G is at a negative potential with respect to cathode. It controls the number of electrons which are accelerated by anodes, and thus it controls the brightness of the spot formed on the screen.

Now we would explain how the waveform of various voltages is formed in CRO.

The two set of deflecting plates, shown in Fig. 14.13(a) are usually referred as x and y deflection plates because a voltage applied between the x plates deflects the beam horizontally on the screen i.e., parallel to x-axis. A voltage applied across the y plates deflects the beam vertically on the screen i.e., along the y-axis. The voltage that is applied across the x plates is usually provided by a circuit that is built in the CRO. It is known as sweep or time base generator. Its output waveform is a saw tooth voltage of period T (Fig. 14.13-b). The voltage increases linearly with time for a period T and then drops to zero. As this voltage is impressed across the x plates, the spot is deflected linearly with time along the x-axis for a time T. Then the spot returns to its starting point on the screen very quickly because a saw tooth voltage rapidly falls to its initial value at the end of each



Saw tooth voltage waveform

Fig. 14.13 (b)

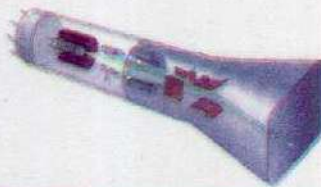
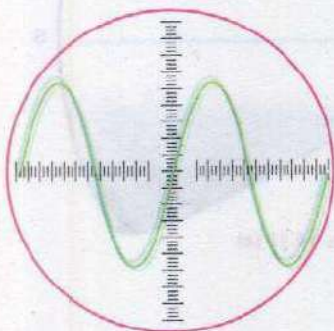


Fig. 14.13 (b)

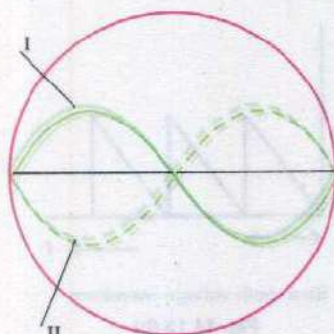
Three dimensional view of CRO



period. We can actually see the spot moving on the x-axis. If the time period  $T$  is very short, we see just a bright line on the screen.



(a)



(b)

Fig. 14.14

If a sinusoidal voltage is applied across the y plates when, simultaneously, the time base voltage is impressed across the x plates, the sinusoidal voltage, which itself gives rise to a vertical line, will now spread out and will appear as a sinusoidal trace on the screen. The pattern will appear stationary only if the time  $T$  is equal to or is some multiple of the time of one cycle of the voltage on y plates. It is thus necessary to synchronize the frequency of the time base generator with the frequency of the voltage at the y plates. This is possible by adjusting the synchronization controls provided on the front panel of the CRO.

### Uses of CRO

The CRO is used for displaying the waveform of a given voltage. Once the waveform is displayed, we can measure the voltage, its frequency and phase. For example, Fig. 14.14(a) shows the waveform of an alternating voltage. As the y-axis is calibrated in volts and the x-axis in time, we can easily find the instantaneous value and peak value of the voltage. The time period can also be determined by using the time calibration of x-axis. Information about the phase difference between two voltages can be obtained by simultaneously displaying their waveforms. For example, the waveforms of two voltages are shown in Fig. 14.14(b). These waveforms show that when the voltage of I is increasing, that of II is decreasing and vice versa. Thus the phase difference between these voltages is  $180^\circ$ .

## 14.9 TORQUE ON A CURRENT CARRYING COIL

Consider a rectangular coil carrying a current  $I$ . The coil is capable of rotation about an axis. Suppose it is placed in uniform magnetic field  $\mathbf{B}$  with its plane along the field (Fig. 14.15). We know that a current carrying conductor of length  $L$  when placed in a magnetic field experiences a force  $F = I L B \sin\theta$  where  $\theta$  is the angle between conductor and the field. In case of sides AB and CD of the coil, the angle  $\theta$  is zero or  $180^\circ$ , so the force on these sides will be zero. In case of sides DA and BC, the angle  $\theta$  is  $90^\circ$  and the force on these sides will be



$$F_1 = F_2 = ILB$$

where  $L$  is the length of these sides,  $F_1$  is the force on the side  $DA$  and  $F_2$  on  $BC$ . The direction of the force is given by the vector  $I \times \mathbf{B}$ . It can be seen that  $F_1$  is directed out of the plane of paper and  $F_2$  into the plane of paper (Fig. 14.15 a). Therefore, the forces  $F_1$  and  $F_2$  being equal and opposite form a couple which tends to rotate it about the axis. The torque of this couple is given by

$$\begin{aligned} \tau &= \text{Force} \times \text{Moment arm} \\ &= ILB \times a \end{aligned}$$

where  $a$  is the moment arm of the couple and is equal to the length of the side  $AB$  or  $CD$ .  $La$  is the area  $A$  of the coil,

$$\tau = IBA \quad \dots\dots\dots (14.15)$$

Note that the Eq.14.15 gives the value of torque when the field  $\mathbf{B}$  is in the plane of the coil. However if the field makes an angle  $\alpha$  with the plane of the coil, as shown in Fig 14.15(b), the moment arm now becomes a  $\cos\alpha$ . So

$$\tau = ILB \times a \cos\alpha$$

$$\text{or} \quad \tau = IBA \cos\alpha \quad \dots\dots\dots (14.16)$$

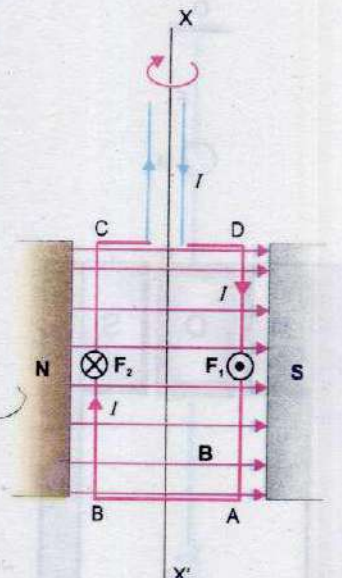
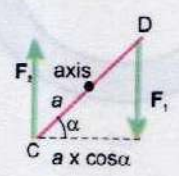


Fig 14.15 (a)



(Top view of coil)  
Fig 14.15 (b)

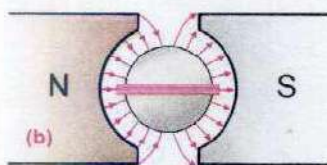
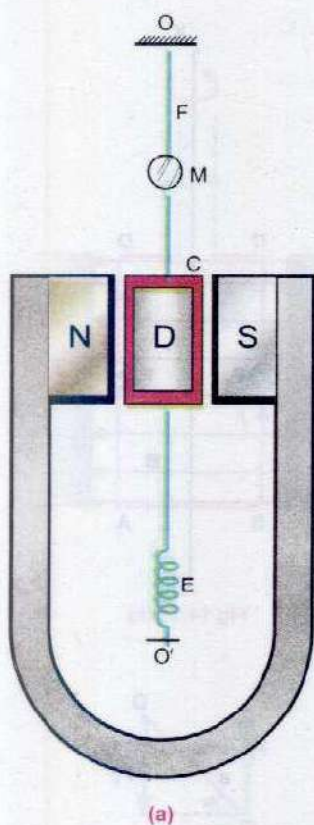
## 14.10 GALVANOMETER

A galvanometer is an electrical instrument used to detect the passage of current. Its working depends upon the fact that when a conductor is placed in a magnetic field, it experiences a force as soon as a current passes through it. Due to this force, a torque  $\tau$  acts upon the conductor if it is in the form of a coil or loop.

$$\tau = NIBA \cos\alpha$$

where  $N$  is the number of turns in the coil,  $A$  is its area,  $I$  is current passing through it,  $\mathbf{B}$  is the magnetic field in which the coil is placed such that its plane makes an angle  $\alpha$  with the direction of  $\mathbf{B}$ . Due to action of the torque, the coil rotates and





**Fig. 14.16** (a) Moving coil galvanometer (b) Concave pole piece and soft iron cylinder makes the field radial and stronger.

thus it detects the current. The construction of a moving coil galvanometer is shown in Fig. 14.16 (a).

A rectangular coil C is suspended between the concave shaped poles N and S of a U-shaped magnet with the help of a fine metallic suspension wire. The rectangular coil is made of enameled copper wire. It is wound on a frame of non-magnetic material. The suspension wire F is also used as one current lead to the coil. The other terminal of the coil is connected to a loosely wound spiral E which serves as the second current lead. A soft iron cylinder D is placed inside the coil to make the field radial and stronger near the coil as shown in Fig. 14.16 (b).

When a current is passed through the coil, it is acted upon by a couple which tends to rotate the coil. This couple is known as deflecting couple and is given by  $NIBA \cos \alpha$ . As the coil is placed in a radial magnetic field in which the plane of the coil is always parallel to the field (Fig. 14.16 b), so  $\alpha$  is always zero. This makes  $\cos \alpha = 1$  and thus,

$$\text{Deflecting couple} = NIBA$$

As the coil turns under the action of deflecting couple, the suspension wire Fig. (14.16 a) is twisted which gives rise to a torsional couple. It tends to untwist the suspension and restore the coil to its original position. This couple is known as restoring couple. The restoring couple of the suspension wire is proportional to the angle of deflection  $\theta$  as long as the suspension wire obeys Hooke's law. Thus

$$\text{Restoring torque} = c\theta$$

where the constant  $c$  of the suspension wire is known as torsional couple and is defined as couple for unit twist.

Under the effect of these two couples, coil comes to rest when

$$\text{Deflecting torque} = \text{Restoring torque}$$

$$NIBA = c\theta$$

or

$$I = \frac{c}{BAN} \theta \quad \dots \dots \dots (14.17)$$

Thus  $I \propto \theta$  since  $\frac{c}{BAN} = \text{Constant}$

Thus the current passing through the coil is directly proportional to the angle of deflection.



There are two methods commonly used for observing the angle of deflection of the coil. In sensitive galvanometers the angle of deflection is observed by means of small mirror attached to the coil along with a lamp and scale arrangement (Fig. 14.17). A beam of light from the lamp is directed towards the mirror of the galvanometer. After reflection from the mirror it produces a spot on a translucent scale placed at a distance of one metre from the galvanometer. When the coil rotates, the mirror attached to coil also rotates and spot of light moves along the scale. The displacement of the spot of light on the scale is proportional to the angle of deflection (provided the angle of deflection is small).

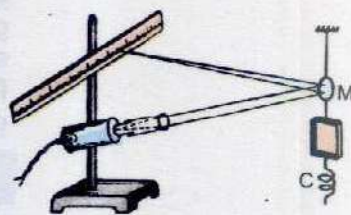


Fig. 14.17

The galvanometer used in school and college laboratories is a pivoted type galvanometer. In this type of galvanometer, the coil is pivoted between two jewelled bearings. The restoring torque is provided by two hair springs which also serve as current leads. A light aluminium pointer is attached to the coil which moves over a scale (Fig. 14.18). It gives the angle of deflection of the coil.

It is obvious from Eq. 14.17 that a galvanometer can be made more sensitive (to give large deflection for a given current) if  $c/BAN$  is made small. Thus, to increase sensitivity of a galvanometer,  $c$  may be decreased or  $B$ ,  $A$  and  $N$  may be increased. The couple  $c$  for unit twist of the suspension wire can be decreased by increasing its length and by decreasing its diameter. This process, however, cannot be taken too far, as the suspension must be strong enough to support the coil. Another method to increase the sensitivity of galvanometer is to increase  $N$ , the number of turns of the coil. In case of suspended coil type galvanometer, the number of turns can not be increased beyond a limit because it will make the coil heavy. To compensate for the loss of sensitivity, in case fewer turns are used in the coil, we increase the value of the magnetic field employed. We define current sensitivity of a galvanometer as the current, in microamperes, required to produce one millimetre deflection on a scale placed one metre away from the mirror of the galvanometer.

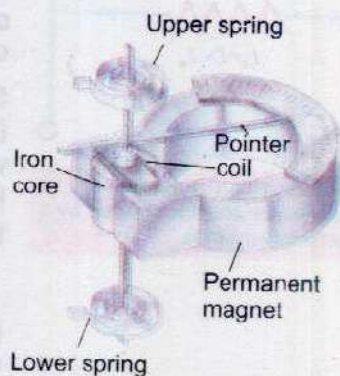


Fig. 14.18

When the current passing through the galvanometer is discontinued, the coil will not come to rest as soon as the current flowing through the coil is stopped. It keeps on oscillating about its mean position before coming to rest. In the same way if the current is established suddenly in a galvanometer, the coil will shoot beyond its final equilibrium position and will oscillate several times before coming to rest.



at its equilibrium position. As it is annoying and time consuming to wait for the coil to come to rest, artificial ways are employed to make the coil come to rest quickly. Such galvanometer in which the coil comes to rest quickly after the current passed through it or the current is stopped from flowing through it, is called stable or a dead beat galvanometer.

### Ammeter

An ammeter is an electrical instrument which is used to measure current in amperes. This is basically a galvanometer. The portion of the galvanometer whose motion causes the needle of the device to move across the scale is usually known as meter - movement. Most meter movements are very sensitive and full scale deflection is obtained with a current of few milliamperes only. So an ordinary galvanometer cannot be used for measuring large currents without proper modification.

Suppose we have a galvanometer whose meter - movement (coil) has a resistance  $R_g$  and which gives full scale deflection when current  $I_g$  is passed through it. From Ohm's law we know that the potential difference  $V_g$  which causes a current  $I_g$  to pass through the galvanometer is given by

$$V_g = I_g R_g$$

If we want to convert this galvanometer into an ammeter which can measure a maximum current  $I$ , it is necessary to connect a low value bypass resistor called shunt. The shunt resistance is of such a value so that the current  $I_g$  for full scale deflection of the galvanometer passes through the galvanometer and the remaining current  $(I - I_g)$  passes through the shunt in this situation (Fig. 14.19).

The shunt resistance  $R_s$  can be calculated from the fact that as the meter - movement and the shunt are connected in parallel with each other, the potential difference across the meter - movement is equal to the potential difference across the shunt.

$$\therefore I_g R_g = (I - I_g) R_s$$

$$\text{or } R_s = \frac{I_g}{I - I_g} R_g \quad \dots \dots \dots (14.18)$$

The resistance of the shunt is usually so small that a piece of

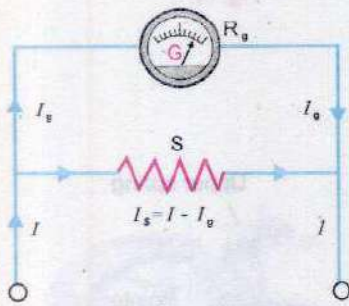


Fig. 14.19 An ammeter is a galvanometer which is shunted by a proper low resistance.



copper wire serves the purpose. The resistance of the ammeter is the combined resistance of the galvanometer's meter - movement and the shunt. Usually it is very small. An ammeter must have a very low resistance so that it does not disturb the circuit in which it is connected in series in order to measure the current.

### Voltmeter

A voltmeter is an electrical device which measures the potential difference in volts between two points. This, too, is made by modifying a galvanometer. Since a voltmeter is always connected in parallel, it must have a very high resistance so that it will not short the circuit across which the voltage is to be measured. This is achieved by connecting a very high resistance  $R_h$  placed in series with the meter - movement (Fig.14.20). Suppose we have a meter - movement whose resistance is  $R_g$  and which deflects full scale with a current  $I_g$ . In order to make a voltmeter from it which has a range of  $V$  volts, the value of the high resistance  $R_h$  should be such that full scale deflection will be obtained when it is connected across  $V$  volt. Under this condition the current through the meter - movement is  $I_g$ . Applying Ohm's law (Fig.14.20) we have

$$V = I_g (R_g + R_h)$$

$$R_h = \frac{V}{I_g} - R_g \quad \dots\dots\dots (14.19)$$

If the scale of the galvanometer is calibrated from 0 to  $V$  volts, the combination of galvanometer and the series resistor acts as a voltmeter with range 0 -  $V$  volts. By properly arranging the resistance  $R_h$ , any voltage can be measured. Thus, we see that a voltmeter possesses high resistance.

It may be noted that a voltmeter is always connected across the two points between which potential difference is to be measured. Before connecting a voltmeter, it should be assured that its resistance is very high in comparison with the resistance of the circuit across which it is connected otherwise it will load the circuit and will alter the potential difference which is required to be measured.

**Example 14.6:** What shunt resistance must be connected across a galvanometer of  $50.0 \Omega$  resistance which gives full scale deflection with  $2.0 \text{ mA}$  current, so as to convert it into an ammeter of range  $10.0 \text{ A}$ ?

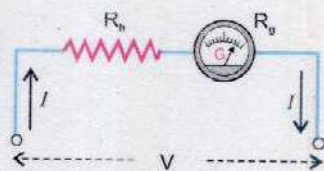


Fig. 14.20 A galvanometer in series with a high resistance acts as a voltmeter.



### Solution:

Resistance of galvanometer =  $R_g = 50.0 \Omega$

Current for full scale deflection =  $I_g = 2.0 \text{ mA}$

Current to be measured =  $I = 10.0 \text{ A}$

The shunt resistance  $R_s$  is given by

$$R_s = \frac{I_g}{I - I_g} R_g = \frac{2.0 \times 10^{-3} \text{ A}}{10.0 \text{ A} - 2.0 \times 10^{-3} \text{ A}} \times 50.0 \text{ A} = 0.01 \Omega$$

### Ohmmeter

It is a useful device for rapid measurement of resistance. It consists of a galvanometer, and adjustable resistance  $r_s$  and a cell connected in series (Fig.14.21-a). The series resistance  $r_s$  is so adjusted that when terminals c and d are short circuited, i.e., when  $R = 0$ , the galvanometer gives full scale deflection. So the extreme graduation of the usual scale of the galvanometer is marked 0 for resistance measurement. When terminals c and d are not joined, no current passes through the galvanometer and its deflection is zero. Thus zero of the scale is marked as infinity (Fig. 14.21-b). Now a known resistance  $R$  is connected across the terminals c and d. The galvanometer deflects to some intermediate point. This point is calibrated as  $R$ . In this way the whole scale is calibrated into resistance. The resistance to be measured is connected across the terminals c and d. The deflection on the calibrated scale reads the value of the resistance directly.

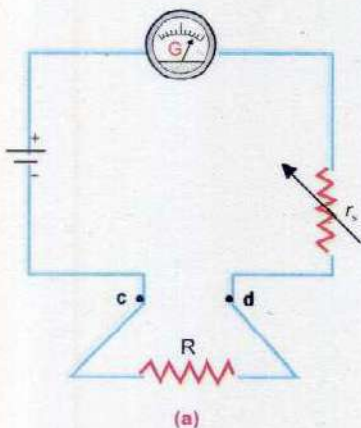


Fig. 14.21 A moving coil galvanometer is converted into an ohmmeter.

### 14.11 AVO METER - MULTIMETER

It is an instrument which can measure current in amperes, potential difference in volts and resistance in ohms. It basically consists of a sensitive moving coil galvanometer which is converted into a multirange ammeter, voltmeter or ohmmeter accordingly as a current measuring



circuit or a voltage measuring circuit or a resistance measuring circuit is connected with the galvanometer with the help of a switch known as function switch (Fig. 14.22). Here X, Y are the main terminals of the AVO meter which are connected with the circuit in which measurement is required. FS is the function selector switch which connects the galvanometer with relevant measuring circuit.

### Voltage Measuring Part of AVO Meter

The voltage measuring part of the AVO meter is actually a multirange voltmeter. It consists of a number of resistances each of which can be connected in series with the moving coil galvanometer with the help of a switch called the range switch (Fig. 14.23). The value of each resistance depends upon the range of the voltmeter which it controls.

Alternating voltages are also measured by AVO meter. AC voltage is first converted into DC voltage by using diode as rectifier and then measured as usual.

### Current Measuring Part of AVO Meter

The current measuring part of the AVO meter is actually a multirange ammeter. It consists of a number of low resistances connected in parallel with the galvanometer. The values of these resistances depend upon the range of the ammeter (Fig. 14.24).

The circuit also has a range selection switch RS which is used to select a particular range of the current.

### Resistance Measuring Part of AVO Meter

The resistance measuring part of AVO meter is, in fact, a multirange ohmmeter. Circuit for each range of this meter consists of a battery of emf  $V_0$  and a variable resistance  $r_s$  connected in series with galvanometer of resistance  $R_g$ . When the function switch is switched to position  $X_3$  (Fig. 14.22), this circuit is connected with the terminals X, Y of the AVO meter (Fig. 14.25 a).

Before measuring an unknown resistance by an ohmmeter it is first zeroed which means that we short circuit the terminals X, Y and adjust  $r_s$  to produce full scale deflection.

### Digital Multimeter (DMM)

Another useful device to measure resistance, current and voltage is an electronic instrument called digital multimeter.

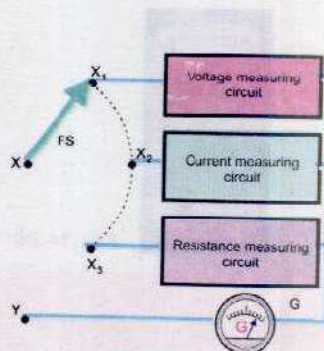


Fig. 14.22

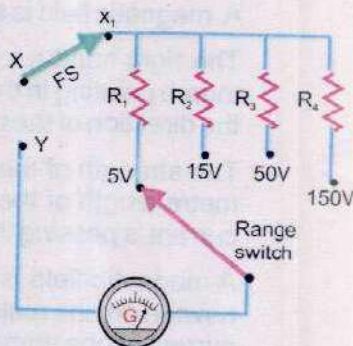


Fig. 14.23

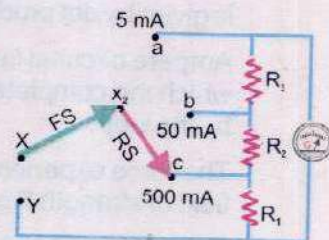


Fig. 14.24

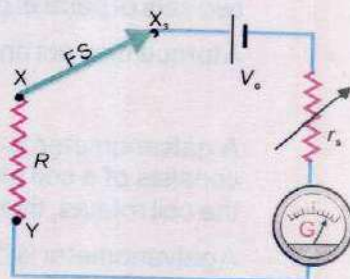


Fig. 14.25





Fig.14.26

It is a digital version of an AVO meter. It has become a very popular testing device because the digital values are displayed automatically with decimal point, polarity and the unit for V, A or  $\Omega$ . These meters are generally easier to use because they eliminate the human error that often occurs in reading the dial of an ordinary AVO meter. A portable DMM is shown in Fig. 14.26.

## SUMMARY

- A magnetic field is set up in the region surrounding a current carrying conductor.
- The right hand rule states, "If the wire is grasped in the fist of right hand with the thumb pointing in the direction of current, the fingers of the hand will circle the wire in the direction of the magnetic field".
- The strength of the magnetic field or magnetic induction is the force acting on one metre length of the conductor placed at right angle to the magnetic field when 1 A current is passing through it.
- A magnetic field is said to have a strength of one tesla if it exerts a force of one newton on one metre length of the conductor placed at right angle to the field when a current of one ampere passes through the conductor.
- The magnetic flux  $\Phi_B$  through plane element of area  $\mathbf{A}$  in a uniform magnetic field  $\mathbf{B}$  is given by dot product of  $\mathbf{B}$  and  $\mathbf{A}$ .
- Ampere circuital law states the sum of the quantities  $\mathbf{B} \cdot \Delta\mathbf{L}$  for all path elements into which the complete loop has been divided equals  $\mu_0$  times the total current enclosed by the loop.
- The force experienced by a single charge carrier moving with velocity  $\mathbf{v}$  in magnetic field of strength  $\mathbf{B}$  is  $\mathbf{F} = q(\mathbf{v} \times \mathbf{B})$ .
- Cathode ray oscilloscope (CRO) is a high speed graph plotting device. It works by deflecting beam of electrons as they pass through uniform electric field between the two sets of parallel plates.
- A torque may act on a current carrying coil placed in a magnetic field.
 
$$\tau = IAB \cos \alpha$$
- A galvanometer is an electric device which detects the flow of current. It usually consists of a coil placed in a magnetic field. As the current passes through the coil, the coil rotates, thus indicating the flow of current.
- A galvanometer is converted into an ammeter by properly shunting it.
- A galvanometer is converted into a voltmeter by connecting a high resistance in series.



## QUESTIONS

- 14.1 A plane conducting loop is located in a uniform magnetic field that is directed along the x-axis. For what orientation of the loop is the flux a maximum? For what orientation is the flux a minimum?
- 14.2 A current in a conductor produces a magnetic field, which can be calculated using Ampere's law. Since current is defined as the rate of flow of charge, what can you conclude about the magnetic field due to stationary charges? What about moving charges?
- 14.3 Describe the change in the magnetic field inside a solenoid carrying a steady current  $I$ , if (a) the length of the solenoid is doubled but the number of turns remains the same and (b) the number of turns is doubled, but the length remains the same.
- 14.4 At a given instant, a proton moves in the positive x direction in a region where there is magnetic field in the negative z direction. What is the direction of the magnetic force? Will the proton continue to move in the positive x direction? Explain.
- 14.5 Two charged particles are projected into a region where there is a magnetic field perpendicular to their velocities. If the charges are deflected in opposite directions, what can you say about them?
- 14.6 Suppose that a charge  $q$  is moving in a uniform magnetic field with a velocity  $v$ . Why is there no work done by the magnetic force that acts on the charge  $q$ ?
- 14.7 If a charged particle moves in a straight line through some region of space, can you say that the magnetic field in the region is zero?
- 14.8 Why does the picture on a TV screen become distorted when a magnet is brought near the screen?
- 14.9 Is it possible to orient a current loop in a uniform magnetic field such that the loop will not tend to rotate? Explain.
- 14.10 How can a current loop be used to determine the presence of a magnetic field in a given region of space?
- 14.11 How can you use a magnetic field to separate isotopes of chemical element?
- 14.12 What should be the orientation of a current carrying coil in a magnetic field so that torque acting upon the coil is (a) maximum (b) minimum?
- 14.13 A loop of wire is suspended between the poles of a magnet with its plane parallel to the pole faces. What happens if a direct current is put through the coil? What happens if an alternating current is used instead?
- 14.14 Why the resistance of an ammeter should be very low?
- 14.15 Why the voltmeter should have a very high resistance?



## PROBLEMS

- 14.1 Find the value of the magnetic field that will cause a maximum force of  $7.0 \times 10^{-3}$  N on a 20.0 cm straight wire carrying a current of 10.0 A. (Ans:  $3.5 \times 10^{-3}$  T)
- 14.2 How fast must a proton move in a magnetic field of  $2.50 \times 10^{-3}$  T such that the magnetic force is equal to its weight? (Ans:  $4.09 \times 10^{-5}$  ms<sup>-1</sup>)
- 14.3 A velocity selector has a magnetic field of 0.30 T. If a perpendicular electric field of 10,000 Vm<sup>-1</sup> is applied, what will be the speed of the particle that will pass through the selector? (Ans:  $3.3 \times 10^4$  ms<sup>-1</sup>)
- 14.4 A coil of 0.1 m x 0.1 m and of 200 turns carrying a current of 1.0 mA is placed in a uniform magnetic field of 0.1 T. Calculate the maximum torque that acts on the coil. (Ans:  $2.0 \times 10^{-4}$  Nm)
- 14.5 A power line 10.0 m high carries a current 200 A. Find the magnetic field of the wire at the ground. (Ans:  $4.0 \times 10^{-6}$  T)
- 14.6 You are asked to design a solenoid that will give a magnetic field of 0.10 T, yet the current must not exceed 10.0 A. Find the number of turns per unit length that the solenoid should have. (Ans:  $7.96 \times 10^3$ )
- 14.7 What current should pass through a solenoid that is 0.5 m long with 10,000 turns of copper wire so that it will have a magnetic field of 0.4 T? (Ans: 16.0 A)
- 14.8 A galvanometer having an internal resistance  $R_g = 15.0 \Omega$  gives full scale deflection with current  $I_g = 20.0$  mA. It is to be converted into an ammeter of range 10.0 A. Find the value of shunt resistance  $R_s$ . (Ans:  $0.030 \Omega$ )
- 14.9 The resistance of a galvanometer is  $50.0 \Omega$  and reads full scale deflection with a current of 2.0 mA. Show by a diagram how to convert this galvanometer into voltmeter reading 200 V full scale. (Ans:  $R_v = 99950 \Omega$ )
- 14.10 The resistance of a galvanometer coil is  $10.0 \Omega$  and reads full scale with a current of 1.0 mA. What should be the values of resistances  $R_1$ ,  $R_2$  and  $R_3$  to convert this galvanometer into a multirange ammeter of 100, 10.0 and 1.0 A as shown in the Fig.P.14.10? (Ans:  $R_1 = .0001 \Omega$ ,  $R_2 = 0.001 \Omega$ ,  $R_3 = 0.01 \Omega$ )



# Chapter 15

## ELECTROMAGNETIC INDUCTION

### Learning Objectives

At the end of this chapter the students will be able to:

1. Recall that a changing magnetic flux through a circuit causes an emf to be induced in the circuit.
2. Know that the induced emf lasts so long as the magnetic flux keeps changing.
3. Determine Motional emf.
4. Use Faraday's law of electromagnetic induction to determine the magnitude of induced emf.
5. Apply Lenz's law to determine the direction of induced emf.
6. Recognize self and mutual induction.
7. Define mutual inductance, self-inductance and its unit henry.
8. Know and use the formula  $E = \frac{1}{2} L I^2$
9. Calculate the energy stored in an inductance.
10. Describe the principle, construction and operation of an AC and DC generator.
11. Describe the principle, construction and operation of DC motor.
12. Recognize back emf in motors and back motor effect in generators.
13. Describe the structure and principle of operation of transformer.
14. Use  $\frac{N_s}{N_p} = \frac{V_s}{V_p}$  and  $V_p I_p = V_s I_s$  for an ideal transformer.
15. Apply transformer equation to solve the problems.
16. Understand and describe eddy currents and use of laminated core.

**A**s soon as Oersted discovered that electric currents produce magnetic fields, many scientists began to look for the reverse effect, that is, to cause an electric current by means of a magnetic field. In 1831 Michael Faraday in England and at the same time Joseph Henry in USA observed that an emf is set up in a conductor when it moves across a magnetic field. If the moving conductor was connected to a sensitive galvanometer, it would show an electric current flowing through the circuit as long as the conductor is kept moving in the magnetic field. The emf produced in the conductor is called induced emf, and the current generated is called the induced current. This phenomenon is known as electromagnetic induction.



## 15.1 INDUCED EMF AND INDUCED CURRENT

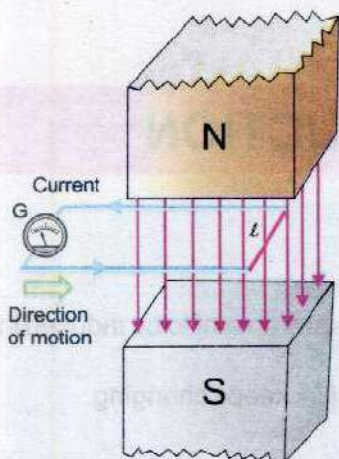


Fig.15.1

There are many ways to produce induced emf. Fig. 15.1 illustrates one of them. Consider a straight piece of wire of length  $l$  placed in the magnetic field of a permanent magnet. The wire is connected to a sensitive galvanometer. This forms a closed path or loop without any battery. In the beginning when the loop is at rest in the magnetic field, no current is shown by the galvanometer. If we move the loop from left to right, the length  $l$  of the wire is dragged across the magnetic field and a current flows through the loop. As we stop moving the loop, current also stops. Now, if we move the loop in opposite direction, current also reverses its direction. This is indicated by the deflection of the galvanometer in opposite direction.

The induced current depends upon the speed with which conductor moves and upon the resistance of the loop. If we change the resistance of the loop by inserting different resistors in the loop, and move it in the magnetic field with the same speed every time, we find that the product of induced current  $I$  and the resistance  $R$  of the loop remains constant, i.e.,

$$I \times R = \text{constant}$$

This constant is the induced emf. The induced emf leads to an induced current when the circuit is closed. The current can be increased by

- i) using a stronger magnetic field
- ii) moving the loop faster
- iii) replacing the loop by a coil of many turns

If we perform the above experiment in the other way, i.e., instead of moving the loop across the magnetic field, we keep the loop stationary and move the magnet, then it can be easily observed that the results are the same. Thus, it can be concluded that it is the relative motion of the loop and the magnet that causes the induced emf.

In fact, this relative motion changes the magnetic flux through the loop, therefore, we can say that an induced emf is produced in a loop if the magnetic flux through it changes. The greater the rate of change of flux, the larger is the induced emf.

There are some other methods described below in which an emf is induced in a loop by producing a change of magnetic



flux through it.

1. Fig. 15.2 (a) shows a bar magnet and a coil of wire to which a galvanometer is connected. When there is no relative motion between the magnet and the coil, the galvanometer indicates no current in the circuit. As soon as the bar magnet is moved towards the coil, a current appears in it (Fig 15.2 b). As the magnet is moved, the magnetic flux through the coil changes, and this changing flux produces the induced current in the coil. When the magnet moves away from the coil, a current is again induced but now in opposite direction. The current would also be induced if the magnets were held stationary and the coil is moved.

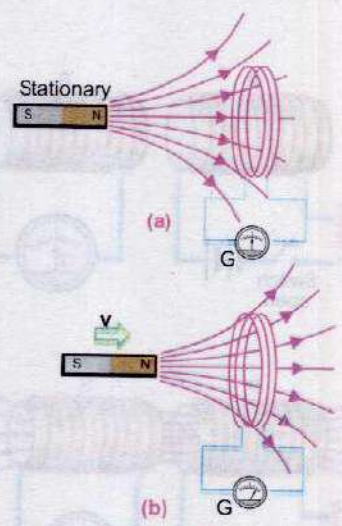


Fig. 15.2

2. There is another method in which the current is induced in a coil by changing the area of the coil in a constant magnetic field. Fig. 15.3 (a) shows that no current is induced in the coil of constant area placed in a constant magnetic field. However, when the coil is being distorted so as to reduce its area, (Fig. 15.3 b) an induced emf and hence current appears. The current vanishes when the area is no longer changing. If the distorted coil is brought to its original circular shape thereby increasing the area, an oppositely directed current is induced which lasts as long as the area is changing.

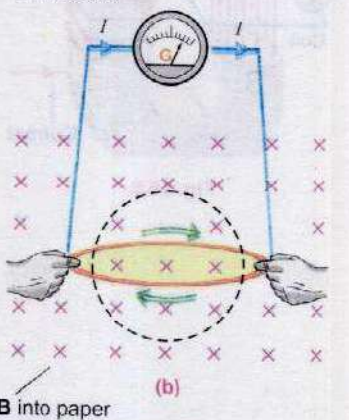
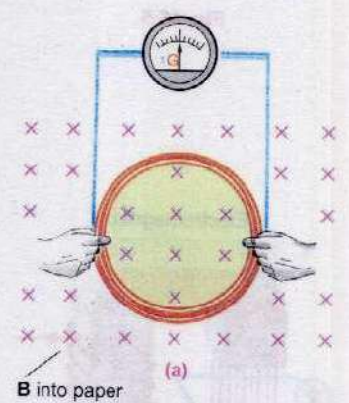


Fig. 15.3

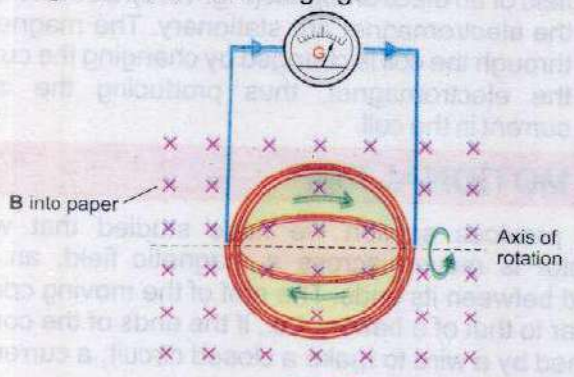


Fig. 15.4

3. An induced current can also be generated when a coil of constant area is rotated in a constant magnetic field. Here, also, the magnetic flux through the coil changes (Fig. 15.4). This is the basic principle used in electric generators.
4. A very interesting method to induce current in a coil involves by producing a change of magnetic flux in



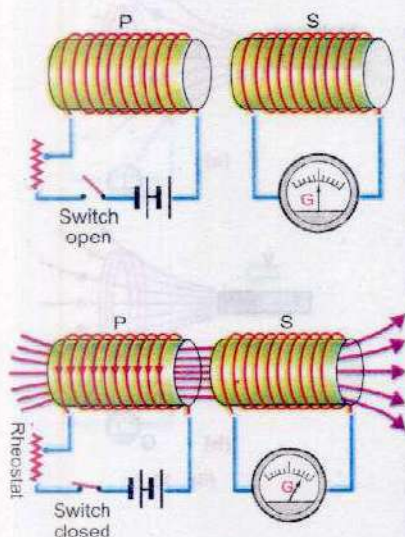


Fig. 15.5

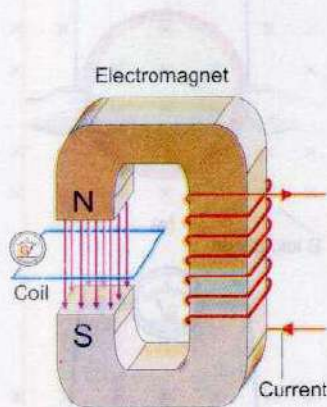


Fig. 15.6

a nearby coil. Fig. 15.5 shows two coils placed side by side. The coil P is connected in series with a battery, a rheostat and a switch, while the other coil S is connected to a galvanometer only. Since there is no battery in the coil S, one might expect that the current through it will always be zero. Now, if the switch of the coil P is suddenly closed, a momentary current is induced in coil S. This is indicated by the galvanometer, which suddenly deflects and then returns to zero. No induced current exists in coil S as long as the current flows steadily in the coil P. An oppositely directed current is induced in the coil S at the instant the switch of coil P is opened. Actually, the current in P grows from zero to its maximum value just after the switch is closed. The current comes down to zero when the switch is opened. Due to change in current, the magnetic flux associated with the coil P changes momentarily. This changing flux is also linked with the coil S that causes the induced current in it. Current in coil P can also be changed with the help of rheostat.

- It is also possible to link the changing magnetic flux with a coil by using an electromagnet instead of a permanent magnet. The coil is placed in the magnetic field of an electromagnet (Fig. 15.6). Both the coil and the electromagnet are stationary. The magnetic flux through the coil is changed by changing the current of the electromagnet, thus producing the induced current in the coil.

## 15.2 MOTIONAL EMF

In the previous section we have studied that when a conductor is moved across a magnetic field, an emf is induced between its ends. The emf of the moving conductor is similar to that of a battery, i.e., if the ends of the conductor are joined by a wire to make a closed circuit, a current flows through it.

**The emf induced by the motion of a conductor across a magnetic field is called motional emf.**

Consider a conducting rod of length  $L$  placed on two parallel metal rails separated by a distance  $L$ . A galvanometer is connected between the ends c and d of the rails. This forms a complete conducting loop abcd (Fig. 15.7a). A uniform



magnetic field  $\mathbf{B}$  is applied directed into the page. Initially when the rod is stationary, galvanometer indicates no current in the loop. If the rod is pulled to the right with constant velocity  $\mathbf{v}$ , the galvanometer indicates a current flowing through the loop. Obviously, the current is induced due to the motion of the conducting rod across the magnetic field. The moving rod is acting as a source of emf  $\varepsilon = V_b - V_a = \Delta V$ .

When the rod moves, a charge  $q$  within the rod also moves with the same velocity  $\mathbf{v}$  in the magnetic field  $\mathbf{B}$  and experiences a force given by

$$\mathbf{F} = q\mathbf{v} \times \mathbf{B}$$

The magnitude of the force is

$$F = qvB \sin \theta$$

Since angle  $\theta$  between  $\mathbf{v}$  and  $\mathbf{B}$  is  $90^\circ$ , so

$$F = qvB$$

Applying the right hand rule, we see that  $\mathbf{F}$  is directed from a to b in the rod. As a result the charge migrates to the top end of the conductor. As more and more of the charges migrate, concentration of the charge is produced at the top b and deficiency of charges at the bottom a. This redistribution of charge sets up an electrostatic field  $\mathbf{E}$  directed from b to a. The electrostatic force on the charge is  $F_e = q\mathbf{E}$  directed from b to a. The system quickly reaches an equilibrium state in which these two forces on the charge are balanced. If  $E$  is the electric intensity in this state then

$$qE_0 = qvB$$

$$E_0 = vB \quad \dots \dots \dots (15.1)$$

The motional emf  $\varepsilon$  will be equal to the potential difference  $\Delta V = V_b - V_a$  between the two ends of the moving conductor in this equilibrium state. The gradient of potential will be given by  $\Delta V/L$ . As the electric intensity is given by the negative of the gradient therefore,

$$E_0 = -\frac{\Delta V}{L} \quad \dots \dots \dots (15.2)$$

$$\text{or } \Delta V = -LE_0 = -(LvB)$$

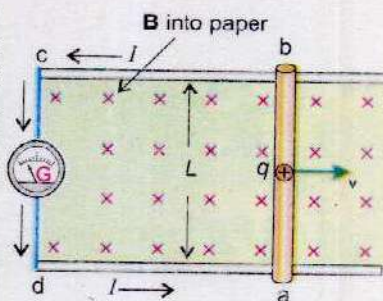
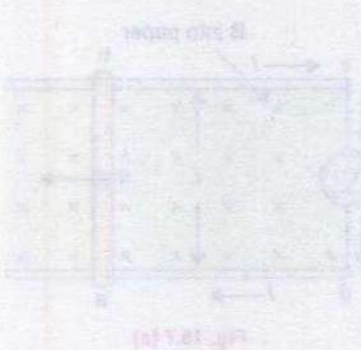


Fig. 15.7 (a)





The motional emf

$$\epsilon = \Delta v = -LvB \quad \dots\dots\dots (15.3)$$

This is the magnitude of motional emf. However, if the angle between  $\mathbf{v}$  and  $\mathbf{B}$  is  $\theta$ , then

$$\epsilon = -vBL \sin\theta \quad \dots\dots\dots (15.4)$$

Due to induced emf positive charges would flow along the path abcd, therefore the induced current is anticlockwise in the diagram. As the current flows the quantity of the charge at the top decreases so the electric intensity decreases but the magnetic force remains the same. Hence the equilibrium is disturbed in favour of magnetic force. Thus as the charges reach the end a of the conductor due to current flow, they are carried to the top end b of the conductor by the unbalanced magnetic field and the current continues to flow.

**Interesting Information**



This heater operates on the principle of electromagnetic induction. The water in the metal pot is boiling whereas that in the glass pot is not. Even the glass top of the heater is cool to touch. The coil just beneath the top comes ac that produces changing magnetic flux. Flux linking with pots induce emf in them. Current is generated in the metal pot that heats up the water, but no current flows through the glass pan, why?

**Example 15.1:** A metal rod of length 25 cm is moving at a speed of  $0.5 \text{ ms}^{-1}$  in a direction perpendicular to a  $0.25 \text{ T}$  magnetic field. Find the emf produced in the rod.

**Solution:**

Speed of rod =  $v = 0.5 \text{ ms}^{-1}$

Length of rod =  $L = 25 \text{ cm} = 0.25 \text{ m}$

Magnetic flux density =  $B = 0.25 \text{ T} = 0.25 \text{ NA}^{-1} \text{ m}^{-1}$

Induced emf =  $\epsilon = ?$

Using the relation,

$$\epsilon = vBL$$

$$\epsilon = 0.5 \text{ ms}^{-1} \times 0.25 \text{ NA}^{-1} \text{ m}^{-1} \times 0.25 \text{ m}$$

$$\epsilon = 3.13 \times 10^{-2} \text{ JC}^{-1} = 3.13 \times 10^{-2} \text{ V}$$

**15.3 FARADAY'S LAW AND INDUCED EMF**

The motional emf induced in a rod moving perpendicular to a magnetic field is  $\epsilon = -vBL$ . The motional emf as well as other induced emfs can be described in terms of magnetic flux. Consider the experiment shown in Fig. 15.8 again. Let the conducting rod  $L$  moves from position 1 to position 2 in a small interval of time  $\Delta t$ . The distance travelled by the rod in time  $\Delta t$  is  $x_2 - x_1 = \Delta x$



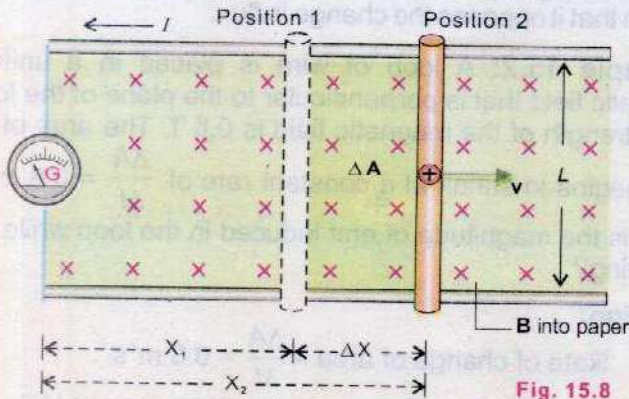


Fig. 15.8

Since the rod is moving with constant velocity  $v$ , therefore

$$v = \frac{\Delta x}{\Delta t} \quad \dots \dots \dots (15.5)$$

From Eq.15.3

$$\epsilon = -vBL = -\frac{\Delta x}{\Delta t} BL \quad \dots \dots \dots (15.6)$$

As the rod moves through the distance  $\Delta x$ , the increase in the area of loop is given by  $\Delta A = \Delta x.L$ . This increases the flux through the loop by  $\Delta \Phi = \Delta A.B = \Delta x.L.B$ . Putting  $\Delta x.L.B = \Delta \Phi$  in Eq.15.6, we get

$$\epsilon = -\frac{\Delta \Phi}{\Delta t} \quad \dots \dots \dots (15.7)$$

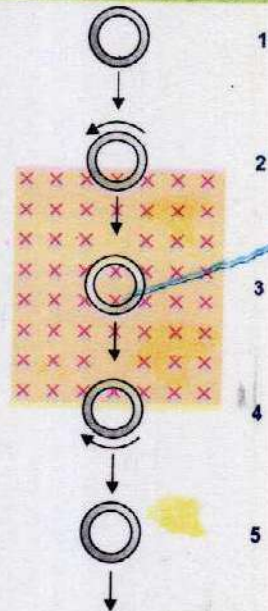
If there is a coil of  $N$  loops instead of a single loop, then the induced emf will become  $N$  times, i.e.,

$$\epsilon = -N \frac{\Delta \Phi}{\Delta t} \quad \dots \dots \dots (15.8)$$

Although the above expression is derived on the basis of motional emf, but it is true in general. This conclusion was first arrived at by Faraday, so this is known as Faraday's law of electromagnetic induction which states that

**"The average emf induced in a conducting coil of  $N$  loops is equal to the negative of the rate at which the magnetic flux through the coil is changing with time".**

Point to Ponder



A copper ring passes through a rectangle region where a constant magnetic field is directed into the page. What do you guess about the current in the ring at the positions 2, 3 and 4?



The minus sign indicates that the direction of the induced emf is such that it opposes the change in flux.

**Example 15.2:** A loop of wire is placed in a uniform magnetic field that is perpendicular to the plane of the loop. The strength of the magnetic field is 0.6 T. The area of the loop begins to shrink at a constant rate of  $\frac{\Delta A}{\Delta t} = 0.8 \text{ m}^2\text{s}^{-1}$ . What is the magnitude of emf induced in the loop while it is shrinking?

**Solution:**

$$\text{Rate of change of area} = \frac{\Delta A}{\Delta t} = 0.8 \text{ m}^2\text{s}^{-1}.$$

$$\text{Magnetic flux density} = B = 0.6 \text{ T} = 0.6 \text{ NA}^{-1}\text{m}^{-1}$$

$$\text{Number of turns} = N = 1$$

$$\text{Induced emf} = \varepsilon = ?$$

$$\text{Rate of change of flux} = \frac{\Delta\Phi}{\Delta t} = B \frac{\Delta A}{\Delta t} \cos 0^\circ = B \frac{\Delta A}{\Delta t}$$

Applying Faraday's Law, magnitude of induced emf

$$\begin{aligned}\varepsilon &= N \frac{\Delta\Phi}{\Delta t} = NB \frac{\Delta A}{\Delta t} \\ &= 1 \times 0.6 \text{ NA}^{-1}\text{m}^{-1} \times 0.8 \text{ m}^2\text{s}^{-1} \\ \varepsilon &= 0.48 \text{ JC}^{-1} = 0.48 \text{ V}\end{aligned}$$

## 15.4 LENZ'S LAW AND DIRECTION OF INDUCED EMF

In the previous section, a mathematical expression of the Faraday's law of electromagnetic induction was derived as

$$\varepsilon = -N \frac{\Delta\Phi}{\Delta t}$$

The minus sign in the expression is very important. It has to do with the direction of the induced emf. To determine the direction we use a method based on the discovery made by the Russian Physicist Heinrich Lenz in 1834. He found that the polarity of an induced emf always leads to an induced current that opposes, through the magnetic field of the induced current, the change inducing the emf. The rule is known as Lenz's law which states that

**"The direction of the induced current is always so as to oppose the change which causes the current".**



The Lenz's law refers to induced currents and not to induced emf, which means that we can apply it directly to closed conducting loops or coils. However, if the loop is not closed we can imagine as if it were closed, and then from the direction of induced current, we can find the direction of the induced emf.

Let us apply the Lenz's law to the coil in which current is induced by the movement of a bar magnet. We know that a current carrying coil produces a magnetic field similar to that of a bar magnet. One face of the coil acts as the north pole while the other one as the south pole. If the coil is to oppose the motion of the bar magnet, the face of the coil towards the magnet must become a north pole (Fig. 15.9). The two north poles will then repel each other. The right hand rule applied to

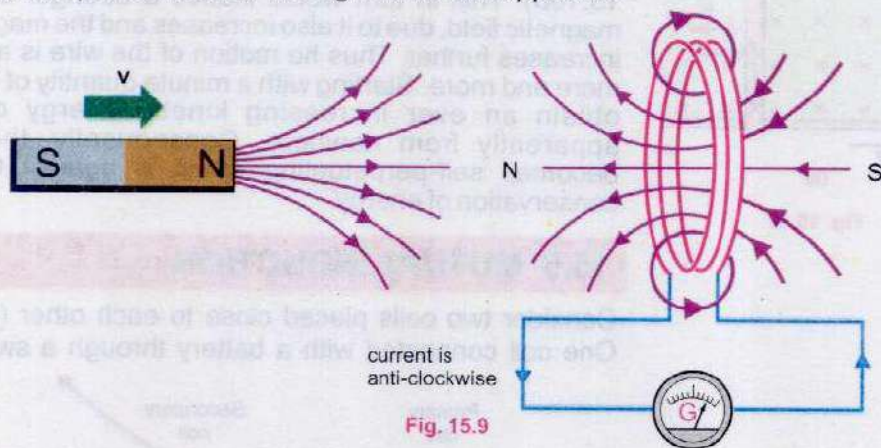


Fig. 15.9

the coil suggests that the induced current must be anti-clockwise as seen from the side of the bar magnet.

According to Lenz's law the "push" of the magnet is the "change" that produces the induced current, and the current acts to oppose the push. On the other hand if we pull the magnet away from the coil the induced current will oppose the "pull" by creating a south pole on the face of coil towards the bar magnet.

The Lenz's law is also a statement of law of conservation of energy that can be conveniently applied to the circuits involving induced currents. To understand this, consider once again the experiment in Fig. 15.8. When the rod moves towards right, emf is induced in it and an induced current flows through the loop in the anti-clockwise direction. Since the



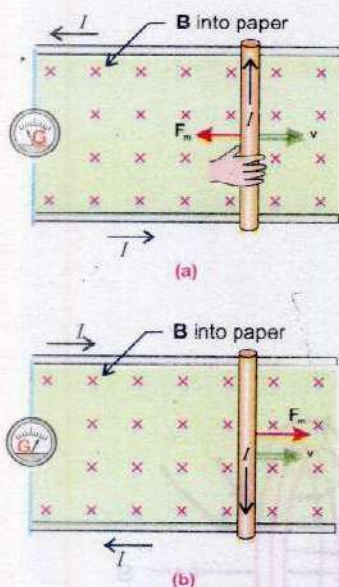


Fig. 15.10

current carrying rod is moving in the magnetic field, it experiences a magnetic force  $F_m$  having the magnitude  $F_m = ILB\sin 90^\circ$ . By right hand rule the direction of  $F_m$  is opposite to that of  $v$ , so it tends to stop the rod (Fig. 15.10 a). An external dragging force equal to  $F_m$  in magnitude but opposite in direction must be applied to keep the rod moving with constant velocity. This dragging force provides the energy for the induced current to flow. This energy is the source of induced current, thus electromagnetic induction is exactly according to law of conservation of energy.

The Lenz's law forbids the induced current directed clockwise in this case, because the force  $F_m$  would be, then, in the direction of  $v$  that would accelerate the rod towards right (Fig. 15.10b). This in turn would induce a stronger current, the magnetic field, due to it also increases and the magnetic force increases further. Thus the motion of the wire is accelerated more and more. Starting with a minute quantity of energy, we obtain an ever increasing kinetic energy of motion, apparently from nowhere. Consequently, the process becomes self-perpetuating which is against the law of conservation of energy.

## 15.5 MUTUAL INDUCTION

Consider two coils placed close to each other (Fig.15.11). One coil connected with a battery through a switch and a

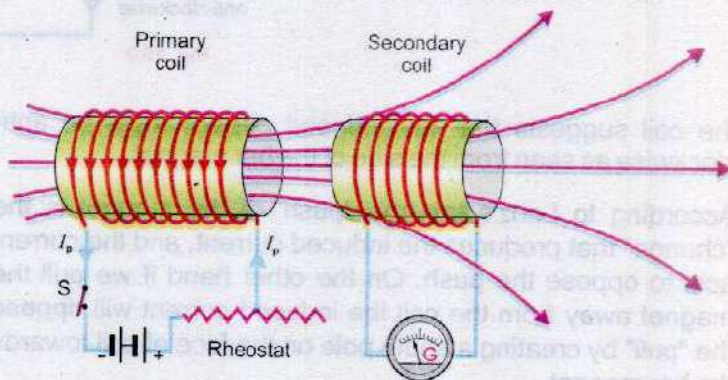


Fig. 15.11

rheostat is called the "primary" and the other one connected to the galvanometer is called the "secondary". If the current in the primary is changed by varying the resistance of the rheostat, the magnetic flux in the surrounding region



changes. Since the secondary coil is in the magnetic field of the primary, the changing flux also links with the secondary. This causes an induced emf in the secondary.

**The phenomenon in which a changing current in one coil induces an emf in another coil is called the mutual induction.**

According to Faraday's law, the emf induced in the secondary coil is proportional to the rate of change of flux

$$\frac{\Delta\Phi_s}{\Delta t} \text{ passing through it, i.e., } \epsilon_s = -N_s \frac{\Delta\Phi_s}{\Delta t}$$

where  $N_s$  is the number of turns in the secondary coil.

Let the flux passing through one loop of the secondary coil be  $\Phi_s$ . Net flux passing through the coil of  $N_s$  loops is  $N_s\Phi_s$ . As this flux is proportional to the magnetic field produced by the current  $I_p$  in the primary and the magnetic field itself is proportional to  $I_p$ , therefore

$$N_s\Phi_s \propto I_p$$

$$N_s\Phi_s = MI_p \quad \dots\dots\dots (15.9)$$

Where  $M = \frac{N_s\Phi_s}{I_p}$  is proportionality constant called the

mutual inductance of the two coils. It depends upon the number of turns of the coils, their area of cross-section, their closeness together and the nature of the core material upon which the two coils are wound.

By Faraday's law the emf induced in the secondary coil is given by the rate of change of flux through the secondary.

$$\epsilon_s = -N_s \frac{\Delta\Phi_s}{\Delta t} = - \frac{\Delta N_s\Phi_s}{\Delta t}$$

Putting  $N_s\Phi_s = MI_p$  from Eq.15.9

$$\epsilon_s = - \frac{\Delta(MI_p)}{\Delta t}$$

$$\epsilon_s = -M \frac{\Delta I_p}{\Delta t} \quad \dots\dots\dots (15.10)$$

The Eq.15.10 shows that the emf induced in the secondary is proportional to the time rate of change of current in the primary.



The negative sign in Eq.15.10 indicates the fact that the induced emf is in such a direction that it opposes the change of current in the primary coil. While finding out the value of  $M$  from Eq.15.10, negative sign is ignored. Thus  $M$  may be defined as the ratio of average emf induced in the secondary to the time rate of change of current in the primary.

$$M = \frac{\epsilon_s}{\Delta I_p / \Delta t}$$

The SI unit for the mutual inductance  $M$  is  $\text{Vs A}^{-1}$ , which is called as henry (H) after Joseph Henry.

One henry is the mutual inductance of the pair of coils in which the rate of change of current of one ampere per second in the primary causes an induced emf of one volt in the secondary.

**Example 15.3:** An emf of 5.6 V is induced in a coil while the current in a nearby coil is decreased from 100 A to 20 A in 0.02 s. What is the mutual inductance of the two coils? If the secondary has 200 turns, find the change in flux during this interval.

**Solution:**

emf induced in the secondary =  $\epsilon_s = 5.6 \text{ V}$   
 Change in current in primary =  $\Delta I_p = 100 \text{ A} - 20 \text{ A} = 80 \text{ A}$   
 Time interval for the change =  $\Delta t = 0.02 \text{ s}$   
 Mutual inductance =  $M = ?$   
 No. of turns in the secondary =  $N_s = 200$   
 Change in flux =  $\Delta \Phi = ?$

Using 
$$\epsilon_s = \frac{\Delta I_p}{\Delta t} M$$

$$5.6 \text{ V} = M \times \frac{80 \text{ A}}{0.02 \text{ s}}$$

$$M = \frac{5.6 \text{ V} \times 0.02 \text{ s}}{80 \text{ A}} = 1.4 \times 10^{-3} \text{ VsA}^{-1}$$

By Faraday's Law 
$$\epsilon_s = N_s \frac{\Delta \Phi}{\Delta t}$$

$$\Delta \Phi_s = \frac{\epsilon_s \Delta t}{N_s} = \frac{5.6 \text{ V} \times 0.02 \text{ s}}{200} = 5.6 \times 10^{-4} \text{ Wb}$$



## 15.6 SELF INDUCTION

According to Faraday's law, the change of flux through a coil by any means induces an emf in it. In all the examples we have discussed so far, induced emf was produced by a changing magnetic flux from some external source. But the change of flux through a coil may also be due to a change of current in the coil itself.

Consider the circuit shown in Fig. 15.12. A coil is connected in series with a battery and a rheostat. Magnetic flux is produced through the coil due to current in it. If the current is changed by varying the rheostat quickly, magnetic flux through the coil changes that causes an induced emf in the coil. Such an emf is called as self induced emf.

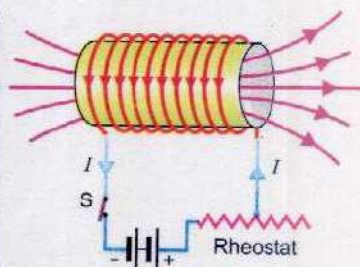


Fig. 15.12

**The phenomenon in which a changing current in a coil induces an emf in itself is called self induction.**

If the flux through one loop of the coil be  $\Phi$ , then the total flux through the coil of  $N$  turns would be  $N\Phi$ . As  $\Phi$  is proportional to the magnetic field which is in turn proportional to the current  $I$ , therefore

$$N\Phi \propto I$$

or 
$$N\Phi = LI \quad \dots\dots\dots (15.11)$$

where  $L = \frac{N\Phi}{I}$  is the constant of proportionality called the self inductance of the coil. It depends upon the number of turns of the coil, its area of cross-section and the core material. By winding the coil around a ferromagnetic (iron) core, the magnetic flux and hence the inductance can be increased significantly relative to that for an air core.

By Faraday's Law, emf induced in the coil is

$$\epsilon_L = -N \frac{\Delta\Phi}{\Delta t}$$

$$\epsilon_L = - \frac{\Delta(N\Phi)}{\Delta t}$$

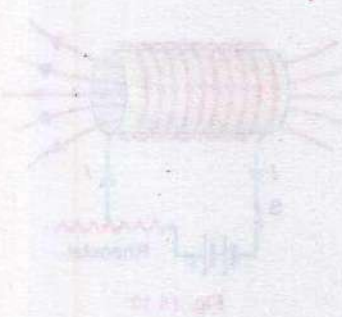
Putting  $N\Phi = LI$  from Eq.15.11

$$\epsilon_L = - \frac{\Delta(LI)}{\Delta t}$$

or 
$$\epsilon_L = -L \frac{\Delta I}{\Delta t} \quad \dots\dots\dots (15.12)$$



The Eq.15.12 shows that the self induced emf in a coil is proportional to the time rate of change of current in the coil. Self inductance  $L$  of a coil may be defined as the ratio of the emf to the rate of change of current in the coil. The unit of  $L$  is also henry (H).



The negative sign in Eq.15.12 indicates that the self induced emf must oppose the change that produced it. That is why the self induced emf is sometimes called as back emf. This is exactly in accord with the Lenz's law. If the current is increased, the induced emf will be opposite to that of battery and if the current is decreased the induced emf will aid, rather than opposing the battery. Because of their self inductance, coils of wire are known as inductors, and are widely used in electronics. In alternating current, inductors behave like resistors.

**Example 15.4:** The current in a coil of 1000 turns is changed from 5 A to zero in 0.2 s. If an average emf of 50 V is induced during this interval, what is the self inductance of the coil? What is the flux through each turn of the coil when a current of 6 A is flowing?

**Solution:**

$$\text{Change in current} = \Delta I = 5\text{A} - 0 = 5\text{A}$$

$$\text{Time interval} = \Delta t = 0.2\text{ s}$$

$$\text{emf induced} = \varepsilon = 50\text{ V}$$

$$\text{Self induction} = L = ?$$

$$\text{Steady current} = I = 6\text{ A}$$

$$\text{No. of turns of coil} = N = 1000$$

$$\text{Flux through each turn} = \Phi = ?$$

$$\text{Using } L = \frac{\varepsilon}{\Delta I / \Delta t} = \frac{50\text{ V}}{5\text{ A} / 0.2\text{ s}} = \frac{50\text{ V}}{5\text{ A} / 0.2\text{ s}}$$

$$L = 2\text{ VsA}^{-1} = 2\text{ H}$$

Now, using Eq.15.11

$$N\Phi = LI \quad \text{or} \quad \Phi = \frac{LI}{N}$$

$$\Phi = \frac{2\text{ H} \times 6\text{ A}}{1000} = 1.2 \times 10^{-2}\text{ Wb}$$



## 15.7 ENERGY STORED IN AN INDUCTOR

We have studied in chapter 12 that energy can be stored in the electric field between the plates of a capacitor. In a similar manner, energy can be stored in the magnetic field of an inductor.

Consider a coil connected to a battery and a switch in series (Fig. 15.13). When the switch is turned on voltage  $V$  is applied across the ends of the coil and current through it rises from zero to its maximum value  $I$ . Due to change of current, an emf is induced, which is opposite to that of battery. Work is done by the battery to move charges against the induced emf.

Work done by the battery in moving a small charge  $\Delta q$  is

$$W = \Delta q \varepsilon_L \quad \dots \dots \dots (15.13)$$

where  $\varepsilon_L$  is the magnitude of induced emf, given by

$$\varepsilon_L = L \frac{\Delta I}{\Delta t}$$

Putting the value of  $\varepsilon_L$  in Eq. 15.13 we get

$$W = \Delta q L \frac{\Delta I}{\Delta t} = \frac{\Delta q}{\Delta t} \cdot L \Delta I \quad \dots \dots \dots (15.14)$$

Total work done in establishing the current from 0 to  $I$  is found by inserting for  $\frac{\Delta q}{\Delta t}$ , the average current, and the value of  $\Delta I$ .

$$\text{Average current} = \frac{\Delta q}{\Delta t} = \frac{0 + I}{2} = \frac{1}{2} I$$

$$\text{Change in current} = \Delta I = I - 0 = I$$

$$\text{Total work } W = \left( \frac{1}{2} I \right) L I$$

$$W = \frac{1}{2} L I^2$$

This work is stored as potential energy in the inductor. Hence the energy stored in an inductor is

$$U_m = \frac{1}{2} L I^2 \quad \dots \dots \dots (15.15)$$

As in case of a capacitor, energy is stored in the electric field between the plates, likewise, in an inductor, energy is stored in the magnetic field. Therefore, Eq. 15.15 can be expressed in terms of the magnetic field  $\mathbf{B}$  of a solenoid which has  $n$  turns per unit length and area of cross section  $\mathbf{A}$ . The magnetic field strength inside it is  $B = \mu_0 n I$ . Since flux through the coil is

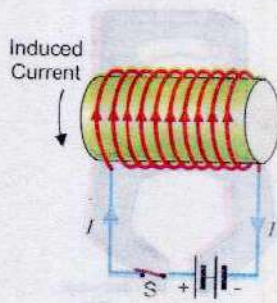
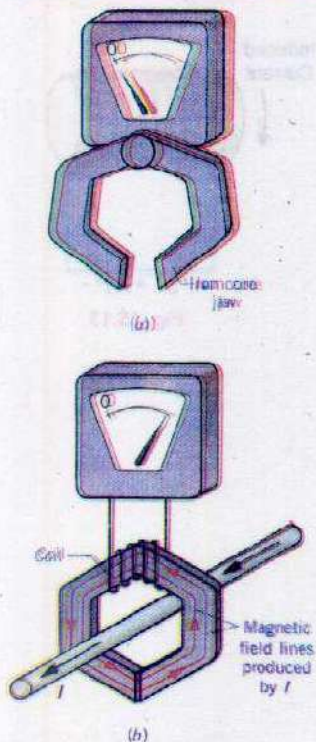


Fig. 15.13



**For Your Information**



An induction ammeter with its iron-core jaw (a) open and (b) closed around a wire carrying an alternating current  $I$ . Some of the magnetic field lines that encircle the wire are routed through the coil by the iron core and lead to an induced emf. The meter detects the emf and is calibrated to display the amount of current in the wire.

$$\Phi = BA$$

$$\text{or } \Phi = \mu_0 nIA \quad \dots\dots\dots (15.16)$$

Substituting the value of  $\Phi$  in Eq. 15.11

$$N\Phi = LI \quad \text{or} \quad L = \frac{N\Phi}{I}$$

we have

$$L = N \frac{\mu_0 nIA}{I} = N \mu_0 nA$$

If  $l$  is the length of solenoid, then putting  $N = nl$  in above Eq. we get the self inductance of the solenoid as

$$L = (nl) \mu_0 nA$$

$$L = \mu_0 n^2 A l \quad \dots\dots\dots (15.17)$$

Substituting for  $L$ , the Eq. 15.15 becomes,

$$U_m = \frac{1}{2} (\mu_0 n^2 A l) I^2 \quad \dots\dots\dots (15.18)$$

Since  $B$  for a solenoid is given by  $B = \mu_0 nI$  or  $I = \frac{B}{\mu_0 n}$

Substituting for  $I$ , Eq. 15.18 becomes

$$U_m = \frac{1}{2} (\mu_0 n^2 A l) \left( \frac{B}{\mu_0 n} \right)^2$$

$$U_m = \frac{1}{2} \frac{B^2}{\mu_0} (A l) \quad \dots\dots\dots (15.19)$$

Now energy density can be defined as the energy stored per unit volume inside the solenoid, so dividing Eq. 15.19 by the volume ( $A l$ ), we get energy density,

$$u_m = \frac{1}{2} \frac{B^2}{\mu_0} \quad \dots\dots\dots (15.20)$$

**Example 15.5:** A solenoid coil 10.0 cm long has 40 turns per cm. When the switch is closed, the current rises from zero to its maximum value of 5.0 A in 0.01 s. Find the energy stored in the magnetic field if the area of cross-section of the solenoid be 28 cm<sup>2</sup>.

**Solution:**

$$\text{Length of solenoid} = l = 10.0 \text{ cm} = 0.1 \text{ m}$$

$$\text{No. of turns} = n = 40 \text{ per cm} = 4000 \text{ per m}$$



$$\text{Area of cross section} = A = 28 \text{ cm}^2 = 2.8 \times 10^{-3} \text{ m}^2$$

$$\text{Steady current} = I = 5 \text{ A}$$

$$\text{Energy Stored} = U_m = ?$$

First, we calculate the inductance  $L$  using the Eq. (15.17)

$$L = \mu_0 n^2 Al$$

$$= (4\pi \times 10^{-7}) \text{ WbA}^{-1}\text{m}^{-1} \times (4000 \text{ m}^{-1})^2 \times 2.8 \times 10^{-3} \text{ m}^2 \times 0.1 \text{ m}$$

$$= 5.63 \times 10^{-3} \text{ WbA}^{-1} = 5.63 \times 10^{-3} \text{ H}$$

$$\text{Energy stored} = U_m = \frac{1}{2} LI^2 = \frac{1}{2} (5.63 \times 10^{-3} \text{ NmA}^{-2}) \times (5 \text{ A})^2$$

$$= 7.04 \times 10^{-2} \text{ Nm} = 7.04 \times 10^{-2} \text{ J}$$

## 15.8 ALTERNATING CURRENT GENERATOR

We have learnt that when a current carrying coil is placed in a magnetic field, a torque acts on it that rotates the coil. What happens if a coil of wire is rotated in a magnetic field? Can a current be produced in the coil? Yes, it does. Such a device is called a current generator.

**A current generator is a device that converts mechanical energy into electrical energy.**

The principle of an electric generator is based on Faraday's law of electromagnetic induction. When a coil is rotated in a magnetic field by some mechanical means, magnetic flux through the coil changes, and consequently an emf is induced in the coil.

If the generator is connected to an external circuit, an electric current is the output of the generator.

Let a rectangular loop of wire of area  $A$  be placed in a uniform magnetic field  $\mathbf{B}$  (Fig.15.14). The loop is rotated about z-axis through its centre at constant angular velocity  $\omega$ . One end of the loop is attached to a metal ring  $R$  and the other end to the ring  $R'$ . These rings, called the slip rings are concentric with the axis of the loop and rotate with it. Rings  $R$   $R'$  slide against stationary carbon brushes to which external circuit is connected.

To calculate the induced emf in the loop, consider its position (Fig.15.15) while it is rotating anticlockwise. The figure shows the top view of the coil. The vertical side  $ab$  of the loop is moving with velocity  $\mathbf{v}$  in the magnetic field  $\mathbf{B}$ . If the angle between  $\mathbf{v}$  and  $\mathbf{B}$  be  $\theta$ , the motional emf induced in the side  $ab$  has the magnitude,

$$\epsilon_{ab} = vBL \sin\theta$$

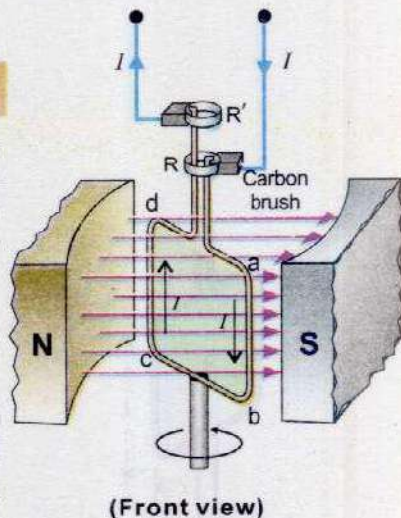


Fig.15.14

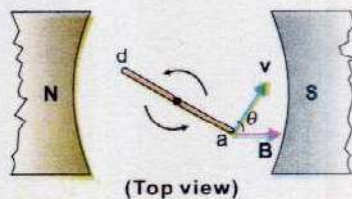


Fig. 15.15



The direction of induced current in the wire  $ab$  is the same as that of force  $\mathbf{F}$  experienced by the charges in the wire, i.e., from top to the bottom. The same amount of emf is induced in the side  $cd$  but the direction of current is from bottom to the top.

Therefore  $\epsilon_{cd} = vBL \sin \theta$

The net contribution to emf by sides  $bc$  and  $da$  is zero because the force acting on the charges inside  $bc$  and  $da$  is not along the wire.

Thus  $\epsilon_{bc} = \epsilon_{da} = 0$

Since both the emfs in the sides  $ab$  and  $cd$  drive current in the same direction around the loop, the total emf in the loop is

$$\epsilon = \epsilon_{ab} + \epsilon_{cd}$$

$$\epsilon = vBL \sin \theta + vBL \sin \theta$$

$$\epsilon = 2vBL \sin \theta$$

If the loop is replaced by a coil of  $N$  turns, the total emf in the coil will be,

$$\epsilon = 2NvBL \sin \theta \quad \dots \dots \dots (15.21)$$

The linear speed  $v$  of the vertical wire is related to the angular speed  $\omega$  by the relation

$$v = \omega r$$

where  $r$  is the distance of the vertical wires from the centre of the coil. Substituting  $\omega r$  for  $v$  in Eq. (15.21)

We get

$$\epsilon = 2N(\omega r)BL \sin \theta$$

$$\epsilon = N\omega(2rL)B \sin \theta$$

$$\epsilon = N\omega AB \sin \theta \quad \dots \dots \dots (15.22)$$

where  $A = 2rL =$  area of the coil

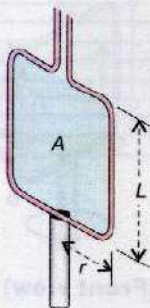
As the angular displacement  $\theta = \omega t$ , so the Eq.15.22 becomes

$$\epsilon = N\omega AB \sin(\omega t) \quad \dots \dots \dots (15.23)$$

Eq.15.23 shows that the induced emf varies sinusoidally with time.

It has the maximum value  $\epsilon_0$  when  $\sin(\omega t)$  is equal to 1. Thus

$$\epsilon_0 = N\omega AB \quad \dots \dots \dots (15.24)$$





The Eq. 15.23 can be written as,

$$\epsilon = \epsilon_0 \sin(\omega t) \quad \dots\dots\dots (15.25)$$

If  $R$  is the resistance of the coil, then by Ohm's law, induced current in the coil will be

$$I = \frac{\epsilon}{R} = \frac{\epsilon_0 \sin(\omega t)}{R} = \frac{\epsilon_0}{R} \sin(\omega t)$$

or  $I = I_0 \sin(\omega t) \quad \dots\dots\dots (15.26)$

where  $I_0$  is maximum current.

Angular speed  $\omega$  of the coil is related to its frequency of rotation  $f$  as,  $\omega = 2\pi f$

The Eqs. 15.25 and 15.26 can be written as

$$\epsilon = \epsilon_0 \sin(2\pi f t) \quad \dots\dots\dots (15.27)$$

$$I = I_0 \sin(2\pi f t) \quad \dots\dots\dots (15.28)$$

Eq. 15.28 indicates the variation of current as a function of  $\theta = 2\pi f t$ . Fig. 15.16 shows the graph for the current corresponding to different positions of one loop of the coil.

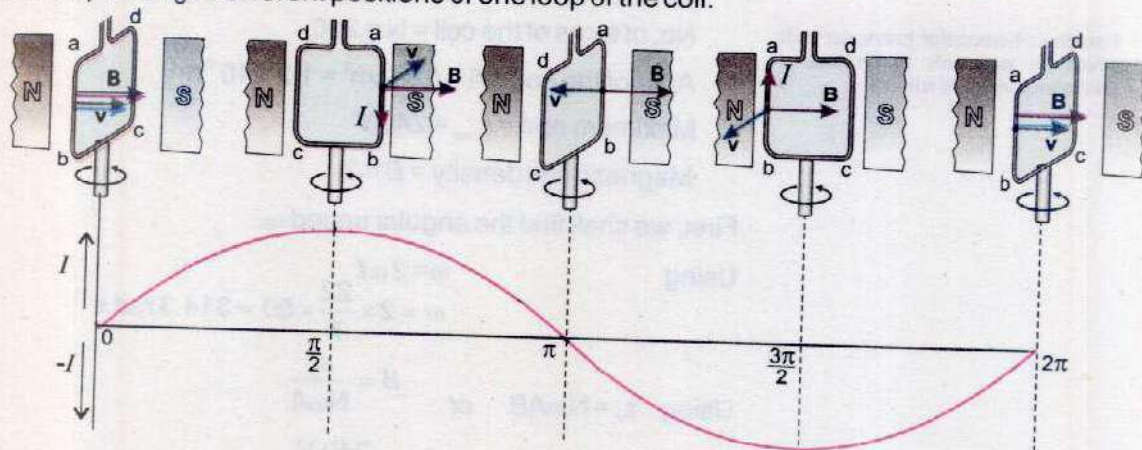


Fig. 15.16

When the angle between  $\mathbf{v}$  &  $\mathbf{B}$  is  $\theta = 0^\circ$ , the plane of the loop is perpendicular to  $\mathbf{B}$ , current is zero. As  $\theta$  increases, current also increases and at  $\theta = 90^\circ = \pi/2$  rad, the loop is parallel to  $\mathbf{B}$ , current is maximum, directed along  $abcd$ . On further increase in  $\theta$  current decreases, and at  $\theta = 180^\circ = \pi$  rad the current becomes zero as the loop is again perpendicular to  $\mathbf{B}$ . For  $180^\circ < \theta < 270^\circ$  current increases but reverses its direction as is clear from the figure. Current is now directed along  $dcba$ . At  $\theta = 270^\circ = 3\pi/2$  rad, current is maximum in



### For Your Information



Faraday's homopolar generator with which he was able to produce a continuous induced current.

the reverse direction as the loop is parallel to  $\mathbf{B}$ . At  $\theta = 360^\circ = 2\pi$  rad, one rotation is completed, the loop is perpendicular to  $\mathbf{B}$  and the current decreases to zero. After one rotation the cycle repeats itself. The current alternates in direction once in one cycle. Therefore, such a current is called the alternating current. It reverses its direction  $f$  times per second.

In actual practice a number of coils are wound around an iron cylinder which is rotated in the magnetic field. This assembly is called an armature. The magnetic field is usually provided by an electromagnet. Armature is rotated by a fuel engine or a turbine run by a waterfall. In some commercial generators, field magnet is rotated around a stationary armature.

**Example 15.6:** An alternating current generator operating at 50 Hz has a coil of 200 turns. The coil has an area of  $120 \text{ cm}^2$ . What should be the magnetic field in which the coil rotates in order to produce an emf of maximum value of 240 volts?

#### Solution:

$$\text{Frequency of rotation} = f = 50 \text{ Hz}$$

$$\text{No. of turns of the coil} = N = 200$$

$$\text{Area of the coil} = A = 120 \text{ cm}^2 = 1.2 \times 10^{-2} \text{ m}^2$$

$$\text{Maximum emf} = \epsilon_{\text{max}} = 240 \text{ V}$$

$$\text{Magnetic flux density} = B = ?$$

First, we shall find the angular speed  $\omega$ .

$$\begin{aligned} \text{Using } \omega &= 2\pi f \\ \omega &= 2 \times \frac{22}{7} \times 50 = 314.3 \text{ rad s}^{-1} \end{aligned}$$

$$\text{Using } \epsilon_o = N\omega AB \quad \text{or} \quad B = \frac{\epsilon_o}{N\omega A}$$

$$B = \frac{240 \text{ V}}{200 \times 314.3 \text{ rad s}^{-1} \times 1.2 \times 10^{-2} \text{ m}^2}$$

$$B = 0.32 \text{ Vs rad}^{-1} \text{ m}^{-2} = 0.32 \text{ T}$$

## 15.9 D.C. GENERATOR

Alternating current generators are not suitable for many applications, for example, to run a D.C. Motor. In 1834, William Sturgeon invented a simple device called a commutator that prevents the direction of current from



changing. Therefore a D.C. generator is similar to the A.C. generator in construction with the difference that "slip rings" are replaced by "split rings". The "split rings" are two halves of a ring that act as a commutator. Fig. 15.17 shows the "split rings" A and A' attached to the two ends of the coil that rotates in the magnetic field. When the current in the coil is zero and is about to change direction, the split rings also change the contacts with the carbon brushes BB'. In this way the output from BB' remains in the same direction, although the current is not constant in magnitude. The curve of the current is shown in Fig. 15.18. It is similar to a sine curve with the lower half inverted. The fluctuations of the output can be significantly reduced by using many coils rather than a single one. Multiple coils are wound around a cylindrical core to form the armature. Each coil is connected to a separate commutator and the output of every coil is tapped only as it reaches its peak emf. Thus the emf in the outer circuit is almost constant.

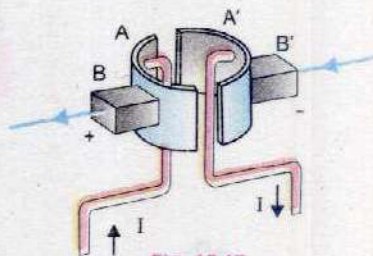


Fig. 15.17

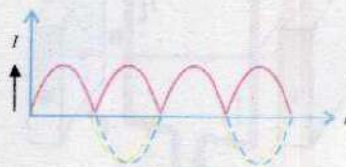
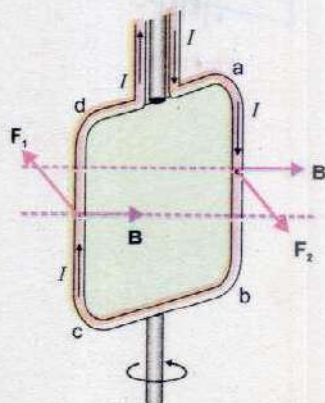


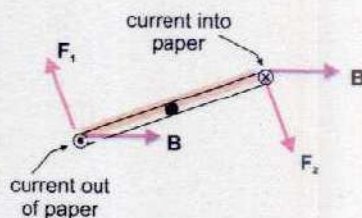
Fig. 15.18

### 15.10 BACK MOTOR EFFECT IN GENERATORS

A generator is the source of electricity production. Practically, the generators are not so simple as described above. A large turbine is turned by high pressure steam or waterfall. The shaft of the turbine is attached to the coil which rotates in a magnetic field. It converts the mechanical energy of the driven turbine to electrical energy. The generator supplies current to the external circuit. The devices in the circuit that consume electrical energy are known as the "load". The greater the load the larger the current is supplied by the generator. When the circuit is open, the generator does not supply electrical energy, and a very little force is needed to rotate the coil. As soon as the circuit is closed, a current is drawn through the coil. The magnetic field exerts force on the current carrying coil. Fig. 15.19 shows the forces acting on the coil. Force  $F_1$  is acting on the left side of the coil whereas an equal but opposite force  $F_2$  acts on the right side of the coil. These forces are such that they produce a counter torque that opposes the rotational motion of the coil. This effect is sometimes referred to as back motor effect in the generators. The larger the current drawn, the greater is the counter torque produced. That means more mechanical energy is required to keep the coil rotating with constant angular speed. This is in agreement with the law of conservation of energy. The



(a) Front view



(b) Top view

Fig. 15.19



energy consumed by the "load" must come from the "energy source" used to drive the turbine.

## 15.11 D.C. MOTOR

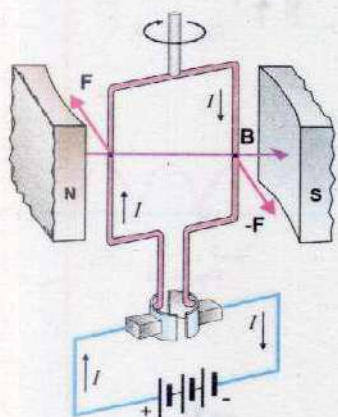


Fig. 15.20

A motor is a device which converts electrical energy into mechanical energy. We already know that a wire carrying current placed in a magnetic field experiences a force. This is the basic principle of an electric motor. In construction a D.C. motor is similar to a D.C. generator, having a magnetic field, a commutator and an armature. In the generator, the armature is rotated in the magnetic field and current is the output. In the D.C. motor, current passes through the armature that rotates in the magnetic field. In the D.C. motor, the brushes are connected to a D.C. supply or battery (Fig.15.20). When current flows through the armature coil, the force on the conductors produces a torque, that rotates the armature. The amount of this torque depends upon the current, the strength of the magnetic field, the area of the coil and the number of turns of the coil.

If the current in the coil were all the time in the same direction, the torque on it would be reversed after each half revolution. But at this moment, commutator reverses the direction of current that keeps the torque always in the same sense. A little problem arises due to the use of commutator, that is, the torque vanishes each time the current changes its direction. This creates jerks in the smooth running of the armature. However the problem is overcome by using more than one coil wrapped around a soft-iron core. This results in producing a more steady torque.

The magnetic field in the motor, is provided by a permanent magnet or an electromagnet. The windings of the electromagnet are usually called the field coils. The field coils may be in series or in parallel to the armature coils.

## 15.12 BACK EMF EFFECT IN MOTORS

A motor is just like a generator running in reverse. When the coil of the motor rotates across the magnetic field by the applied potential difference  $V$ , an emf  $\epsilon$  is induced in it. The induced emf is in such a direction that opposes the emf running the motor. Due to this reason the induced emf is called back emf of the motor. The magnitude of the back emf increases with the speed of motor.

Since  $V$  and  $\epsilon$  are opposite in polarity, the net emf in the circuit is  $V - \epsilon$ . If  $R$  is the resistance of the coil and  $I$  the current drawn



by the motor, then by Ohm's law

$$I = \frac{V - \epsilon}{R} \quad \text{or} \quad V = \epsilon + IR \quad \dots\dots\dots (15.29)$$

When the motor is just started, back emf is almost zero and hence a large current passes through the coil. As the motor speeds up, the back emf increases and the current becomes smaller and smaller. However, the current is sufficient to provide torque on the coil to drive the load and to overcome losses due to friction. If the motor is overloaded, it slows down. Consequently, the back emf decreases and allows the motor to draw more current. If the motor is overloaded beyond its limits, the current could be so high that it may burn out the motor.

**Example 15.7:** A permanent magnet D.C motor is run by a battery of 24 volts. The coil of the motor has a resistance of 2 ohms. It develops a back emf of 22.5 volts when driving the load at normal speed. What is the current when motor just starts up? Also find the current when motor is running at normal speed.

**Solution:**

$$\text{Operation Voltage} = V = 24 \text{ V}$$

$$\text{Resistance of the coil} = R = 2 \Omega$$

$$\text{Back emf} = \epsilon = 22.5 \text{ V}$$

$$\text{Current} = I = ?$$

i) when motor just starts up, the back emf  $\epsilon = 0$

Using

$$V = \epsilon + IR$$

$$24 \text{ V} = 0 + I \times 2 \Omega$$

$$I = \frac{24 \text{ V}}{2 \Omega} = 12 \text{ V} \Omega^{-1} = 12 \text{ A}$$

when motor runs at normal speed,  $\epsilon = 22.5 \text{ V}$

then using

$$V = \epsilon + IR$$

$$24 \text{ V} = 22.5 \text{ V} + I \times 2 \Omega$$

$$I = \frac{24 \text{ V} - 22.5 \text{ V}}{2 \Omega} = 0.75 \text{ V} \Omega^{-1} = 0.75 \text{ A}$$

## 15.13 TRANSFORMER

A transformer is an electrical device used to change a given alternating emf into a larger or smaller alternating emf. It



works on the principle of mutual induction between two coils.

In principle, the transformer consists of two coils of copper, electrically insulated from each other, wound on the same iron core. The coil to which A.C power is supplied is called primary and that from which power is delivered to the circuit is called the secondary.

It should be noted that there is no electrical connection between the two coils but they are magnetically linked. Suppose that an alternating emf is applied to the primary. If at some instant  $t$  the flux in the primary is changing at the rate of  $\Delta\Phi/\Delta t$  then there will be back emf induced in the primary which will oppose the applied voltage. The instantaneous value of the self induced emf is given by

$$\text{Self induced emf} = -N_p \left[ \frac{\Delta\Phi}{\Delta t} \right]$$

If the resistance of the coil is negligible then the back emf is equal and opposite to applied voltage  $V_p$ .

$$V_p = -\text{back emf} = N_p \left[ \frac{\Delta\Phi}{\Delta t} \right] \dots\dots\dots (15.30)$$

where  $N_p$  is the number of turns in the primary.

Assuming the flux through the primary also passes through the secondary, i.e., the two coils are tightly coupled, the rate of change of flux in the secondary will also be  $\Delta\Phi/\Delta t$  and the magnitude of the induced emf across the secondary is given by

$$V_s = N_s \left[ \frac{\Delta\Phi}{\Delta t} \right] \dots\dots\dots (15.31)$$

where  $N_s$  is the number of turns in the secondary

Dividing Eq.15.31 by Eq.15.30, we get

$$\frac{V_s}{V_p} = \frac{N_s}{N_p} \dots\dots\dots (15.32)$$

If  $N_s > N_p$  then according to Eq. 15.32,  $V_s > V_p$ , such a transformer in which voltage across secondary is greater than the primary voltage is called a step up transformer (Fig. 15.20 a). Similarly if  $N_s < N_p$ , i.e., the number of turns in the secondary is less than the number in primary, then  $V_s < V_p$ , such transformer in which voltage across secondary is less than the primary voltage is called a step down transformer (Fig. 15.20 b).

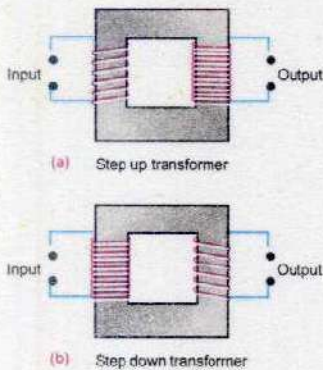


Fig. 15.20



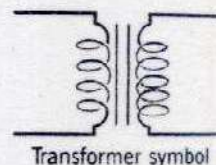
It is important to note that the electrical power in a transformer is transformed from its primary to the secondary coil by means of changing flux. For an ideal case the power input to the primary is nearly equal to the power output from the secondary i.e.,

Power input = Power output

i.e.,  $V_p I_p = V_s I_s$

or  $\frac{V_s}{V_p} = \frac{I_p}{I_s}$  ..... (15.33)

$I_p$  is the current in the primary and  $I_s$  in the secondary. The currents are thus inversely proportional to the respective voltages. Therefore, in a step up transformer when the voltage across the secondary is raised, the value of current is reduced. This is the principle behind its use in the electric supply network where transformer increases the voltage and reduces the current so that it can be transmitted over long distances without much power loss. When current  $I$  passes through a resistance  $R$ , the power loss due to heating effect is  $I^2R$ . Suppose  $R$  is the resistance of transmission line. In order to minimize the loss during transmission, it is not possible to reduce  $R$  because it requires the use of thick copper wire which becomes highly uneconomical. The purpose is well served by reducing  $I$ . At the generating power station the voltage is stepped up to several thousand of volts and power is transmitted at low current to long distances without much loss. Step down transformers then decrease the voltage to a safe value at the end of line where the consumer of electric power is located. Inside a house a transformer may be used to step down the voltage from 250 volts to 9 volts for ringing bell or operating a transistor radio. Transformers with several secondaries are used in television and radio receivers where several different voltages are required.



Only in an ideal transformer the output power is nearly equal to the input power. But in an actual transformer, this is not the case. The output is always less than input due to power losses. There are two main causes of power loss, namely eddy currents and magnetic hysteresis.

In order to enhance the magnetic flux, the primary and secondary coils of the transformer are wound on soft iron core. The flux generated by the coils also passes through the core. As magnetic flux changes through a solid conductor, induced currents are set up in closed paths in the body of the



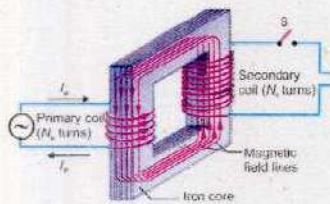


Fig. 15.21

conductor. These induced currents are set up in a direction perpendicular to the flux and are known as eddy currents. It results in power dissipation and heating of the core material. In order to minimize the power loss due to flow of these currents, the core is laminated with insulation in between the layers of laminations which stops the flow of eddy currents (Fig. 15.21). Hysteresis loss is the energy expended to magnetize and demagnetize the core material in each cycle of the A.C.

Due to these power losses, a transformer is far from being an ideal. Its output power is always less than its input power. The efficiency of a transformer is defined as

$$E = \frac{\text{output power}}{\text{input power}} \times 100$$

In order to improve the efficiency, care should be exercised, to minimize all the power losses. For example core should be assembled from the laminated sheets of a material whose hysteresis loop area is very small. The insulation between lamination sheets should be perfect so as to stop the flow of eddy currents. The resistance of the primary and secondary coils should be kept to a minimum. As power transfer from primary to secondary takes place through flux linkages, so the primary and secondary coils should be wound in such a way that flux coupling between them is maximum.

**Example 15.8:** The turns ratios of a step up transformer is 50. A current of 20 A is passed through its primary coil at 220 volts. Obtain the value of the voltage and current in the secondary coil assuming the transformer to be ideal one.

**Solution:**

$$\frac{N_s}{N_p} = 50 \quad , \quad I_p = 20 \text{ A}$$

$$V_p = 220 \text{ V} \quad V_s = ? \quad I_s = ?$$

Using the equation  $\frac{V_s}{V_p} = \frac{I_p}{I_s}$  we get  $\frac{V_s}{220} = 50$

Voltage in the secondary coil =  $V_s = 220 \times 50 = 1100$  volts

$$I_s = \frac{V_p}{V_s} \times I_p = \frac{1}{50} \times 20 = 0.4 \text{ A}$$



## SUMMARY

- An emf is set up in a conductor when it moves across a magnetic field. It is called an induced emf.
- The emf induced by the motion of a conductor across a magnetic field is called motional emf.
- Magnitude of motional emf in a rod of length  $L$  moving with velocity  $v$  across a magnetic field of strength  $B$  making  $\theta$  with it is  $\epsilon = vBL \sin \theta$
- Faraday's law states that the emf induced in a conducting coil of  $N$  loops is equal to the negative of the rate at which the magnetic flux through the coil is changing with time.
- The Lenz's law states that the direction of the induced current is always so as to oppose the change which causes the current.
- The phenomenon in which a changing current in one coil induces an emf in another coil is called the mutual induction.
- One henry is the mutual inductance of that pair of coils in which a change of current of one ampere per second in the primary causes an induced emf of one volt in the secondary.
- The phenomenon in which a changing current in a coil induces an emf in itself is called self induction.
- A current generator is a device that converts mechanical energy into electrical energy.
- The emf produced in a generator is  $\epsilon = N\omega AB \sin(\omega t)$  or  $\epsilon = \epsilon_0 \sin(2\pi ft)$ .
- A motor is a device, which converts electrical energy into mechanical energy.
- The induced emf in a motor opposes the emf running the motor. This induced emf is called the back emf of the motor.

## QUESTIONS

- 15.1 Does the induced emf in a circuit depend on the resistance of the circuit? Does the induced current depend on the resistance of the circuit?
- 15.2 A square loop of wire is moving through a uniform magnetic field. The normal to the loop is oriented parallel to the magnetic field. Is a emf induced in the loop? Give a reason for your answer.
- 15.3 A light metallic ring is released from above into a vertical bar magnet (Fig. Q. 15.3). Viewed from above, does the current flow clockwise or anticlockwise in the ring?

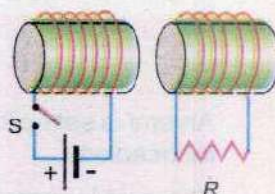


Fig. Q.15.3



- 15.4 What is the direction of the current through resistor  $R$  in Fig.Q.15.4?. When switch  $S$  is  
 (a) closed  
 (b) opened.

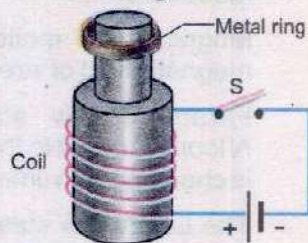
Fig. Q. 15.4



- 15.5 Does the induced emf always act to decrease the magnetic flux through a circuit?

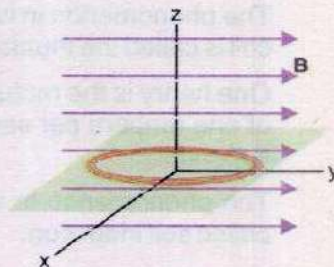
- 15.6 When the switch in the circuit is closed a current is established in the coil and the metal ring jumps upward (Fig.Q.15.6). Why? Describe what would happen to the ring if the battery polarity were reversed?

Fig. Q. 15.6



- 15.7 The Fig.Q.15.7 shows a coil of wire in the  $xy$  plane with a magnetic field directed along the  $y$  - axis. Around which of the three coordinate axes should the coil be rotated in order to generate an emf and a current in the coil?

Fig. Q. 15.7



- 15.8 How would you position a flat loop of wire in a changing magnetic field so that there is no emf induced in the loop?
- 15.9 In a certain region the earth's magnetic field point vertically down. When a plane flies due north, which wingtip is positively charged?
- 15.10 Show that  $\epsilon$  and  $\frac{\Delta\Phi}{\Delta t}$  have the same units.
- 15.11 When an electric motor, such as an electric drill, is being used, does it also act as a generator? If so what is the consequence of this?
- 15.12 Can a D.C motor be turned into a D.C generator? What changes are required to be done?
- 15.13 Is it possible to change both the area of the loop and the magnetic field passing through the loop and still not have an induced emf in the loop?
- 15.14 Can an electric motor be used to drive an electric generator with the output from the generator being used to operate the motor?
- 15.15 A suspended magnet is oscillating freely in a horizontal plane. The oscillations are strongly damped when a metal plate is placed under the magnet. Explain why this occurs?



- 15.16 Four unmarked wires emerge from a transformer. What steps would you take to determine the turns ratio?
- 15.17 a) Can a step-up transformer increase the power level?  
b) In a transformer, there is no transfer of charge from the primary to the secondary. How is, then the power transferred?
- 15.18 When the primary of a transformer is connected to a.c mains the current in it  
a) is very small if the secondary circuit is open, but  
b) increases when the secondary circuit is closed. Explain these facts.

### PROBLEMS

- 15.1 An emf of 0.45 V is induced between the ends of a metal bar moving through a magnetic field of 0.22 T. What field strength would be needed to produce an emf of 1.5 V between the ends of the bar, assuming that all other factors remain the same?  
(Ans: 0.73 T)
- 15.2 The flux density B in a region between the pole faces of a horse-shoe magnet is  $0.5 \text{ Wbm}^{-2}$  directed vertically downward. Find the emf induced in a straight wire 5.0 cm long, perpendicular to B when it is moved in a direction at an angle of  $60^\circ$  with the horizontal with a speed of  $100 \text{ cms}^{-1}$ .  
(Ans:  $1.25 \times 10^{-2} \text{ V}$ )
- 15.3 A coil of wire has 10 loops. Each loop has an area of  $1.5 \times 10^{-3} \text{ m}^2$ . A magnetic field is perpendicular to the surface of each loop at all times. If the magnetic field is changed from 0.05 T to 0.06 T in 0.1 s, find the average emf induced in the coil during this time.  
(Ans:  $+1.5 \times 10^{-3} \text{ V}$ )
- 15.4 A circular coil has 15 turns of radius 2 cm each. The plane of the coil lies at  $40^\circ$  to a uniform magnetic field of 0.2 T. If the field is increased by 0.5 T in 0.2 s, find the magnitude of the induced emf.  
(Ans:  $1.8 \times 10^{-2} \text{ V}$ )
- 15.5 Two coils are placed side by side. An emf of 0.8 V is observed in one coil when the current is changing at the rate of  $200 \text{ As}^{-1}$  in the other coil. What is the mutual inductance of the coils?  
(Ans: 4 mH)
- 15.6 A pair of adjacent coils has a mutual inductance of 0.75 H. If the current in the primary changes from 0 to 10 A in 0.025 s, what is the average induced emf in the secondary? What is the change in flux in it if the secondary has 500 turns?  
(Ans: 300 V,  $1.5 \times 10^2 \text{ Wb}$ )
- 15.7 A solenoid has 250 turns and its self inductance is 2.4 mH. What is the flux through each turn when the current is 2 A? What is the induced emf when the current changes at  $20 \text{ As}^{-1}$ ?  
(Ans:  $1.92 \times 10^{-5} \text{ Wb}$ , 48 mV)
- 15.8 A solenoid of length 8.0 cm and cross sectional area  $0.5 \text{ cm}^2$  has 520 turns. Find the self inductance of the solenoid when the core is air. If the current in the solenoid increases through 1.5 A in 0.2 s, find the magnitude of induced emf in it.  
( $\mu_0 = 4\pi \times 10^{-7} \text{ WbA}^{-1}\text{m}^{-1}$ )  
(Ans:  $1.6 \times 10^{-3} \text{ V}$ ,  $2.12 \times 10^{-4} \text{ H}$ )



- 15.9 When current through a coil changes from 100 mA to 200 mA in 0.005 s, an induced emf of 40 mV is produced in the coil. (a) What is the self inductance of the coil?  
(b) Find the increase in the energy stored in the coil. (Ans: 2 mH, 0.03 mJ)
- 15.10 Like any field, the earth's magnetic field stores energy. Find the magnetic energy stored in a space where strength of earth's field is  $7 \times 10^{-5}$  T, if the space occupies an area of  $10 \times 10^8$  m<sup>2</sup> and has a height of 750 m. (Ans:  $1.46 \times 10^9$  J)
- 15.11 A square coil of side 16 cm has 200 turns and rotates in a uniform magnetic field of magnitude 0.05 T. If the peak emf is 12 V, what is the angular velocity of the coil (Ans: 47 rad s<sup>-1</sup>)
- 15.12 A generator has a rectangular coil consisting of 360 turns. The coil rotates at 420 rev per min in 0.14 T magnetic field. The peak value of emf produced by the generator is 50 V. if the coil is 5.0 cm wide, find the length of the side of the coil. (Ans: 45 cm)
- 15.13 It is desired to make an a.c generator that can produce an emf of maximum value 5kV with 50 Hz frequency. A coil of area 1 m<sup>2</sup> having 200 turns is used as armature. What should be the magnitude of the magnetic field in which the coil rotates? (Ans: 0.08 T)
- 15.14 The back emf in a motor is 120 V when the motor is turning at 1680 rev per min. What is the back emf when the motor turns 3360 rev per min? (Ans: 240 V)
- 15.15 A D.C motor operates at 240 V and has a resistance of  $0.5 \Omega$ . When the motor is running at normal speed, the armature current is 15 A. Find the back emf in the armature. (Ans: 232.5 V)
- 15.16 A copper ring has a radius of 4.0 cm and resistance of  $1.0 \text{ m}\Omega$ . A magnetic field is applied over the ring, perpendicular to its plane. If the magnetic field increases from 0.2 T to 0.4 T in a time interval of  $5 \times 10^{-3}$  s, what is the current in the ring during this interval? (Ans: 201 A)
- 15.17 A coil of 10 turns and  $35 \text{ cm}^2$  area is in a perpendicular magnetic field of 0.5 T. The coil is pulled out of the field in 1.0 s. Find the induced emf in the coil as it is pulled out of the field. (Ans:  $1.75 \times 10^{-2}$  V)
- 15.18 An ideal step down transformer is connected to main supply of 240 V. It is desired to operate a 12 V, 30 W lamp. Find the current in the primary and the transformation ratio? (Ans: 0.125 A, 1/20)



# Chapter 16

## ALTERNATING CURRENT

### Learning Objectives

At the end of this chapter the students will be able to:

1. Understand and describe time period, frequency, the peak and root mean square values of an alternating current and voltage.
2. Know and use the relationship for the sinusoidal wave.
3. Understand the flow of A.C. through resistors, capacitors and inductors.
4. Understand how phase lags and leads in the circuit.
5. Apply the knowledge to calculate the reactances of capacitors and inductors.
6. Describe impedance as vector summation of resistances.
7. Know and use the formulae of A.C. power to solve the problems.
8. Understand the function of resonant circuits.
9. Appreciate the principle of metal detectors used for security checks.
10. Describe the three phase A.C. supply.
11. Become familiar with electromagnetic spectrum (ranging from radio waves to  $\gamma$  rays).
12. Know the production, transmission and reception of electromagnetic waves.

**W**e have read in the last chapter that an A.C. generator produces alternating voltage/current. Now a days most of the electrical energy is produced by A.C. generators using water power or huge steam turbines. The main reason for the world wide use of A.C. is that it can be transmitted to long distances easily and at a very low cost.

### 16.1 ALTERNATING CURRENT

Alternating current (A.C.) is that which is produced by a voltage source whose polarity keeps on reversing with time (Fig. 16.1 a,b). In Fig. 16.1 (a), the terminal A of the source is positive with respect to terminal B and it remains so during a time interval  $0$  to  $T/2$ . At  $t = T/2$ , the terminals change their polarity. Now A becomes negative with respect to B (Fig. 16.1 b). This state continues during the time interval  $T/2$  to  $T$ , after which terminal A again becomes positive with respect to B and the next cycle starts. As a result of this change of polarity, the direction of the current flow in the circuit also changes. During the time  $0 - T/2$ , it flows in one direction and during the interval  $T/2 - T$  in opposite direction (Fig. 16.1 a,b). This time interval  $T$



during which the voltage source changes its polarity once is known as period  $T$  of the alternating current or voltage. Thus an alternating quantity is associated with a frequency  $f$  given by

$$f = \frac{1}{T} \quad \dots\dots\dots (16.1)$$

The most common source of alternating voltage is an A.C. generator which has been described in the previous chapter. The output  $V$  of this A.C. generator at any instant is given by

$$V = V_0 \sin \frac{2\pi}{T} \times t \quad \dots\dots\dots (16.2)$$

where  $T$  is period of the rotation of the coil and is equal to the period of A.C. and  $\frac{2\pi}{T} = 2\pi f = \omega$  is angular frequency of rotation of the coil. Thus  $\frac{2\pi}{T} \times t = \omega t$  is the angle  $\theta$  through which the coil rotates in time  $t$ . Eq.16.2 shows that the value of alternating voltage  $V$  is not constant. It changes with time  $t$ .

When  $t = 0$ ,  $\theta = \frac{2\pi}{T} \times t$  is 0 and  $V$  is zero. When  $t = T/4$ ,

$$\theta = \frac{2\pi}{T} \times \frac{T}{4} = \frac{\pi}{2} \text{ and } V \text{ attains its maximum value } V_0 \text{ at this instant.}$$

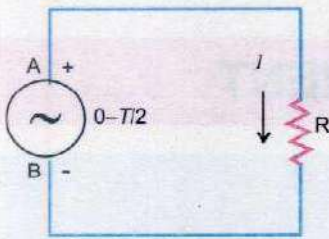
At  $t = T/2$ ,  $\theta = \pi$  and  $V$  is zero. At this instant  $V$  changes its polarity and becomes negative henceforth.

When  $t = \frac{3T}{4}$ ,  $\theta = \frac{3\pi}{2}$  and  $V = -V_0$  and finally at the end of the

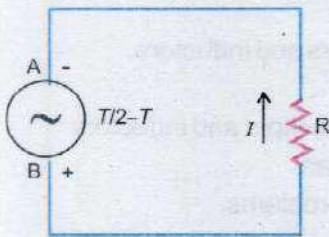
cycle when  $t = T$ ,  $\theta = 2\pi$  and  $V = 0$ . The variation of  $V$  with time  $t$  and  $\theta$  is shown in Fig. 16.2 (a,b). This graph between voltage and time is known as waveform of alternating voltage. It can be seen that it is a sine curve. Thus the output voltage of an A.C. generator varies sinusoidally with time. In our daily life we are mostly dealing with this type of voltage, so we will consider it in detail.

### 1. Instantaneous value

The value of voltage or current that exists in a circuit at any instant of time  $t$  measured from some reference point is known as its instantaneous value. It can have any value between plus maximum value  $+V_0$  and negative maximum

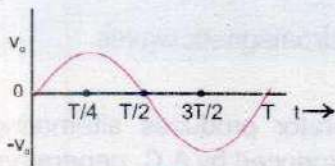


(a)

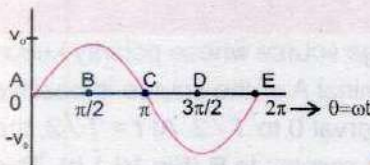


(b)

Fig. 16.1



(a)



(b)

Fig. 16.2



value  $-V_o$  and is denoted by  $V$ . The entire waveform shown in Fig. 16.2 is actually a set of all the instantaneous values that exist during a period  $T$ . Mathematically, it is given by  $V = V_o \sin \theta = V_o \sin \omega t$

$$V = V_o \sin \frac{2\pi}{T} \times t = V_o \sin 2\pi ft \quad \dots\dots\dots (16.3)$$

## 2. Peak value

It is the highest value reached by the voltage or current in one cycle. For example, voltage shown in Fig. 16.2 has a peak value of  $V_o$ .

## 3. Peak to Peak Value

It is the sum of the positive and negative peak values usually written as p-p value. The p-p value of the voltage waveform shown in Fig. 16.2 is  $2V_o$ .

## 4. Root Mean Square (rms) Value

If we connect an ordinary D.C. ammeter to measure alternating current, it would measure its value as averaged over a cycle. It can be seen in Fig. 16.2 that the average value of current and voltage over a cycle is zero, but the power delivered during a cycle is not zero because power is  $I^2R$  and the values of  $I^2$  are positive even for negative values of  $I$ . Thus the average value of  $I^2$  is not zero and is called the mean square current. The alternating current or voltage is actually measured by square root of its mean square value known as root mean square (rms) value.

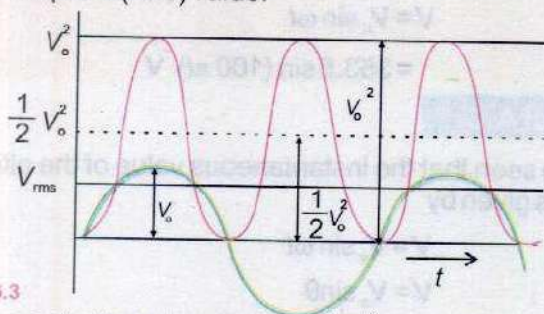
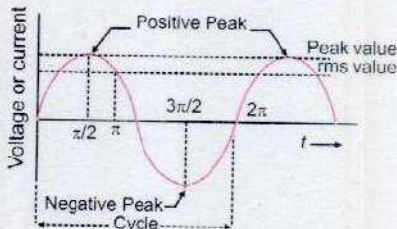


Fig. 16.3

Let us compute the average value of  $V^2$  over a cycle. Fig. 16.3 shows an alternating voltage and the way its  $V^2$  values vary. Note that the values of  $V^2$  are positive on the negative half cycle also. As the graph of  $V^2$  is symmetrical about the line  $\frac{1}{2} V_o^2$ , so for this figure the mean or the average value of  $V^2$  is  $\frac{1}{2} V_o^2$ . The root mean square value of  $V$  is obtained by taking

## Do You Know?



$$V_{rms} = 0.7 V_o$$

$$I_{rms} = 0.7 I_o$$

A.C. Waveform



the square root of  $V_o^2 / 2$ . Therefore,

$$V_{\text{rms}} = \sqrt{\frac{V_o^2}{2}} = \frac{V_o}{\sqrt{2}} = 0.7 V_o \dots\dots\dots (16.4)$$

Similarly  $I_{\text{rms}} = \frac{I_o}{\sqrt{2}} = 0.7 I_o$

Most of the alternating current and voltage meters are calibrated to read rms values. When we speak of A.C. meter reading, we usually mean rms values unless stated otherwise.

**Example 16.1 :** An A.C. voltmeter reads 250 V. What is its peak and instantaneous values if the frequency of alternating voltage is 50 Hz?

**Solution:**

rms value of alternating voltage =  $V_{\text{rms}} = 250 \text{ V}$

Its peak value  $V_o$  is given by the relation

$$V_{\text{rms}} = \frac{V_o}{\sqrt{2}}$$

or  $V_o = \sqrt{2} V_{\text{rms}} = \sqrt{2} \times 250 \text{ V} = 353.5 \text{ V}$

Angular frequency  $\omega = 2\pi f$

$$= 2 \times \pi \times 50 \text{ Hz} = 100 \pi \text{ Hz}$$

Therefore, instantaneous value is given by

$$V = V_o \sin \omega t$$

$$= 353.5 \sin (100 \pi t) \text{ V}$$

### Phase of A.C.

We have seen that the instantaneous value of the alternating voltage is given by

$$V = V_o \sin \omega t$$

or  $V = V_o \sin \theta$

This angle  $\theta$  which specifies the instantaneous value of the alternating voltage or current is known as its phase. In Fig. 16.2 (b), we can say that the phase at the points A, B, C, D and E is  $0, \pi / 2, \pi, 3\pi / 2$  and  $2\pi$  respectively because these angles are the values of  $\theta$  at these points. Thus each point on the A.C. waveform corresponds to a certain phase.



The phase at the positive peak is  $\pi/2 = 90^\circ$  and it is  $3\pi/2 = 270^\circ$  at the negative peak. The points where the waveform crosses the time axis correspond to phase 0 and  $\pi$ .

### Phase Lag and Phase Lead

In practice, the phase difference between two alternating quantities is more important than their absolute phases. Fig. 16.4 shows two waveforms 1 and 2. The phase angles of the waveform 1 at the points A, B, C, D and E have been shown above the axis and those of waveform 2 below the axis. At the point B, the phase of 1 is  $\pi/2$  and that of 2 is 0. Similarly it can be seen that at each point the phase of waveform 2 is less than the phase of waveform 1 by an angle of  $\pi/2$ . We say that A.C. 2 is lagging behind A.C. 1 by an angle of  $\pi/2$ . It means that at each instant, the phase of A.C. 2 is less than the phase of A.C. 1 by  $\pi/2$ . Similarly it can be seen in Fig. 16.5, that the phase at each point of the waveform of A.C. 2 is greater than that of waveform 1 by an angle  $\pi/2$ . In this case, it is said that A.C. 2 is leading the A.C. 1 by  $\pi/2$ . It means that at each instant of time, the phase of A.C. 2 is greater than that of 1 by  $\pi/2$ .

Phase lead and lag between two alternating quantities is conveniently shown by representing the two A.C. quantities as vectors.

### Vector Representation of an Alternating Quantity

A sinusoidally alternating voltage or current can be graphically represented by a counter clockwise rotating vector provided it satisfies the following conditions.

1. Its length on a certain scale represents the peak or rms value of the alternating quantity.
2. It is in the horizontal position at the instant when the alternating quantity is zero and is increasing positively.
3. The angular frequency of the rotating vector is the same as the angular frequency  $\omega$  of the alternating quantity.

Fig. 16.6 (a) shows a sinusoidal voltage waveform leading an alternating current waveform by  $\pi/2$ . The same fact has been shown vectorially in Fig. 16.6 (b). Here vector **OI** represents the peak or rms value of the current which is taken as the reference quantity. Similarly **OV** represents the rms or peak value of the alternating voltage which is leading the current by  $90^\circ$ . Both vectors are supposed to be rotating in the counter

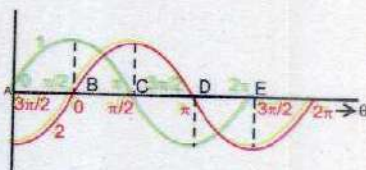


Fig. 16.4

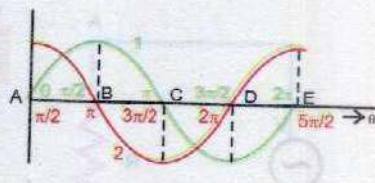
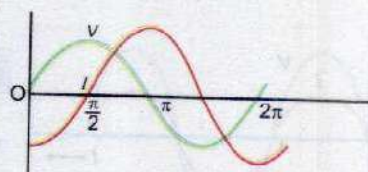
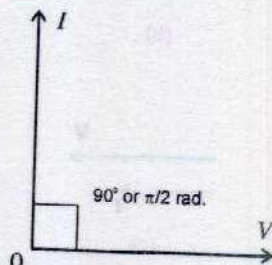


Fig. 16.5



(a)



(b)

Fig. 16.6



clockwise direction at the angular frequency  $\omega$  of the two alternating quantities. Fig. 16.6 (b) shows the position of voltage and current vector at  $t = 0$ .

## 16.2 A.C. CIRCUITS

The basic circuit element in a D.C. circuit is a resistor ( $R$ ) which controls the current or voltage and the relationship between them is given by Ohm's law that is  $V = IR$ .

In A.C. circuits, in addition to resistor  $R$ , two new circuit elements namely INDUCTOR ( $L$ ), and CAPACITOR ( $C$ ) become relevant. The current and voltages in A.C. circuits are controlled by three elements  $R$ ,  $L$  and  $C$ . We would study the response of an A.C. circuit when it is excited by an alternating voltage.

## 16.3 A.C. THROUGH A RESISTOR

Fig. 16.7 (a) shows a resistor of resistance  $R$  connected with an alternating voltage source.

At any time  $t$  the potential difference across the terminals of the resistor is given by

$$V = V_o \sin \omega t \quad \dots \dots \dots (16.5)$$

where  $V_o$  is the peak value of the alternating voltage. The current  $I$  flowing through the circuit is given by Ohm's law

$$I = \frac{V}{R} = \frac{V_o}{R} \sin \omega t$$

or 
$$I = I_o \sin \omega t \quad \dots \dots \dots (16.6)$$

where  $I$  is the instantaneous current and  $I_o = \frac{V_o}{R}$  is the

peak value of the current. It follows from Eqs. 16.5 and 16.6 that the instantaneous values of both voltage and current are sine functions which vary with time (Fig. 16.7b). This figure shows that when voltage rises, the current also rises. If the voltage falls, the current also does so – both pass their maximum and minimum values at the same instant. Thus in a purely resistive A.C. circuit, instantaneous values of voltage and current are in phase. This behaviour is shown graphically in Fig. 16.7 (b) and vectorially in Fig. 16.7 (c).

Fig. 16.7 (c) shows  $\mathbf{V}$  and  $\mathbf{I}$  vectors for resistance. They are drawn parallel because there is no phase difference between them. The opposition to A.C. which the circuit

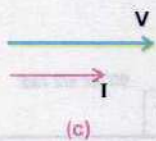
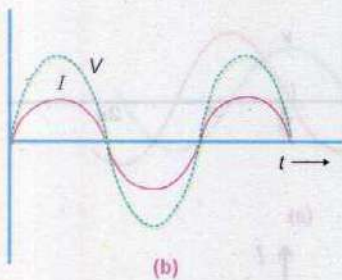
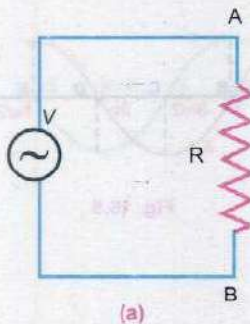


Fig. 16.7



presents is the resistance

$$R = \frac{V}{I} \quad \dots \dots \dots (16.7)$$

The instantaneous power in the resistance is given by

$$P = I^2 R = VI = V^2 / R \quad \dots \dots \dots (16.8)$$

$P$  is in watts,  $V$  is in volts,  $I$  is in amperes and  $R$  is in ohms. It is very important to note that the Eq. 16.8 holds only when the current and voltage are in phase.

### 16.4 A.C. THROUGH A CAPACITOR

Alternating current can flow through a resistor, but it is not obvious that how it can flow through a capacitor. This can be demonstrated by the circuit shown in Fig. 16.8. A low power bulb is connected in series with a  $1 \mu\text{F}$  capacitor to supply mains through a switch. When the switch is closed, the bulb lights up showing that the current is flowing through the capacitor. Direct current cannot flow through a capacitor continuously because of the presence of an insulating medium between the plates of the capacitor. Now let us see how does A.C. flows through a capacitor. The current flows because the capacitor plates are continuously charged, discharged and charged the other way round by the alternating voltage (Fig. 16.9 a). The basic relation between the charge  $q$  on a capacitor and the voltage  $V$  across its plates i.e.  $q = CV$  holds at every instant. If  $V = V_0 \sin \omega t$  is the applied alternating voltage, the charge on the capacitor at any instant will be given by

$$q = CV = CV_0 \sin \omega t \quad \dots \dots \dots (16.9)$$

Since  $C, V_0$  are constants, it is obvious that  $q$  will vary the same way as applied voltage i.e.,  $V$  and  $q$  are in phase (Fig. 16.9 b).

The current  $I$  is the rate of change of  $q$  with time i.e.,

$$I = \frac{\Delta q}{\Delta t}$$

So the value of  $I$  at any instant is the corresponding slope of the  $q-t$  curve. At  $O$  when  $\Delta q = 0$ , the slope is maximum, so  $I$  is then a maximum. From  $O$  to  $A$ , slope of the  $q-t$  curve decreases to zero. So  $I$  is zero at  $N$ . From  $A$  to  $B$  the slope of the  $q-t$  curve is negative and so  $I$  is negative from  $N$  to  $R$ . In this way the curve  $PNRST$  gives the variation of current with time.

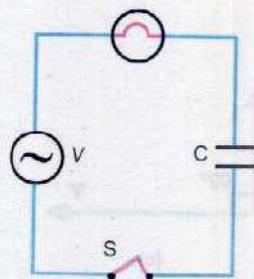
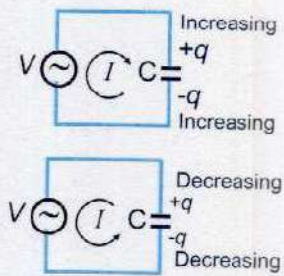
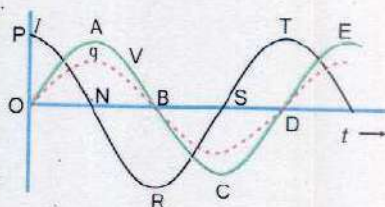


Fig. 16.8



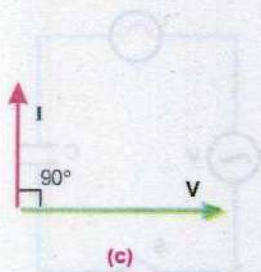
(a)



(b)

Fig. 16.9





(c)  
Fig 16.9

Referring to the Fig. 16.2 (b) it can be seen that the phase at O is zero and the phase at the upper maximum is  $\pi / 2$ . So in Fig. 16.9 (b) the phase of V at O is zero but the current at this point is maximum so its phase is  $\pi / 2$ . Thus, the current is leading the applied voltage by  $90^\circ$  or  $\pi / 2$ . Now consider the points A and N. The phase of alternating voltage at A is  $\pi / 2$  but the phase of current at N is  $\pi$ . Again the current is leading the voltage by  $90^\circ$  or  $\pi / 2$ . Similarly by comparing the phase at the pair of points (B, R), (C, S) and (D, T) it can be seen that at all these points the current leads the voltage by  $90^\circ$  or  $\pi / 2$ . This is vectorially represented in Fig. 16.9 (c).

Reactance of a capacitor is a measure of the opposition offered by the capacitor to the flow of A.C. It is usually represented by  $X_C$ . Its value is given by

$$X_C = \frac{V_{\text{rms}}}{I_{\text{rms}}} \quad \dots\dots\dots (16.10)$$

where  $V_{\text{rms}}$  is the rms value of the alternating voltage across the capacitor and  $I_{\text{rms}}$  is the rms value of current passing through the capacitor. The unit of reactance is ohm. In case of capacitor

$$X_C = \frac{1}{2\pi fC} = \frac{1}{\omega C} \quad \dots\dots\dots (16.11)$$

According to Eq. 16.11, a certain capacitor will have a large reactance at low frequency. So the magnitude of the opposition offered by it will be large and the current in the circuit will be small. On the other hand at high frequency, the reactance will be low and the high frequency current through the same capacitor will be large.

**Example 16.2:** A  $100 \mu\text{F}$  capacitor is connected to an alternating voltage of 24 V and frequency 50 Hz. Calculate

- (a) The reactance of the capacitor, and
- (b) The current in the circuit

**Solution:**

$$\begin{aligned} \text{(a) Reactance of the capacitor } X_C &= \frac{1}{2\pi fC} \\ &= \frac{1}{2 \times 3.14 \times 50 \text{ s}^{-1} \times 100 \times 10^{-6} \text{ F}} \\ X_C &= 31.8 \frac{\text{V}}{\text{C s}^{-1}} = 31.8 \Omega \end{aligned}$$



(b) From the equation  $X_C = \frac{V_{rms}}{I_{rms}}$

or 
$$I_{rms} = \frac{V_{rms}}{X_C} = \frac{24\text{ V}}{31.8\ \Omega} = 0.75\text{ A}$$

## 16.5 A.C. THROUGH AN INDUCTOR

An inductor is usually in the form of a coil or a solenoid wound from a thick wire so that it has a large value of self inductance and has a negligible resistance. We have already seen how self inductance opposes changes of current. So when an alternating source of voltage is applied across an inductor, it must oppose the flow of A.C. which is continuously changing (Fig. 16.10). Let us assume that the resistance of the coil is negligible. We can simplify the theory by considering first, the current and then finding the potential difference across the inductor which will cause this current. Suppose the current is  $I = I_0 \sin 2\pi ft$ . If  $L$  is the inductance of the coil, the changing current sets up a back emf in the coil of magnitude

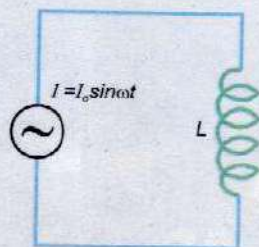
$$\varepsilon_L = L \frac{\Delta I}{\Delta t}$$

To maintain the current, the applied voltage must be equal to the back e.m.f. The applied voltage across the coil must, therefore, be equal to

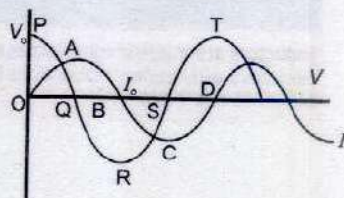
$$V = L \frac{\Delta I}{\Delta t}$$

Since  $L$  is a constant,  $V$  is proportional to  $\frac{\Delta I}{\Delta t}$ . Fig. 16.10 (b)

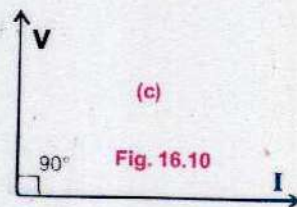
shows how the current  $I$  varies with time. The value of  $\Delta I / \Delta t$  is given by the slope of the  $I - t$  curve at the various instants of time. At  $O$ , the value of the slope is maximum, so the maximum value of  $V$  equal to  $V_0$  occurs at  $O$  and is represented by  $OP$  (Fig. 16.10 b). From  $O$  to  $A$  the slope of  $I - t$  graph decreases to zero so the voltage decreases from  $V_0$  to zero at  $Q$ . From  $A$  to  $B$ , the slope of the  $I - t$  graph is negative, so the voltage curve goes from  $Q$  to  $R$ . In this way the voltage is represented by the curve  $PQRST$  corresponding to current curve  $OABCD$ . By comparing the phases of the pair of points ( $O, P$ ), ( $A, Q$ ), ( $B, R$ ), ( $C, S$ ) and ( $D, T$ ), it can be seen that the phase of the current is always less than the phase of voltage by  $90^\circ$  or  $\pi/2$  i.e., current lags behind the applied voltage by  $90^\circ$  or  $\pi/2$  or the applied voltage leads the current by  $90^\circ$  or  $\pi/2$ .



(a)



(b)



(c)



This is vectorially shown in Fig. 16.10(c) Inductive reactance is a measure of the opposition offered by the inductance coil to the flow of A.C. It is usually denoted by  $X_L$ .

$$X_L = \frac{V_{rms}}{I_{rms}} \dots\dots\dots (16.12)$$

If  $V_{rms}$  is rms value of the alternating voltage across an inductance and  $I_{rms}$ , the rms value of the current passing through it, the value of  $X_L$  is given by

$$X_L = \frac{V_{rms}}{I_{rms}} = 2\pi fL = \omega L \dots\dots\dots (16.13)$$

The reactance of a coil, therefore, depends upon the frequency of the A.C. and the inductance  $L$ . It is directly proportional to both  $f$  and  $L$ .  $L$  is expressed in henry,  $f$  in hertz, and  $X_L$  in ohms. It is to be noted that inductance and capacitance behave oppositely as a function of frequency. If  $f$  is low  $X_L$  is small but  $X_C$  is large. For high  $f$ ,  $X_L$  is large but  $X_C$  is small. The behaviour of resistance is independent of frequency.

Referring to Fig.16.10 (b), it can be seen that no power is dissipated in a pure inductor. In the first quarter of cycle both  $V$  and  $I$  are positive so the power is positive, which means energy is supplied to inductor. In the second quarter,  $V$  is positive but  $I$  is negative. Now power is negative which implies that energy is returned by the inductor. Again in third quarter, it receives energy but returns the same amount in the fourth quarter. Thus, there is no net change of energy in a complete cycle. Since an inductor coil does not consume energy, the coil is often employed for controlling A.C. without consumption of energy. Such an inductance coil is known as choke.

## 16.6 IMPEDANCE

We already know that resistance  $R$  offers opposition to the flow of current. In case of A.C. an inductance  $L$  or a capacitance  $C$  also offer opposition to the flow of A.C. which is measured by reactances  $X_L$  and  $X_C$  respectively. An A.C. circuit may consist of a resistance  $R$ , an inductance  $L$ , a capacitance  $C$  or a combination of these elements. The combined effect of resistance and reactances in such a circuit is known as impedance and is denoted by  $Z$ .

It is measured by the ratio of the rms value of the applied voltage to the rms value of resulting A.C. Thus

$$Z = \frac{V_{rms}}{I_{rms}} \dots\dots\dots (16.14)$$

### Interesting Information



Inductors are made in many sizes to perform a wide variety of functions in business and industry.



It is also expressed in ohms.

**Example 16.3:** When 10 V are applied to an A.C. circuit, the current flowing in it is 100 mA. Find its impedance.

**Solution:**

$$\text{rms value of applied voltage} = V_{\text{rms}} = 10 \text{ V}$$

$$\text{rms value of current} = I_{\text{rms}} = 100 \text{ mA} = 100 \times 10^{-3} \text{ A}$$

$$\text{Impedance } Z = \frac{V_{\text{rms}}}{I_{\text{rms}}} = \frac{10 \text{ V}}{100 \times 10^{-3} \text{ A}} = 100 \Omega$$

## 16.7 R-C AND R-L SERIES CIRCUITS

Consider a series network of resistance  $R$  and a capacitor  $C$  excited by an alternating voltage (Fig. 16.11 a). As  $R$  and  $C$  are in series, the same current would flow through each of them. If  $I_{\text{rms}}$  is the value of current, the potential difference across the resistance  $R$  would be  $I_{\text{rms}} R$  and it would be in phase with current  $I_{\text{rms}}$ . The vector diagram of the voltage and current is shown in Fig. 16.11 (b). Taking the current as reference, the potential difference  $I_{\text{rms}} R$  across the resistance is represented by a line along the current line because potential drop  $I_{\text{rms}} R$  is in phase with current. The potential difference across the capacitor will be  $I_{\text{rms}} X_C = I_{\text{rms}} / \omega C$ . As this voltage lags the current by  $90^\circ$ , so the line representing the vector  $I_{\text{rms}} / \omega C$  is drawn at right angles to the current line (Fig. 16.11 b).

The applied voltage  $V_{\text{rms}}$  that will send the current  $I$  in the circuit is obtained by the resultant of the vectors  $I_{\text{rms}} R$  and

$$\frac{I_{\text{rms}}}{\omega C} \text{ i.e.,}$$

$$V_{\text{rms}} = \sqrt{(I_{\text{rms}} R)^2 + \left(\frac{I_{\text{rms}}}{\omega C}\right)^2}$$

$$V_{\text{rms}} = I_{\text{rms}} \sqrt{R^2 + \left(\frac{1}{\omega C}\right)^2}$$

$$\text{Impedance } Z = \frac{V_{\text{rms}}}{I_{\text{rms}}} = \sqrt{R^2 + \frac{1}{(\omega C)^2}} \dots \dots \dots (16.15)$$

It can be seen in Fig. 16.11 (b) that the current and the applied voltage are not in phase. The current leads the applied voltage by an angle  $\theta$  such that

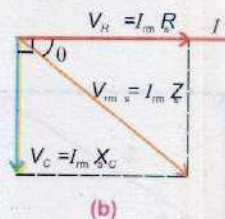
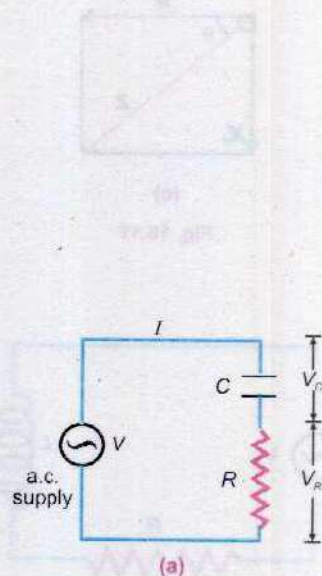
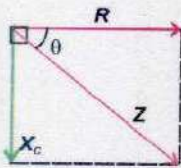


Fig 16.11



$$\theta = \tan^{-1} \left( \frac{1}{\omega CR} \right) \dots \dots \dots (16.16)$$

Eq.16.15 suggests that we can find the impedance of a series A.C. circuit by vector addition. The resistance  $R$  is represented by a horizontal line in the direction of current which is taken as reference. The reactance  $X_C = \frac{I}{\omega C}$  is



(c)  
Fig. 16.11

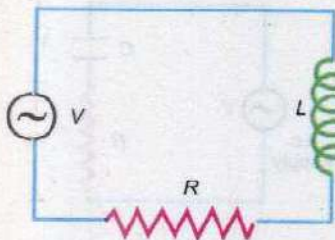
shown by a line lagging the  $R$  - line by  $90^\circ$  (Fig.16.11 c). The impedance  $Z$  of the circuit is obtained by the vector summation of resistance and reactance. Fig.16.11 (c) is known as impedance diagram of the circuit. The angle which the line representing the impedance  $Z$  makes with  $R$  line gives the phase difference between the voltage and current. In Fig.16.11(c), the current is leading the voltage applied by an angle

$$\theta = \tan^{-1} \left( \frac{X_C}{R} \right) = \tan^{-1} \left( \frac{1}{\omega CR} \right)$$

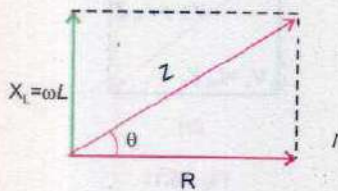
Now we will calculate the impedance of a  $R - L$  series circuit by drawing its impedance diagram. Fig.16.12 (a) shows an  $R-L$  series circuit excited by an A.C. source of frequency  $\omega$ . The current is taken as reference, so it is represented by a horizontal line. Resistance  $R$  is drawn along this line because the potential drop  $I_{rms} R$  is in phase with current. As the potential across the inductance  $V_L = I_{rms} X_L = I_{rms} (\omega L)$  leads the current by  $90^\circ$ , so the vector line of reactance  $X_L = \omega L$  is drawn at right angle to  $R$  line (Fig.16.12 b). The impedance  $Z$  of the circuit is obtained by the vector sum of  $R$  and  $\omega L$  lines. Thus

$$Z = \sqrt{R^2 + (\omega L)^2}$$

The angle  $\theta = \tan^{-1} \frac{\omega L}{R}$  which  $Z$  makes with  $R$  line gives the phase difference between the applied voltage and current. In this case the voltage leads the current by  $\theta^\circ$ . By comparing the impedance diagrams of  $R - C$  and  $L - R$  circuits, it can be seen that the vector lines of reactances  $X_C$  and  $X_L$  are directed opposite to each other with  $R$  as reference.



(a)



(b)  
Fig 16.12

## 16.8 POWER IN A.C. CIRCUITS

The expression for power is  $P = V_{rms} I_{rms}$ . This expression is true in case of A.C. circuits, only when  $V$  and  $I$  are in phase as in



case of a purely resistive circuit. We have already seen that the power dissipation in a pure inductive or in a pure capacitance circuit is zero. In these cases the current lags or leads the applied voltage by  $90^\circ$  and component of applied voltage vector  $\mathbf{V}$  along the current vector is zero (Fig.16.9 c and 16.10 c). In A.C. circuit the phase difference between applied voltage  $V$  and the current  $I_{\text{rms}}$  is  $\theta$  (Fig.16.11 b and 16.12 b). The component of  $\mathbf{V}$  along current  $I_{\text{rms}}$  is  $V_{\text{rms}} \cos\theta$ . Actually it is this component of voltage vector which is in phase with current. So the power dissipated in A.C. circuit

$$P = I_{\text{rms}} \times V_{\text{rms}} \cos\theta \quad \dots\dots\dots (16.17)$$

The factor  $\cos\theta$  is known as power factor.

**Example 16.4:** At what frequency will an inductor of 1.0 H have a reactance of 500  $\Omega$ ?

**Solution:**

$$L = 1.0 \text{ H} \quad , \quad X_L = 500 \Omega$$

$$X_L = \omega L = 2\pi fL = 500 \Omega$$

$$f = \frac{500 \Omega}{2\pi L} = \frac{500 \Omega}{2\pi \times 1.0 \text{ H}} = 80 \text{ Hz}$$

**Example 16.5:** An iron core coil of 2.0 H and 50  $\Omega$  is placed in series with a resistance of 450  $\Omega$ . An A.C. supply of 100 V, 50 Hz is connected across the circuit. Find (i) the current flowing in the coil, (ii) phase angle between the current and voltage.

**Solution:**

Resistance =  $R = 50 \Omega + 450 \Omega = 500 \Omega$

Inductance =  $L = 2.0 \text{ H}$

Supply voltage =  $V_{\text{rms}} = 100 \text{ V}$

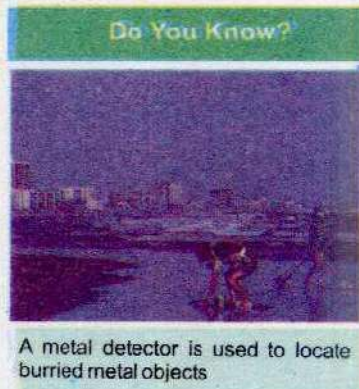
Frequency =  $f = 50 \text{ Hz}$

The reactance =  $X_L = \omega L = 2\pi fL$   
 $= 2 \times 3.14 \times 50 \text{ s}^{-1} \times 2.0 \text{ H} = 628 \Omega$

Impedance =  $Z = \sqrt{R^2 + (\omega L)^2}$   
 $= \sqrt{(500 \Omega)^2 + (628 \Omega)^2} = 803 \Omega$

Current  $I_{\text{rms}} = \frac{V_{\text{rms}}}{Z} = \frac{100 \text{ V}}{803 \Omega} = 0.01245 \text{ A} = 12.45 \text{ mA}$

Phase difference  $\theta = \tan^{-1} \left( \frac{\omega L}{R} \right)$



A metal detector is used to locate buried metal objects





$$= \tan^{-1} \left( \frac{628 \Omega}{500 \Omega} \right) = 51.5^\circ$$

**Example 16.6:** A circuit consists of a capacitor of  $2 \mu\text{F}$  and a resistance of  $1000 \Omega$  connected in series. An alternating voltage of  $12 \text{ V}$  and frequency  $50 \text{ Hz}$  is applied. Find (i) the current in the circuit, and (ii) the average power supplied.

**Solution:**

$$\text{Resistance} = R = 1000 \Omega$$

$$\text{Capacitance} = C = 2 \mu\text{F} = 2 \times 10^{-6} \text{ F}$$

$$\text{Frequency} = f = 50 \text{ Hz}$$

$$\text{Reactance} = X_C = \frac{1}{2\pi fC}$$

$$= \frac{1}{2 \times 3.14 \times 50 \text{ s}^{-1} \times 2 \times 10^{-6} \text{ F}} = 1592 \Omega$$

$$\text{Impedance} = Z = \sqrt{R^2 + (X_C)^2}$$

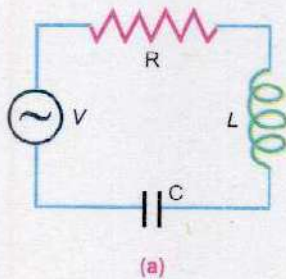
$$= \sqrt{(1000 \Omega)^2 + (1592 \Omega)^2} = 1880 \Omega$$

$$\text{Current} = I_{\text{rms}} = \frac{V_{\text{rms}}}{Z} = \frac{12 \text{ V}}{1880 \Omega} = 0.0064 \text{ A} = 6.4 \text{ mA}$$

$$\text{Phase Difference } \theta = \tan^{-1} \frac{X_C}{R} = \tan^{-1} \left( \frac{1592 \Omega}{1000 \Omega} \right) = 57.87^\circ$$

$$\text{Average power} = V_{\text{rms}} I_{\text{rms}} \cos \theta$$

$$= 12 \text{ V} \times 0.0064 \text{ A} \times 0.532 = 0.04 \text{ W}$$



## 16.9 SERIES RESONANCE CIRCUIT

Consider a  $R - L - C$  series circuit which is excited by an alternating voltage source whose frequency could be varied (Fig. 16.13 a). The impedance diagram of the circuit is shown in Fig. 16.13 (b). As explained earlier, the inductive reactance

$X_L = \omega L$  and capacitor reactance  $X_C = \frac{1}{\omega C}$  are directed

opposite to each other. When the frequency of A.C. source is very small  $X_C = \frac{1}{\omega C}$  is much greater than  $X_L = \omega L$ . So the

capacitance dominates at low frequencies and the circuit



behaves like an R - C circuit. At high frequencies  $X_L = \omega L$  is much greater than  $X_C = \frac{1}{\omega C}$ . In this case the inductance dominates and the circuit behaves like R - L circuit. In between these frequencies there will be a frequency  $\omega_r$  at which  $X_L = X_C$ . This condition is called resonance. Thus at resonance the inductive reactance being equal and opposite to capacitor reactance, cancel each other and the impedance diagram assumes the form (Fig.16.13 c). The value of the resonance frequency can be obtained by putting

$$\omega_r L = \frac{1}{\omega_r C}$$

or  $\omega_r^2 = \frac{1}{LC}$  or  $\omega_r = \frac{1}{\sqrt{LC}}$

or  $f_r = \frac{1}{2\pi\sqrt{LC}}$  ..... (16.18)

The following are the properties of the series resonance.

i) The resonance frequency is given by

$$f_r = \frac{1}{2\pi\sqrt{LC}}$$

ii) The impedance of the circuit at resonance is resistive so the current and voltage are in phase. The power factor is 1.

iii) The impedance of the circuit is minimum at this frequency and it is equal to R.

iv) If the amplitude of the source voltage  $V_o$  is constant, the current is a maximum at the resonance frequency and its value is  $V_o / R$ . The variation of current with the frequency is shown in Fig. 16.14.

v) At resonance  $V_L$ , the voltage drop across inductance and  $V_C$  the voltage drop across capacitance may be much larger than the source voltage.

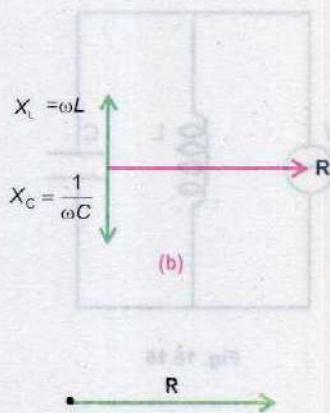


Fig. 16.13



Fig. 16.14

### 16.10 PARALLEL RESONANCE CIRCUIT

Fig. 16.15 shows an L - C parallel circuit. It is excited by an alternating source of voltage whose frequency could be varied. The inductance coil L has a resistance r which is negligibly small. The capacitor draws a leading current,



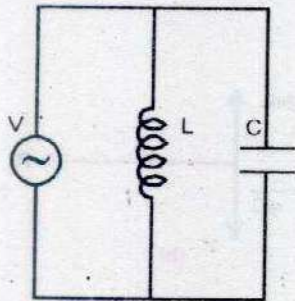


Fig. 16.15

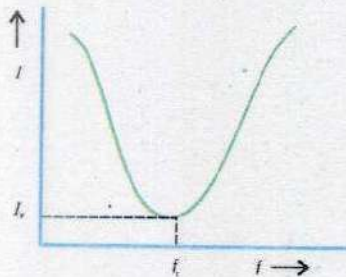


Fig. 16.16

whereas the coil draws a lagging current. The circuit resonates at a frequency  $\omega = \omega_r$ , which makes  $X_L = X_C$ , so that the two branch currents are equal but opposite. Hence, they cancel out with the result that the current drawn from the supply is zero. In actual practice, the current is not zero but has a minimum value due to small resistance  $r$  of the coil.

Properties of parallel resonant circuits are

- i) Resonance frequency is  $f_r = \frac{1}{2\pi\sqrt{LC}}$
- ii) At the resonance frequency, the circuit impedance is maximum. It is resistive.
- iii) At the resonance the current is minimum and it is in phase with the applied voltage. So the power factor is one. The variation of current with the frequency of the source is shown in Fig. 16.16.
- iv) At resonance, the branch currents  $I_L$  and  $I_C$  may each be larger than the source current  $I_r$ .

**Example 16.7:** Find the capacitance required to construct a resonance circuit of frequency 1000 kHz with an inductor of 5 mH.

**Solution:**

$$\text{Resonance frequency} = f_r = 1000 \text{ kHz}$$

$$L = 5 \text{ mH} = 5 \times 10^{-3} \text{ H}, \quad C = ?$$

$$\text{Resonance frequency} = f_r = \frac{1}{2\pi\sqrt{LC}}$$

$$C = \frac{1}{4\pi^2 f_r^2 L} = \frac{1}{4 \times (3.14)^2 \times (10^6 \text{ s}^{-1})^2 \times 5 \times 10^{-3} \text{ H}} = 5.09 \text{ pF}$$

## 16.11 THREE PHASE A.C. SUPPLY

We have already studied that an A.C. generator consists of a coil with a pair of slip rings. As the coil rotates an alternating voltage is generated across the slip rings. In a three phase A.C. generator, instead of one coil, there are three coils inclined at  $120^\circ$  to each other, each connected to its own pair of slip rings. When this combination of three coils rotate in the magnetic field, each coil generates an alternating voltage across its own pair of slip rings. Thus, three alternating voltages are generated. The phase difference between these voltages is  $120^\circ$ . It means that when voltage across the first



pair of slip rings is zero, having a phase of 0, the voltage across the second pair of slip rings would not be zero but it will have a phase of  $120^\circ$ . Similarly at this instant the voltage generated across the third pair will have a phase  $240^\circ$ . This is shown in Fig. 16.17. The machine, instead of having six terminals, two for each pair of slip rings, has only four terminals because the starting point of all the three coils has a common junction which is often earthed to the shaft of the generator and the other three ends of the coils are connected to three separate terminals on the machine. These four terminals along with the lines and coils connected to them are shown in Fig.16.18. The voltage across each of lines connected to terminals A, B, C and the neutral line is 230 V. Because of  $120^\circ$  phase shift, the voltage across any two lines is about 400 V. The main advantage of having a three phase supply is that the total load of the house or a factory is divided in three parts, so that none of the line is over loaded. If heavy load consisting of a number of air conditioners and motors etc., is supplied power from a single phase supply, its voltage is likely to drop at full load. Moreover, the three phase supply also provides 400 V which can be used to operate some special appliances requiring 400 V for their operation.

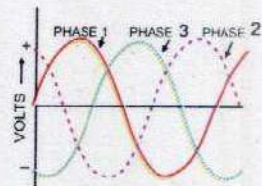


Fig. 16.17

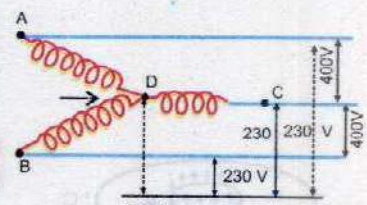


Fig. 16.18

## 16.12 PRINCIPLE OF METAL DETECTORS

A coil and a capacitor are electrical components which together can produce oscillations of current. An  $L - C$  circuit behaves just like an oscillating mass - spring system. In this case energy oscillates between a capacitor and an inductor. The circuit is called an electrical oscillator. Two such oscillators A and B are used in the operation of a common type of metal detector (Fig.16.19). In the absence of any nearby

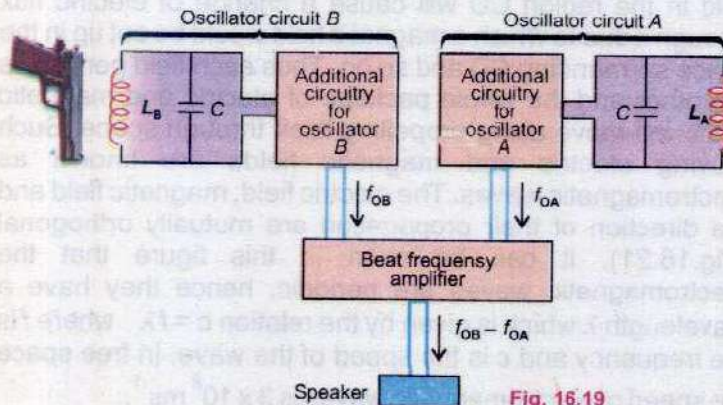


Fig. 16.19



metal object, the inductances  $L_A$  and  $L_B$  are the same and hence the resonance frequency of the two circuits is also same. When the inductor B, called the search coil comes near a metal object, its inductance  $L_B$  decreases and corresponding oscillator frequency increases and thus a beat note is heard in the attached speaker. Such detectors are extensively used not only for various security checks but also to locate buried metal objects.

### 16.13 CHOKE

It is a coil which consists of thick copper wire wound closely in a large number of turns over a soft iron laminated cores. This makes the inductance  $L$  of the coil quite large whereas its resistance  $R$  is very small. Thus it consumes extremely small power. It is used in A.C. circuits to limit current with extremely small wastage of energy as compared to a resistance or a rheostat.

### 16.14 ELECTROMAGNETIC WAVES

It is a very important class of waves which requires no medium for transmission and which rapidly propagates through vacuum.

In 1864 British physicist James Clark Maxwell formulated a set of equations known as Maxwell's equations which explained the various electromagnetic phenomena. According to these equations, a changing magnetic flux creates an electric field and a changing electric flux creates a magnetic field. Consider a region of space AB as shown in Fig.16.20. Suppose a change of magnetic flux is taking place through it. This changing magnetic flux will set up a changing electric flux in the surrounding region. The creation of electric field in the region CD will cause a change of electric flux through it due to which a magnetic field would be set up in the space surrounding CD and so on. Thus each field generates the other and the whole package of electric and magnetic fields will move along propelling itself through space. Such moving electric and magnetic fields are known as electromagnetic waves. The electric field, magnetic field and the direction of their propagation are mutually orthogonal (Fig.16.21). It can be seen  $\therefore$  this figure that the electromagnetic waves are periodic, hence they have a wavelength  $\lambda$  which is given by the relation  $c = f\lambda$  where  $f$  is the frequency and  $c$  is the speed of the wave. In free space the speed of electromagnetic waves is  $3 \times 10^8 \text{ ms}^{-1}$ .

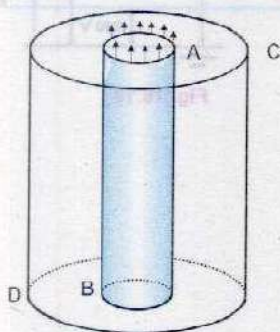


Fig 16.20



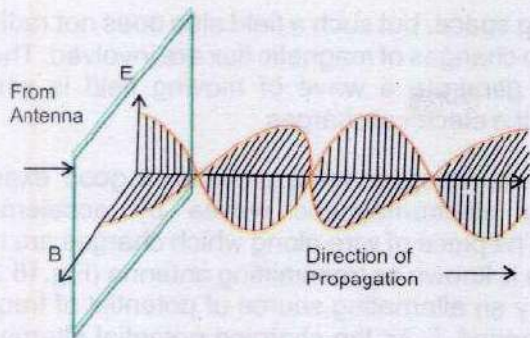


Fig. 16.21

Depending upon the values of wavelength and frequency, the electromagnetic waves have been classified into different types of waves as radiowaves, microwaves, infrared rays, visible light etc. Fig.16.22 shows the complete spectrum of

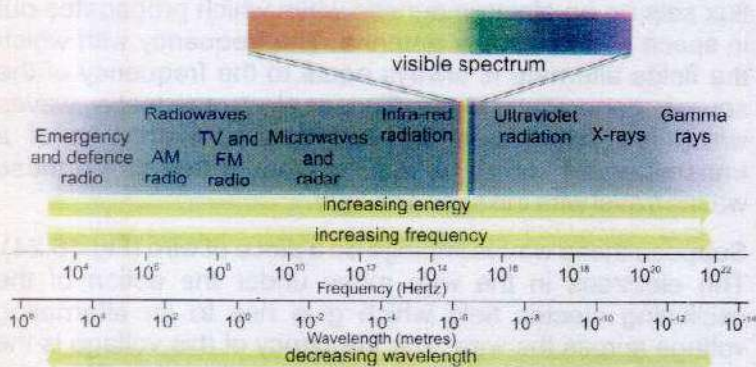


Fig. 16.22

The electromagnetic spectrum

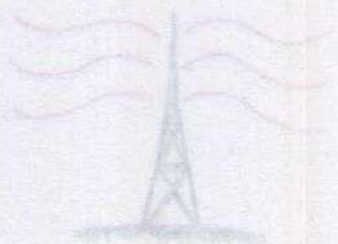
Electromagnetic waves from the low radio waves to high frequency gamma rays.

### 16.15 PRINCIPLE OF GENERATION, TRANSMISSION AND RECEPTION OF ELECTROMAGNETIC WAVES

We have seen that electromagnetic waves are generated when electric or magnetic flux is changing through a certain region of space. An electric charge at rest gives rise to a Coulomb's field which does not radiate in space because no change of flux takes place in this type of field. A charge moving with constant velocity is equivalent to a steady current which generates a constant magnetic field in the



Fig. 16.23



#### Tit-bits



Shake an electrically charged object to and fro, and you produce electromagnetic waves.



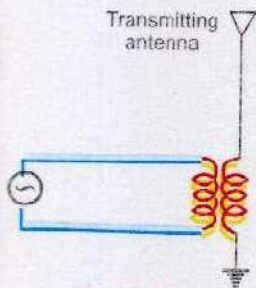
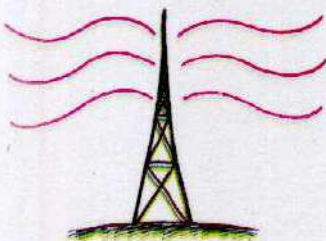


Fig. 16.23

### Do You Know?



When electrons in the transmitting antenna vibrate 94,000 times each second, they produced radio waves having frequency 94 kHz.

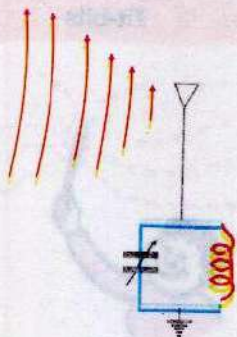


Fig. 16.24

surrounding space, but such a field also does not radiate out because no changes of magnetic flux are involved. Thus only chance to generate a wave of moving field is when we accelerate the electrical charges.

A radio transmitting antenna provides a good example of generating electromagnetic waves by acceleration of charges. The piece of wire along which charges are made to accelerate is known as transmitting antenna (Fig.16.23). It is charged by an alternating source of potential of frequency  $f$  and time period  $T$ . As the charging potential alternates, the charge on the antenna also constantly reverses. For example if the top has  $+q$  charges at any instant, then after time  $T/2$  the charge on it will be  $-q$ . Such regular reversal of charges on the antenna gives rise to an electric flux that constantly changes with frequency  $f$ . This changing electric flux sets up an electromagnetic wave which propagates out in space away from the antenna. The frequency with which the fields alternate is always equal to the frequency of the source generating them. These electromagnetic waves which are propagated out in space from antenna of a transmitter are known as radio waves. In free space these waves travel with the speed of light.

Suppose these waves impinge on a piece of wire (Fig.16.24). The electrons in the wire move under the action of the oscillating electric field which give rise to an alternating voltage across the wire. The frequency of this voltage is the same as that of the wave intercepting the wire. This wire receiving the wave is known as receiving antenna. As the electric field of the wave is very weak at a distance of many kilometres from the transmitter, the voltage that appears across the receiving antenna is very small. Each transmitter propagates radio waves of one particular frequency. So when a number of transmitting stations operate simultaneously, we have a number of radio waves of different frequencies in the space. Thus the voltage that appears across a receiving antenna placed in space is usually due to the radio waves of large number of frequencies. The voltage of one particular frequency can be picked up by connecting an inductance  $L$  and a variable capacitor  $C$  in parallel with one end of the receiving antenna (Fig.16.24).

If one adjusts the value of the capacitor so that the natural frequency of  $L - C$  circuit is the same as that of the transmitting station to be picked up, the circuit will resonate



under the driving action of the antenna. Consequently, the  $L - C$  circuit will build up a large response to the action of only that radio wave to which it is tuned. In your radio receiver set when you change stations you actually adjust the value of  $C$ .

## 16.16 MODULATION

Speech and music etc. are transmitted hundred of kilometres away by a radio transmitter. The scene in front of a television camera is also sent many kilometres away to viewers. In all these uses, the carrier of the programme is a high frequency radio wave. The information i.e., light, sound or other data is impressed on the radio wave and is carried along with it to the destination.

Modulation is the process of combining the low frequency signal with a high frequency radio wave called carrier wave. The resultant wave is called modulated carrier wave. The low frequency signal is known as modulation signal. Modulation is achieved by changing the amplitude or the frequency of the carrier wave in accordance with the modulating signal. Thus we have two types of modulations which are

1. Amplitude modulation (A.M), 2. Frequency modulation (F.M)

### Amplitude Modulation

In this type of modulation the amplitude of the carrier wave is increased or diminished as the amplitude of the superposing modulating signal increases and decreases.

Fig.16.25 (a) represents a high frequency carrier wave of constant amplitude and frequency. Fig.16.25(b) represents a low or audio frequency signal of a sine waveform. Fig.16.25 (c) shows the result obtained by modulating the carrier waves with the modulating wave. The A.M. transmission frequencies range from 540 kHz to 1600 kHz.

### Frequency Modulation

In this type of modulation the frequency of the carrier wave is increased or diminished as the modulating signal amplitude increases or decreases but the carrier wave amplitude remains constant. Fig.16.26 shows frequency modulation. The frequency of the modulated carrier wave is highest (point H) when the signal amplitude is at its maximum positive value and is at its lowest frequency (point L) when signal amplitude has maximum negative. When the signal amplitude is zero, the carrier frequency is at its normal frequency  $f_c$ .

### For Your Information

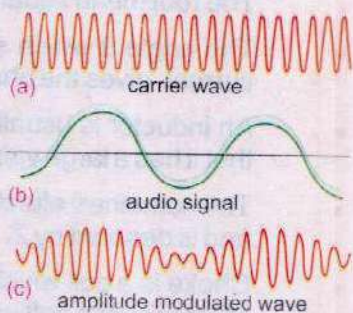
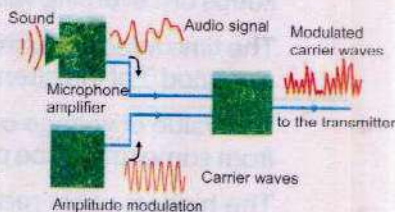


Fig. 16.25

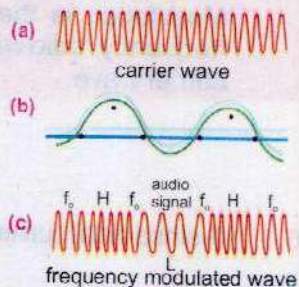


Fig. 16.26



The F.M. transmission frequencies are much higher and ranges between 88 MHz to 108 MHz. F.M. radio waves are affected less by electrical interference than A.M. radio waves and hence, provide a higher quality transmission of sound. However, they have a shorter range than A.M. waves and are less able to travel around obstacles such as hills and large buildings.

### SUMMARY

- Alternating current is that which is produced by a voltage source whose polarity keeps on reversing with time.
- The time interval during which the voltage source changes its polarity once is known as period  $T$  of the alternating current or voltage.
- The value of voltage or current that exists in a circuit at any instant of time measured from some reference point is known as its instantaneous value.
- The highest value reached by the voltage or current in one cycle is called the peak value of the voltage or current.
- The sum of positive and negative peak values is called peak to peak value and is written as p-p value.
- The root mean square value (rms) is the square root of the average value of  $V^2$  or  $I^2$ .
- The angle  $\theta$  which specifies the instantaneous value of the alternating voltage or current, gives the phase lag or phase lead of one quantity over the other.
- An inductor is usually in the form of a coil or a solenoid wound from a thick wire so that it has a large value of self inductance and has negligible resistance.
- The combined effect of resistance and reactance in a circuit is known as impedance and is denoted by  $Z$ .
- Choke is a coil which consists of thick copper wire wound closely in a large number of turns over a soft iron laminated core.
- Electromagnetic waves are those which require no medium for transmission and rapidly propagate through vacuum.
- Modulation is the process of combining the low frequency signal with a high frequency radio wave, called carrier waves. The resultant wave is called modulated carrier wave.

### QUESTIONS

- 16.1 A sinusoidal current has rms value of 10 A. What is the maximum or peak value?



- 16.2 Name the device that will (a) permit flow of direct current but oppose the flow of alternating current (b) permit flow of alternating current but not the direct current.
- 16.3 How many times per second will an incandescent lamp reach maximum brilliance when connected to a 50 Hz source?
- 16.4 A circuit contains an iron-cored inductor, a switch and a D.C. source arranged in series. The switch is closed and after an interval reopened. Explain why a spark jumps across the switch contacts?
- 16.5 How does doubling the frequency affect the reactance of (a) an inductor (b) a capacitor?
- 16.6 In a  $R - L$  circuit, will the current lag or lead the voltage? Illustrate your answer by a vector diagram.
- 16.7 A choke coil placed in series with an electric lamp in an A.C. circuit causes the lamp to become dim. Why is it so? A variable capacitor added in series in this circuit may be adjusted until the lamp glows with normal brilliance. Explain, how this is possible?
- 16.8 Explain the conditions under which electromagnetic waves are produced from a source?
- 16.9 How the reception of a particular radio station is selected on your radio set?
- 16.10 What is meant by A.M. and F.M.?

### PROBLEMS

- 16.1 An alternating current is represented by the equation  $I = 20 \sin 100 \pi t$ . Compute its frequency and the maximum and rms values of current. (Ans: 50 Hz, 20 A, 14 A)
- 16.2 A sinusoidal A.C. has a maximum value of 15 A. What are its rms values? If the time is recorded from the instant the current is zero and is becoming positive, what is the instantaneous value of the current after  $1/300$  s, given the frequency is 50 Hz. (Ans:  $I_{\text{rms}} = 10.6$  A, Instantaneous current = 13.0 A)
- 16.3 Find the value of the current and inductive reactance when A.C. voltage of 220 V at 50 Hz is passed through an inductor of 10 H. (Ans:  $I_{\text{rms}} = 0.07$  A,  $X_L = 3140 \Omega$ )
- 16.4 A circuit has an inductance of  $1/\pi$  H and resistance of 2000  $\Omega$ . A 50 Hz A.C. is supplied to it. Calculate the reactance and impedance offered by the circuit. (Ans:  $X_L = 100 \Omega$ ,  $Z = 2002.5 \Omega$ )
- 16.5 An inductor of pure inductance  $3/\pi$  H is connected in series with a resistance of 40  $\Omega$ . Find (i) the peak value of the current (ii) the rms value, and (iii) the phase difference between the current and the applied voltage  $V = 350 \sin(100\pi t)$ . (Ans: (i) 1.16 A, (ii) 0.81 A, (iii)  $82.4^\circ$ )
- 16.6 A 10 mH, 20  $\Omega$  coil is connected across 240 V and  $180/\pi$  Hz source. How much power does it dissipate? (Ans: 2778 W)



- 16.7 Find the value of the current flowing through a capacitance  $0.5 \mu\text{F}$  when connected to a source of  $150 \text{ V}$  at  $50 \text{ Hz}$ . (Ans:  $I_{\text{rms}} = 0.024 \text{ A}$ )
- 16.8 An alternating source of emf  $12 \text{ V}$  and frequency  $50 \text{ Hz}$  is applied to a capacitor of capacitance  $3 \mu\text{F}$  in series with a resistor of resistance  $1 \text{ k}\Omega$ . Calculate the phase angle. (Ans:  $46.7^\circ$ )
- 16.9 What is the resonant frequency of a circuit which includes a coil of inductance  $2.5 \text{ H}$  and a capacitance  $40 \mu\text{F}$ ? (Ans:  $15.9 \text{ Hz}$ )
- 16.10 An inductor of inductance  $150 \mu\text{H}$  is connected in parallel with a variable capacitor whose capacitance can be changed from  $500 \text{ pF}$  to  $20 \text{ pF}$ . Calculate the maximum frequency and minimum frequency for which the circuit can be tuned. (Ans:  $2.91 \text{ MHz}, 0.58 \text{ MHz}$ )



# Chapter 17

## PHYSICS OF SOLIDS

### Learning Objectives

At the end of this chapter the students will be able to:

1. Distinguish between the structure of crystalline, glassy, amorphous and polymeric solids.
2. Understand the idea of lattice.
3. Appreciate that deformation is caused by a force and that, in one dimension, the deformation can be tensile or compressive.
4. Define and use the terms Young's modulus, bulk modulus and shear modulus.
5. Describe an experiment to determine elastic limit and yield strength.
6. Distinguish between elastic and plastic deformation of a material.
7. Synthesize and deduce the strain energy in a deformed material from the area under the force extension graph.
8. Describe the energy bands in solids.
9. Classify insulators, conductors, semi-conductors on the basis of energy bands.
10. Distinguish between intrinsic and extrinsic semiconductors.
11. Explain how electrons and holes flow across a junction.
12. Describe superconductors.
13. Distinguish between dia, para and ferro magnetic materials.
14. Understand and describe the concept of magnetic domains in a material.
15. Know the Curie point.
16. Classify hard and soft ferro magnetic substances.
17. Understand hysteresis and hysteresis loss.

**M**aterials have specific uses depending upon their characteristics and properties, such as hardness, ductility, malleability, conductivity etc. What makes steel hard, lead soft, iron magnetic and copper electrically conducting? It depends upon the structure -- the particular order and bonding of atoms in a material. This clue has made it possible to design and create materials with new and unusual properties for use in modern technology.

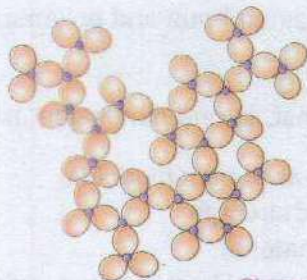
### 17.1 CLASSIFICATION OF SOLIDS

#### Crystalline Solids

In crystalline solids there is a regular arrangement of molecules. The neighbours of every molecule are arranged in a regular pattern that is constant throughout the crystal. There is, thus an ordered structure in crystalline solids.

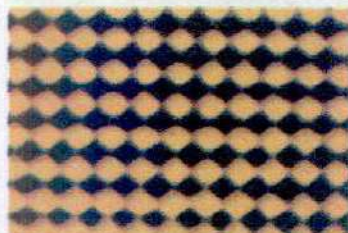


### For Your Information



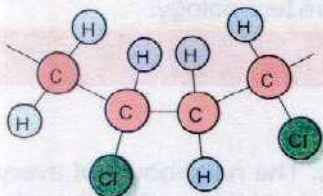
Glassy and crystalline solids—short- and long-range order.

### For Your Information



Transmission Electron Micrograph of the atomic lattice of a gold crystal.

### For Your Information



Part of a PVC molecule

The vast majority of solids, e.g., metals such as copper, iron and zinc, ionic compounds such as sodium chloride, ceramics such as zirconia are crystalline. The arrangement of molecules, atoms or ions within all types of crystalline solids can be studied using various X-ray techniques. It should be noted that atoms, molecules or ions in a crystalline solid are not static. For example, each atom in a metal crystal vibrates about a fixed point with an amplitude that increases with rise in temperature. It is the average atomic positions which are perfectly ordered over large distances.

The cohesive forces between atoms, molecules or ions in crystalline solids maintain the strict long-range order in spite of atomic vibrations. For every crystal, however, there is a temperature at which the vibrations become so great that the structure suddenly breaks up, and the solid melts. The transition from solid (order) to liquid (disorder) is, therefore, abrupt or discontinuous. Every crystalline solid has a definite melting point.

## Amorphous or Glassy Solids

The word amorphous means without form or structure. Thus in amorphous solids there is no regular arrangement of molecules like that in crystalline solids. We can, therefore, say that amorphous solids are more like liquids with the disordered structure frozen in.

For example ordinary glass, which is a solid at ordinary temperature, has no regular arrangement of molecules. On heating, it gradually softens into a paste like state before it becomes a very viscous liquid at almost 800°C. Thus amorphous solids are also called glassy solids. This type of solids have no definite melting point.

## Polymeric Solids

Polymers may be said to be more or less solid materials with a structure that is intermediate between order and disorder. They can be classified as partially or poorly crystalline solids.

Polymers form a large group of naturally occurring and synthetic materials. Plastics and synthetic rubbers are termed 'Polymers' because they are formed by polymerization reactions in which relatively simple molecules are chemically combined into massive long chain molecules, or "three dimensional" structures. These materials have rather low specific gravity compared with even the lightest of metals, and



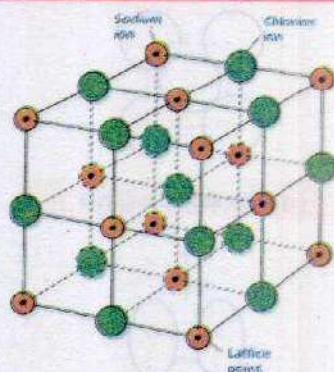
yet exhibit good strength-to-weight ratio.

Polymers consist wholly or in part of chemical combinations of carbon with oxygen, hydrogen, nitrogen and other metallic or non-metallic elements. Polythene, polystyrene and nylon etc., are examples of polymers. Natural rubber is composed in the pure state entirely of a hydrocarbon with the formula  $(C_5H_8)_n$ .

### Crystal Lattice

A crystalline solid consists of three dimensional pattern that repeats itself over and over again. This smallest three dimensional basic structure is called unit cell. The whole structure obtained by the repetition of unit cell is known as crystal lattice. For example, the pattern of NaCl particles have a cube shape. The cube shape of the sodium chloride is just one of several crystal shapes. In a cubic crystal all the sides meet at right angles. Other crystal shapes have corners in which one or more of the angles are not right angles.

### For Your Information



NaCl crystal lattice

## 17.2 MECHANICAL PROPERTIES OF SOLIDS

### Deformation in Solids

If we hold a soft rubber ball in our hand and then squeeze it, the shape or volume of the ball will change. However, if we stop squeezing the ball, and open our hand, the ball will return to its original spherical shape. This has been illustrated schematically in Fig. 17.1.

Similarly, if we hold two ends of a rubber string in our hands, and move our hands apart to some extent, the length of the string will increase under the action of the applied force exerted by our hands. Greater the applied force larger will be the increase in length. Now on removing the applied force, the string will return to its original length. From these examples, it is concluded that deformation (i.e., change in shape, length or volume) is produced when a body is subjected to some external force.

In crystalline solids atoms are usually arranged in a certain order. These atoms are held about their equilibrium position, which depends on the strength of the inter-atomic cohesive force between them. When external force is applied on such a body, a distortion results because of the displacement of the atoms from their equilibrium position and the body is said to be in a state of stress. After the removal of external force,

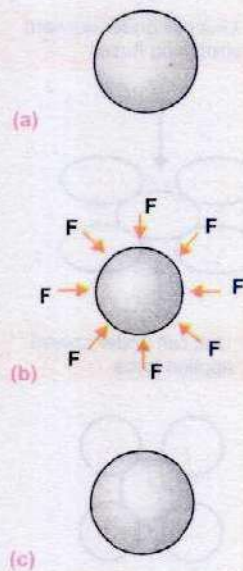


Fig 17.1

- (a) Original rubber ball
- (b) Squeezed rubber ball subjected force  $F$  by the hand
- (c) Rubber ball after removing force



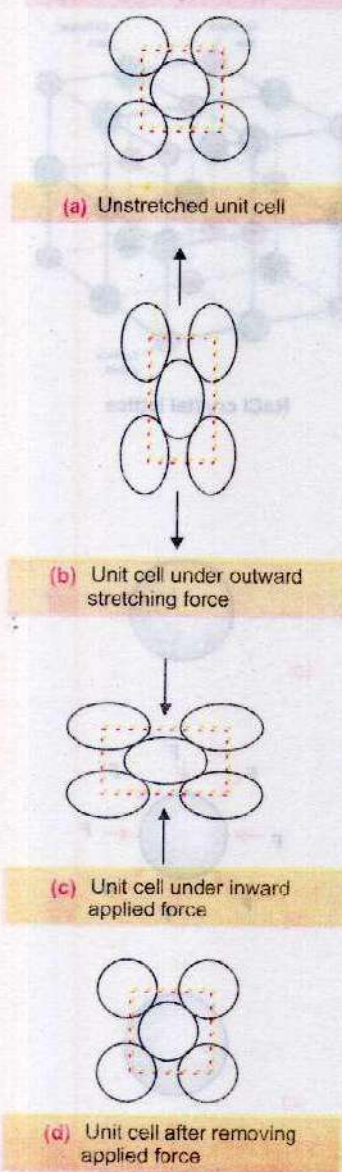


Fig. 17.2

the atoms return to their equilibrium position, and the body regains its original shape, provided that external applied force was not too great. The ability of the body to return to its original shape is called elasticity. Fig.17.2 illustrates deformation produced in a unit cell of a crystal subjected to an external applied force.

### Stress and Strain

The results of mechanical tests are usually expressed in terms of stress and strain, which are defined in terms of applied force and deformation.

#### Stress

It is defined as the force applied on unit area to produce any change in the shape, volume or length of a body. Mathematically it is expressed as

$$\text{Stress } (\sigma) = \frac{\text{Force } (F)}{\text{Area } (A)} \dots\dots\dots (17.1)$$

The SI unit of stress ( $\sigma$ ) is newton per square metre ( $\text{Nm}^{-2}$ ), which is given the name pascal (Pa).

Stress may cause a change in length, volume and shape. When a stress changes length, it is called the tensile stress, when it changes the volume it is called the volume stress and when it changes the shape it is called the shear stress.

#### Strain

Strain is a measure of the deformation of a solid when stress is applied to it. In the case of deformation in one dimension, strain is defined as the fractional change in length. If  $\Delta \ell$  is the change in length and  $\ell$  is the original length (Fig. 17.3 a), then strain is given by

$$\text{Strain } (\epsilon) = \frac{\text{Change in length } (\Delta \ell)}{\text{Original length } (\ell)} \dots\dots\dots (17.2)$$

Since strain is ratio of lengths, it is dimensionless, and therefore, has no units. If strain  $\epsilon$  is due to tensile stress  $\sigma$ , it is called tensile strain, and if it is produced as a result of compressive stress  $\sigma$ , it is termed as compressive strain.

In case when the applied stress changes the volume, the change in volume per unit volume is known as volumetric strain (Fig. 17.3 b). Thus



$$\text{Volumetric strain} = \frac{\Delta V}{V_0}$$

Now referring to Fig. 17.3 (c), when the opposite faces of a rigid cube are subjected to shear stress, the shear strain produced is given by

$$\gamma = \frac{\Delta a}{a} = \tan \theta \quad \dots \dots \dots (17.3)$$

However, for small values of angle  $\theta$ , measured in radian,  $\tan \theta = \theta$ , so that

$$\gamma = \theta \quad \dots \dots \dots (17.4)$$

### Elastic Constants

Experiments have revealed that the ratio of stress to strain is a constant for a given material, provided the external applied force is not too great. This ratio is called modulus of elasticity, and can be mathematically described as

$$\text{Modulus of Elasticity} = \frac{\text{Stress}}{\text{Strain}} \quad \dots \dots \dots (17.5)$$

Since strain is a dimensionless quantity, the units of modulus of elasticity are the same as those of stress, i.e.,  $\text{Nm}^{-2}$  or Pa.

In the case of linear deformation, the ratio of tensile (or compressive) stress  $\sigma (= F/A)$  to tensile (or compressive) strain  $\epsilon = \Delta l/l$  is called Young's modulus.

$$Y = \frac{F/A}{\Delta l/l} \quad \dots \dots \dots (17.6)$$

For three dimensional deformation, when volume is involved, then the ratio of applied stress to volumetric strain is called Bulk modulus.

$$K = \frac{F/A}{\Delta V/V} \quad \dots \dots \dots (17.7)$$

where  $\Delta V$  is the change in original volume  $V$ .

However, when the shear stress  $\tau (= F/A)$  and shear strain  $\gamma (= \tan \theta)$  are involved, then their ratio is called shear modulus.

$$G = \frac{F/A}{\tan \theta} \quad \dots \dots \dots (17.8)$$

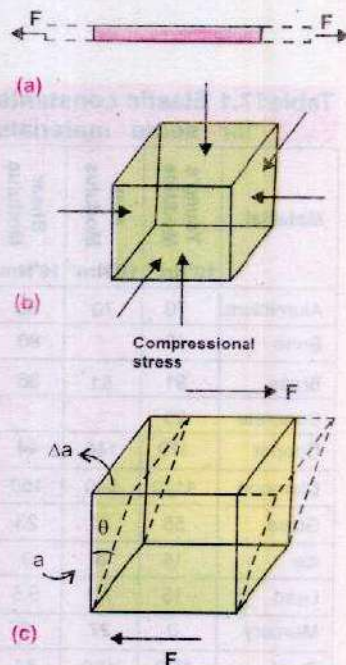
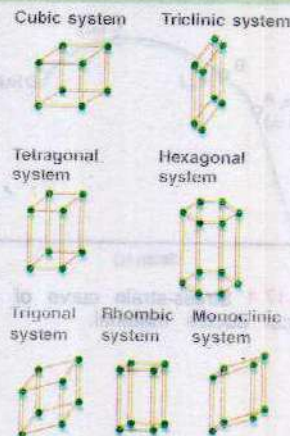


Fig. 17.3

- (a) Wire pulled along its length by stretching force  $F$ .
- (b) Cylinder subjected to compressive force  $F$ .
- (c) Cube subjected to shearing force  $F$ .

### For Your Information

There are seven different crystals systems based on the geometrical arrangement of their atoms and the resultant geometrical structures.





Elastic constants for some of the materials are given in Table 17.1.

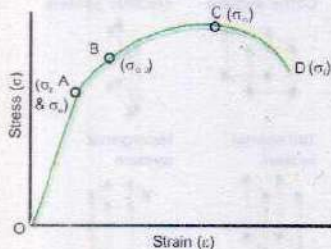
**Table 17.1 Elastic constants for some materials**

Material	Young's Modulus	Bulk Modulus	Shear Modulus
	$10^9 \text{Nm}^{-2}$	$10^9 \text{Nm}^{-2}$	$10^9 \text{Nm}^{-2}$
Aluminium	70	70	30
Bone	15	-	80
Brass	91	61	36
Concrete	25	-	-
Copper	110	140	44
Diamond	1120	540	450
Glass	55	31	23
Ice	14	8	3
Lead	15	7.7	5.6
Mercury	0	27	0
Steel	200	160	84
Tungsten	390	200	150
Water	0	2.2	0

### Elastic Limit and Yield Strength

In a tensile test, metal wire is extended at a specified deformation rate, and stresses generated in the wire during deformation are continuously measured by a suitable electronic device fitted in the mechanical testing machine. Force-elongation diagram or stress-strain curve is plotted automatically on X-Y chart recorder. A typical stress-strain curve for a ductile material is shown in Fig. 17.4.

In the initial stage of deformation, stress is increased linearly with the strain till we reach point A on the stress-strain curve. This is called proportional limit ( $\sigma_p$ ). It is defined as the greatest stress that a material can endure without losing straight line proportionality between stress and strain. Hooke's law which states that the strain is directly proportional to stress is obeyed in the region OA. From A to B, stress and strain are not proportional, but nevertheless, if the load is removed at any point between O and B, the curve will be retraced and the material will return to its original length. In the region OB, the material is said to be elastic. The point B is called the yield point. The value of stress at B is known as elastic limit  $\sigma_e$ . If the stress is increased beyond the yield stress or elastic limit of the material, the specimen becomes permanently changed and does not recover its original shape or dimension after the stress is removed. This kind of behaviour is called plasticity.



**Fig. 17.4** Stress-strain curve of a typical ductile material.

The region of plasticity is represented by the portion of the curve from B to C, the point C in Fig. 17.4 represents the ultimate tensile strength (UTS)  $\sigma_m$  of the material. The UTS is defined as the maximum stress that a material can withstand, and can be regarded as the nominal strength of the material. Once point C corresponding to UTS is crossed, the material breaks at point D, responding the fracture stress ( $\sigma_f$ ).

Substances which undergo plastic deformation until they break, are known as ductile substances. Lead, copper and wrought iron are ductile. Other substances which break just after the elastic limit is reached, are known as brittle substances. Glass and high carbon steel are brittle.

**Example 17.1:** A steel wire 12 mm in diameter is fastened



to a log and is then pulled by tractor. The length of steel wire between the log and the tractor is 11 m. A force of 10,000 N is required to pull the log. Calculate (a) the stress in the wire and (b) the strain in the wire. (c) How much does the wire stretch when the log is pulled? ( $E = 200 \times 10^9 \text{ Nm}^{-2}$ )

**Solution:**

(a) As tensile stress  $\sigma = \frac{F}{A} = \frac{10,000 \text{ N}}{3.14 \times (6 \times 10^{-3} \text{ m})^2}$   
 $= 88.46 \times 10^6 \text{ Nm}^{-2} = 88.46 \text{ MPa}$

(b) The tensile strain  $\epsilon = \frac{\Delta \ell}{\ell}$

Also  $E = \frac{\text{Stress}}{\text{Strain}} = \frac{88.46 \times 10^6 \text{ Nm}^{-2}}{\text{Strain}} = 200 \times 10^9 \text{ Nm}^{-2}$

Strain =  $\frac{88.46 \times 10^6 \text{ Nm}^{-2}}{200 \times 10^9 \text{ Nm}^{-2}} = 4.4 \times 10^{-4}$

(c) Now using the relation Strain =  $\frac{\Delta \ell}{\ell}$ , we get

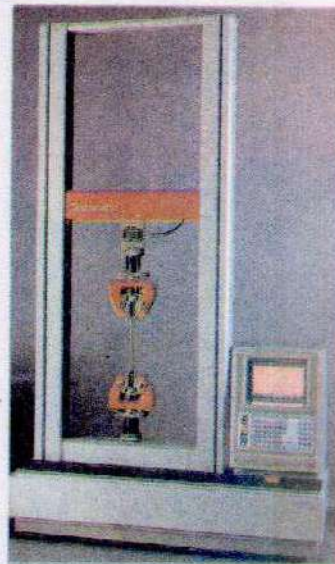
$\Delta \ell = 4.4 \times 10^{-4} \times 11 \text{ m} = 4.84 \times 10^{-3} \text{ m} = 4.84 \text{ mm}$

### Strain Energy in Deformed Materials

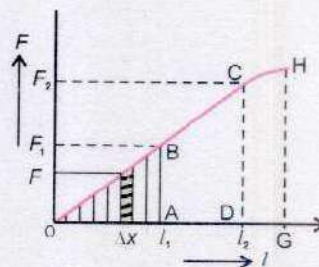
Consider a wire suspended vertically from one end. It is stretched by attaching a weight at the other end. We can increase the stretching force by increasing the weight. By noting the extension  $\ell$  of the wire for different values of the stretching force  $F$ , a graph can be drawn between the force  $F$  and the extension  $\ell$  (Fig.17.5). If the elastic limit is not exceeded, the extension is directly proportional to force  $F$ . As the force  $F$  stretches the wire, it does some amount of work on wire which is equal to product of force  $F$  and the extension  $\ell$ . Suppose we are required to find the amount of the work done when the extension is  $\ell_1$ . Let the force for this extension be  $F_1$ . Fig.17.5 shows that the force  $F$  does not remain constant in producing the extension  $\ell_1$ , it varies uniformly from 0 to  $F_1$ . In such a situation the work is calculated by graphical method.

Suppose at some stage before the extension  $\ell_1$  is reached, the force in the wire is  $F$  and that the wire now extends by a very small amount  $\Delta x$ . The extension  $\Delta x$  is so small that the force  $F$  may be assumed constant in  $\Delta x$ , so the work done in producing this small extension is  $F \times \Delta x$ . In the figure it can be

### For Your Information



This is a machine used to investigate the way the extension of a material varies with the force stretching it.



Energy in stretched wire

Fig. 17.5



seen that it is represented by the area of the shaded strip. In this way the total extension  $\ell_1$  can be divided into very small extensions and the work done during each of these small extensions would be given by the area of the strips (Fig. 17.5). So the total work done in producing the extension  $\ell_1$  is the sum area of all these strips which is equal to area between the graph and the axis on which extension has been plotted upto  $\ell = \ell_1$ . In this case it equals to area of the triangle OAB.

$$\begin{aligned} \therefore \text{Work done} &= \text{Area of } \triangle OAB \\ &= \frac{1}{2} OA \times AB \\ &= \frac{1}{2} \ell_1 \times F_1 \quad \dots\dots\dots (17.9) \end{aligned}$$

This is the amount of energy stored in the wire. It is the gain in the potential energy of the molecules due to their displacement from their mean positions. Eq.17.9 gives the energy in joules when  $F$  is in newton and  $\ell$  in metres.

Eq.17.9 can also be expressed in terms of modulus of elasticity  $E$ . If  $A$  is the area of cross-section of the wire and  $L$  its total length then

$$E = \frac{F_1}{A} \times \frac{L}{\ell_1}$$

$$\text{or } F_1 = \frac{EA \times \ell_1}{L}$$

Substituting the value of  $F$ , in Eq. 17.9 we have

$$\text{Work done} = \frac{1}{2} \left[ \frac{EA \times \ell_1^2}{L} \right] \quad \dots\dots\dots (17.10)$$

The area method is quite a general one. For example if the extension is increased from  $\ell_1$  to  $\ell_2$ , the amount of work done by the stretching force would be given by the area of the trapezium ABCD (Fig. 17.5). It is also valid for both the linear (elastic) and the non-linear (non-elastic) parts of the force-extension graph. If the extension occurs from O to G (Fig. 17.5), this work done would be the area of OHG.

### 17.3 ELECTRICAL PROPERTIES OF SOLIDS

The fundamental electrical property of a solid is its response to an applied electric field, i.e., its ability to conduct electric current. The electrical behaviours of various materials are



diverse. Some are very good conductors, e.g., metals with conductivities of the order of  $10^7 (\Omega\text{m})^{-1}$ . At the other extreme, some solids, e.g., wood, diamond etc., have very low conductivities ranging between  $10^{-10}$  and  $10^{-20} (\Omega\text{m})^{-1}$ , these are called insulators. Solids with intermediate conductivities, generally from  $10^8$  to  $10^4 (\Omega\text{m})^{-1}$ , are termed semiconductors, e.g., silicon, germanium etc. The conventional free electron theory based on Bohr model of electron distribution in an atom failed to explain completely the vast diversity in the electrical behaviour of these three types of materials.

On the other hand, energy band theory based on wave mechanical model has been found successful in resolving the problem.

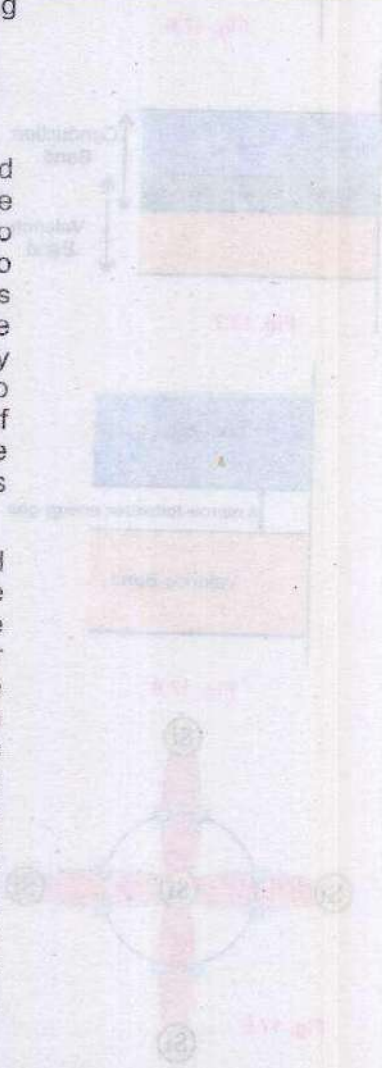
### Do You Know?

Glass is also known as solid liquid because its molecules are irregularly arranged as in a liquid but fixed in their relative positions.

## Energy Band Theory

Electrons of an isolated atom are bound to the nucleus, and can only have distinct energy levels. However, when a large number of atoms, say  $N$ , are brought close to one another to form a solid, each energy level of the isolated atom splits into  $N$  sub-levels, called states, under the action of the forces exerted by other atoms in the solid. These permissible energy states are discrete but so closely spaced that they appear to form a continuous energy band. In between two consecutive permissible energy bands, there is a range of energy states which cannot be occupied by electrons. These are called forbidden energy states, and its range is termed as forbidden energy gap.

The electrons in the outermost shell of an atom are called valence electrons and the energy band occupying these electrons is known as valence band. It is obviously the highest occupied band. It may be either completely filled or partially filled with electrons and can never be empty. The band above the valence band is called conduction band. In conduction band, electrons move freely and conduct electric current through solids. That is why the electrons occupying this band are known as conductive electrons or free electrons. Any electron leaving the valence band is accommodated by this band. It may be either empty or partially filled with electrons. The bands below the valence band are normally completely filled and as such play no part in the conduction process. Thus, while discussing the electrical conductivity we will consider only the valence and conduction bands.





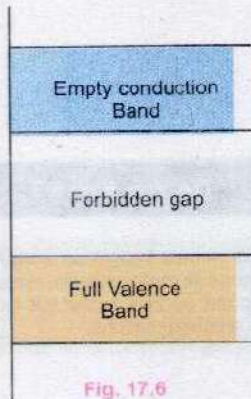


Fig. 17.6

**Insulators** Insulators are those materials in which valence electrons are bound very tightly to their atoms and are not free. In terms of energy bands, it means that an insulator, as shown in Fig. 17.6 has

- a) an empty conduction band (no free electrons)
- b) a full valence band
- c) a large energy gap (several eV) between them

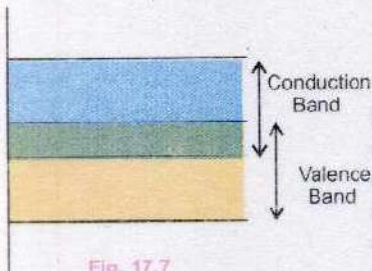


Fig. 17.7

**Conductors** Conductors are those which have plenty of free electrons for electrical conduction. In terms of energy bands, conductors are those materials in which valence and conduction bands largely overlap each other (Fig. 17.7). There is no physical distinction between the two bands which ensures the availability of a large number of free electrons.

**Semiconductors** In terms of energy bands, semiconductors are those materials which at room temperature have

- (i) partially filled conduction band
- (ii) partially filled valence band
- (iii) a very narrow forbidden energy gap (of the order of 1 eV) between the conduction and valence bands (Fig. 17.8).

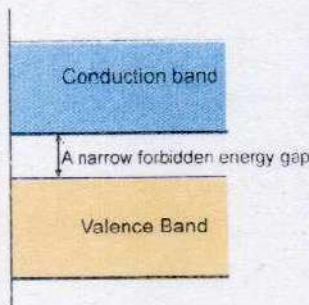


Fig. 17.8

At 0 K, there are no electrons in the conduction band and their valence band are completely filled. It means at 0 K, a piece of Ge or Si is a perfect insulator. However, with increase in temperature, some electrons possess sufficient energy to jump across the small energy gap from valence to conduction band. Thus at room temperature, Ge or Si crystal becomes a semiconductor.

### Intrinsic and Extrinsic Semi-conductor

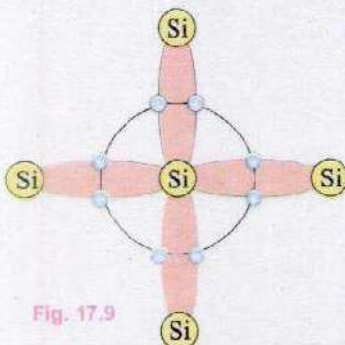


Fig. 17.9

A semi-conductor in its extremely pure form is known as intrinsic semi-conductor. The electrical behaviour of semiconductor is extremely sensitive to the purity of the material. It is substantially changed on introducing a small amount of impurity into the pure semi-conductor lattice. The process is called doping, in which a small number of atoms of some other suitable elements are added as impurity in the ratio of 1 to  $10^6$ . The doped semi-conducting materials are called extrinsic semi-conductors.

Pure element of silicon and germanium are intrinsic



semi-conductors. These semi-conductor elements have atoms with four valence electrons. In solid crystalline form, the atoms of these elements arrange themselves in such a pattern that each atom has four equidistant neighbours. Fig. 17.9 shows this pattern along with its valence electrons. Each atom with its four valence electrons, shares an electron from its neighbours. This effectively allocates eight electrons in the outermost shell of each atom which is a stable state. This sharing of electrons between two atoms creates covalent bonds. Due to these covalent bonds electrons are bound in their respective shells.

When a silicon crystal is doped with a pentavalent element, e.g., arsenic, antimony or phosphorous etc., four valence electrons of the impurity atom form covalent bond with the four neighbouring Si atoms, while the fifth valence electron provides a free electron in the crystal. Such a doped or extrinsic semi-conductor is called n-type semi-conductor. Fig. 17.10(a) illustrates silicon crystal lattice doped with a pentavalent impurity such as phosphorous. The phosphorous atom is called a donor atom because it readily donates a free electron, which is thermally excited into the conduction band.

On the other hand, when a silicon crystal is doped with a trivalent element, e.g., aluminium, boron, gallium or indium etc., three valence electrons of the impurity atom form covalent bond with the three neighbouring Si atoms, while the one missing electron in the covalent bond with the fourth neighbouring Si atom, is called a hole which in fact is vacancy where an electron can be accommodated. Such a semi-conductor is called p-type semi-conductor. Fig. 17.10 (b) illustrates silicon crystal lattice doped with aluminium. The aluminium atom is called an acceptor atom because it is easy for the aluminium ion core to accept a valence electron from a nearby silicon atom, thus creating a hole in the valence bond.

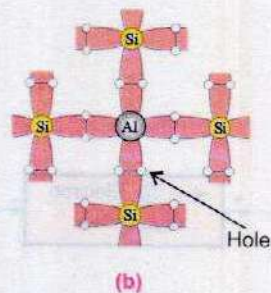
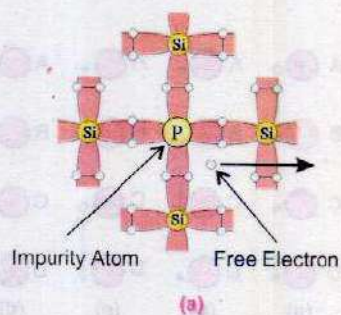


Fig. 17.10

### Electrical Conduction by Electrons and Holes in Semiconductors

Consider a semi-conductor crystal lattice, e.g., Ge or Si as shown in Fig. 17.11. The circles represent the positive ion cores of Si or Ge atoms, and the blue dots are valence electrons. These electrons are bound by covalent bond. However, at room temperature they have thermal kinetic motion which, in case of some electrons, is so vigorous that

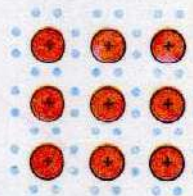


Fig. 17.11



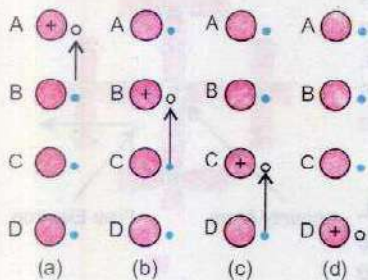


Fig. 17.12

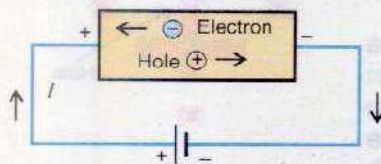


Fig. 17.13

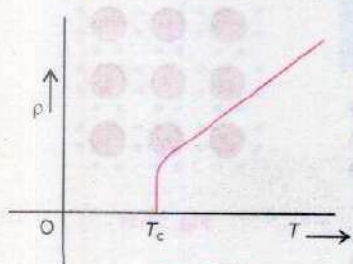


Fig. 17.14

the covalent bond is unable to keep them bound. In such cases the electrons break the covalent bond and get themselves free leaving a vacant seat for an electron, i.e., a hole. Thus whenever a covalent bond is broken, an electron-hole pair is created. Both the electrons and the holes move in the semi-conductor crystal lattice as explained below.

Consider a row of Si atoms in crystal lattice. Suppose a hole is present in the valence shell of atom A. As hole is a deficiency of electron, so the core of atom A would have a net positive charge (Fig. 17.12 a). This attracts an electron from a neighbouring atom say B. Thus the electron moves from B to A and the hole (+ve charge) shifts to B (Fig. 17.12 a,b). Now an electron is attracted from C to B and a hole is created at C (Fig. 17.12 b,c) and positive charge appears at C. This process is repeated between the atoms C and D with the result that the electron moves from D to C and the hole (+ve charge) appears at D (Fig. 17.12 c,d). Thus we notice that if a hole is present in any valence shell, it cannot stay there but it moves from one atom to other with the electron moving in opposite direction. Secondly we notice that the appearance of hole is accompanied by a positive charge. Thus a moving hole is equivalent to a moving positive charge.

In this example we have considered a special case in which the electron and the hole are moving in a straight line. Actually their motion is random because positively charged core of the atom can attract an electron from any of its neighbouring atoms.

Thus, in semi-conductors there are two kinds of charge carriers; a free electron ( $-e$ ) and a hole ( $+e$ ).

When a battery is connected to a semi-conductor, it establishes an electric field across it due to which a directed flow of electrons and holes takes place. The electrons drift towards the positive end, whereas the holes drift towards the negative end of the semi-conductor (Fig. 17.13). The current  $I$  flowing through the semi-conductor is carried by both electrons and holes. It may be noted that the electronic current and the hole current add together to give the current  $I$ .

## 17.4 SUPERCONDUCTORS

There are some materials whose resistivity becomes zero below a certain temperature  $T_c$  called critical temperature as shown in resistivity-temperature graph in Fig. 17.14. Below this temperature, such materials are called superconductors.



They offer no resistance to electric current and are, therefore, perfect conductors. Once the resistance of a material drops to zero, no energy is dissipated and the current, once established, continues to exist indefinitely without the source of an emf.

The first superconductor was discovered in 1911 by Kmaerlingh Ornes when it was observed that electrical resistance of mercury disappears suddenly as the temperature is reduced below 4.2 K. Some other metals such as aluminium ( $T_c = 1.18$  K), tin ( $T_c = 3.72$  K), and lead ( $T_c = 7.2$  K) also become superconductors at very low temperatures. In 1986 a new class of ceramic materials was discovered that becomes superconductor at temperatures as high as 125 K. Any superconductor with a critical temperature above 77 K, the boiling point of liquid nitrogen, is referred as a high temperature superconductor.

Recently a complex crystalline structure known as Yttrium barium copper oxide ( $YBa_2Cu_3O_7$ ) have been reported to become superconductor at 163 K or  $-110^\circ\text{C}$  by Prof. Yao Lian's Lee at Cambridge University. Perhaps one day even room temperature superconductor will be developed and that day will be a new revolution in electrical technologies. Superconductors have many technological applications such as in magnetic resonance imaging (MRI), magnetic levitation trains, powerful but small electric motors and faster computer chips.

## 17.5 MAGNETIC PROPERTIES OF SOLIDS

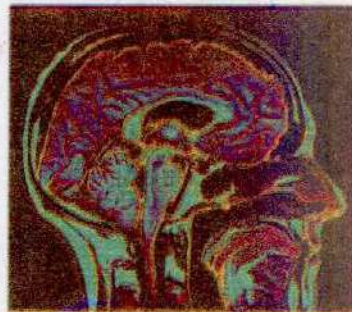
From the study of the magnetic fields produced by bar magnets and moving charges, i.e., currents, it is possible to trace the origin of the magnetic properties of the material. It is observed that the field of a long bar magnet is like the field produced by a long solenoid carrying current and the field of a short bar magnet resembles that of a single loop (Fig.17.15). This similarity between the fields produced by magnets and currents urges an enquiring mind to think that all magnetic effects may be due to circulating currents (i.e., moving charges); a view first held by Ampere. The idea was not considered very favourably in Ampere's time because the structure of atom was not known at that time. Taking into consideration, the internal structure of atom, discovered thereafter, the Ampere's view appears to be basically correct.

The magnetism produced by electrons within an atom can

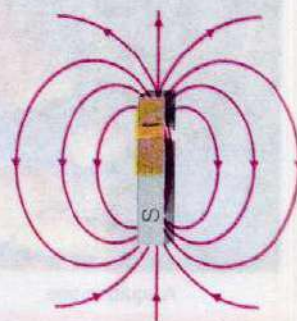
### Do You Know?

Super conductors are alloys that, at certain temperatures, conduct electricity with no resistance.

### For Your Information



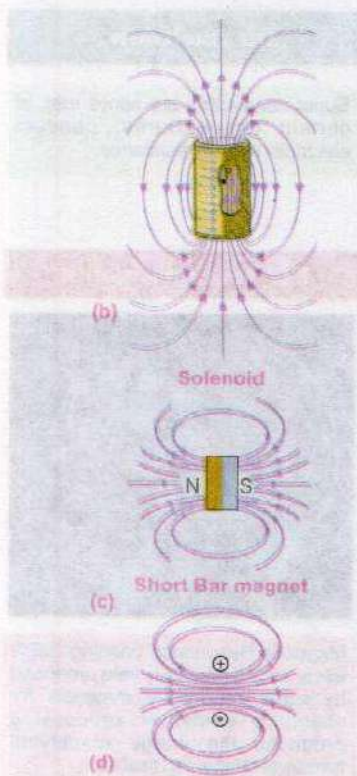
Magnetic Resonance imaging (MRI) uses strong magnetic field produced by super conducting materials for scanning computer processing produces the image identifying tumors and inflamed tissues.



(a)

Fig.17.15





Magnet field of a current loop

Fig. 17.15

### For Your Information



A squid in use

Squids ( or super-conducting quantum interference devices) are used to detect very weak magnetic field such as produced by the brain.

arise from two motions. First, each electron orbiting the nucleus behaves like an atomic sized loop of current that generates a small magnetic field; this situation is similar to the field created by the current loop in Fig.17.15 (d). Secondly each electron possesses a spin that also gives rise to a magnetic field. The net magnetic field created by the electrons within an atom is due to the combined field created by their orbital and spin motions. Since there are a number of electrons in an atom, their currents or spins may be so oriented or aligned as to cancel the magnetic effects mutually or strengthen the effects of each other. An atom in which there is a resultant magnetic field, behaves like a tiny magnet and is called a magnetic dipole. The magnetic fields of the atoms are responsible for the magnetic behaviour of the substance made up of these atoms. Magnetism is, therefore, due to the spin and orbital motion of the electrons surrounding the nucleus and is thus a property of all substances. It may be mentioned that the charged nucleus itself spins giving rise to a magnetic field. However, it is much weaker than that of the orbital electrons. Thus the source of magnetism of an atom is the electrons. Accepting this view of magnetism it is concluded that it is impossible to obtain an isolated north pole. The north-pole is merely one side of a current loop. The other side will always be present as a south pole and these cannot be separated. This is an experimental reality.

Two cases arise which have to be distinguished. In the first case, the orbits and the spin axes of the electrons in an atom are so oriented that their fields support each other and the atom behaves like a tiny magnet. Substances with such atoms are called paramagnetic substances. In second type of atoms there is no resultant field as the magnetic fields produced by both orbital and spin motions of the electrons might add upto zero. These are called diamagnetic substances, for example the atoms of water, copper, bismuth and antimony.

However, there are some solid substances e.g., Fe, Co, Ni, Chromium dioxide, and Alnico (an iron aluminium - nickel - cobalt alloy) in which the atoms co-operate with each other in such a way so as to exhibit a strong magnetic effect. They are called ferromagnetic substances. Ferromagnetic materials are of great interest for electrical engineers.

Recent studies of ferromagnetism have shown that there exists in ferromagnetic substance small regions called 'domains'. The domains are of macroscopic size of the order



of millimetres or less but large enough to contain  $10^{12}$  to  $10^{16}$  atoms. Within each domain the magnetic fields of all the spinning electrons are parallel to one another i.e., each domain is magnetized to saturation. Each domain behaves as a small magnet with its own north and south poles. In unmagnetised iron the domains are oriented in a disorderly fashion (Fig.17.16), so that the net magnetic effect of a sizeable specimen is zero. When the specimen is placed in an external magnetic field as that of a solenoid, the domains line up parallel to lines of external magnetic field and the entire specimen becomes saturated (Fig.17.17). The combination of a solenoid and a specimen of iron inside it thus makes a powerful magnet and is called an electromagnet.

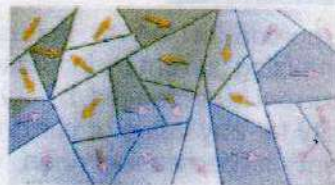


Fig. 17.16 Magnetic domains within an unmagnetized ferromagnet.

Iron is a soft magnetic material. Its domains are easily oriented on applying an external field and also readily return to random positions when the field is removed. This is desirable in an electromagnet and also in transformers. Domains in steel, on the other hand, are not so easily oriented to order. They require very strong external fields, but once oriented, retain the alignment. Thus steel makes a good permanent magnet and is known as hard magnetic material and another such material is a special alloy Alnico V.



Fig. 17.17

Finally, it must be mentioned that thermal vibrations tend to disturb the orderliness of the domains. Ferromagnetic materials preserve the orderliness at ordinary temperatures. When heated, they begin to lose their orderliness due to the increased thermal motion. This process begins to occur at a particular temperature (different for different materials) called Curie temperature. Above the Curie temperature iron is paramagnetic but not ferromagnetic. The Curie temperature for iron is about  $750^{\circ}\text{C}$ .

### Do You Know

Magnet made out of organic materials could be used in optical disks and components, in computers, mobile phones, TVs, motors generators and data storage devices. Circuits can make use of ceramic magnets that do not conduct electricity.

## Hysteresis Loop

To investigate a ferromagnetic material, a bar of that material such as iron is placed in an alternating current solenoid. When the alternating current is at its positive peak value, it fully magnetises the specimen in one direction and when the current is at its negative peak, it fully magnetises it in opposite direction. Thus as the alternating current changes from its positive peak value to its negative peak value and then back to its positive peak value, the specimen undergoes a complete cycle of magnetization. The flux density versus the magnetization current of the specimen for the various values of magnetizing current of the solenoid is plotted by a CRO (Fig. 17.18).

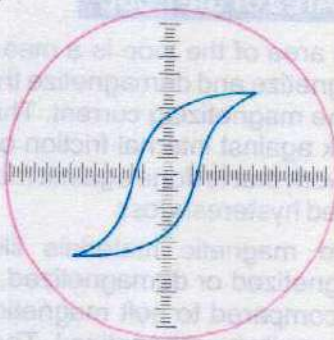


Fig. 17.18



Its main features are as follows:

### 1. Hysteresis

The portion of OA of the curve is obtained when the magnetizing current  $I$  is increased and AR is the portion when the current is decreased. It may be noted that the value of flux density for any value of current is always greater when the current is decreasing than when it is increasing, i.e., magnetism lags behind the magnetizing current. This phenomenon is known as hysteresis.

### 2. Saturation

The magnetic flux density increases from zero and reaches a maximum value. At this stage the material is said to be magnetically saturated.

### 3. Remanence or Retativity

When the current is reduced to zero, the material still remains strongly magnetized represented by point R on the curve. It is due to the tendency of domains to stay partly in line, once they have been aligned.

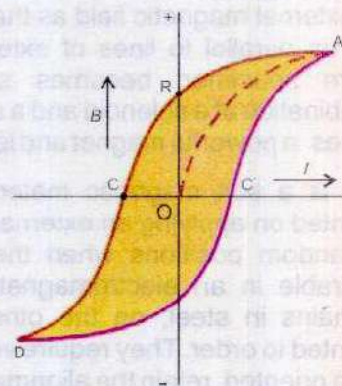
### 4. Coercivity

To demagnetize the material, the magnetizing current is reversed and increased to reduce the magnetization to zero. This is known as coercive current represented by C on the curve. The coercivity of steel (Fig. 17.19 a), is more than that of iron as more current is needed to demagnetize it. Once the material is magnetized, its magnetization curve never passes through the origin. Instead, it forms the closed loop ACDC'A, which is called hysteresis loop.

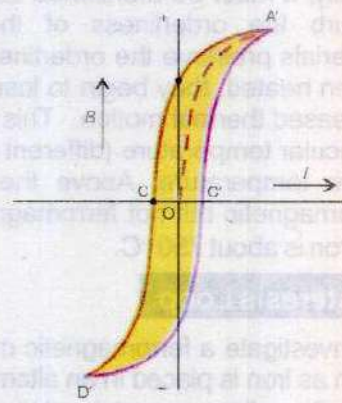
### 5. Area of the Loop

The area of the loop is a measure of the energy needed to magnetize and demagnetize the specimen during each cycle of the magnetizing current. This is the energy required to do work against internal friction of the domains. This work, like all work that is done against friction, is dissipated as heat. It is called hysteresis loss.

Hard magnetic materials like steel can not be easily magnetized or demagnetized, so they have large loop area as compared to soft magnetic material such as iron which can easily be magnetized. The energy dissipated per cycle, thus, for iron is less than for steel.



(a) Hysteresis loop of steel



(b) Hysteresis loop of soft iron

OR = Retentivity  
OC = Coercivity

Fig. 17.19



Suitability of magnetic materials for different purposes can be studied by taking the specimen through a complete cycle and drawing the hysteresis loop. A material with high retentivity and large coercive force would be most suitable to make a permanent magnet. The cores of electromagnets used for alternating currents where the specimen repeatedly undergoes magnetization and demagnetization should have narrow hysteresis curves of small area to minimize the waste of energy.



A bullet train is lifted above the rails due to magnetic effect, thus friction is reduced to minimum and speed can be enhanced up to 500kmh<sup>-1</sup>.

### SUMMARY

- Crystalline solids are those in which there is a regular arrangement of molecules. The neighbours of every molecule are arranged in a regular pattern that is constant through out the crystal. Thus, there is an ordered structure in crystalline solids.
- In amorphous solids there is no regular arrangement of molecules. These are more like liquids with the disordered structure frozen in.
- Polymers may be said to be more or less solid materials with a structure that is intermediate between order and disorder. These can be classified as partially or poorly crystalline solids.
- A crystalline solid consists of three dimensional pattern that repeats itself over and over again. This basic structure is called unit cell.
- The force applied on unit area to produce any change in the shape, volume or length of a body is called stress.
- When a long wire of length  $\ell$  with area of cross section  $A$  is being pulled by a force  $F$ , which results in an increase in length  $\Delta\ell$ , the stress is called tensile deformation.
- When a small cylinder is subjected to a force  $F$  along the inward drawn normal to its area of cross section  $A$  to reduce its length, the stress is called compressive stress and deformation produced by it is called compressive deformation.
- If a force  $F$  is applied tangentially to the surface of the opposite face of a cube to deform or twist it through an angle  $\theta$ , the stress is termed as shear stress.
- Strain is a measure of the deformation of a solid when stress is applied to it. In the case of deformation in one dimension, strain is defined as the fractional change in length per unit length. If strain is due to tensile stress, it is called tensile strain and if it is produced as a result of compressive stress, it is termed as compressive strain.
- The ratio of stress to strain is a constant for a given material, provided the external applied force is not too great. This is called modulus of elasticity.
- The strain energy can be obtained by the area of the force-extension graph.
- The electrical behaviour of semi-conductor is substantially changed on introducing



a small amount of impurity into the pure semi-conductor lattice. The process is called doping in which a small number of atoms of some other suitable elements are added as impurity. The doped semi-conducting materials are called extrinsic.

- When a silicon crystal is doped with a pentavalent element, four valence electrons of the impurity atom form covalent bond with the neighbouring Si atoms, while the fifth valence electron provides a free electron in the crystal. Such a doped or extrinsic semi-conductor is called n-type semi-conductor.
- There are some materials whose resistivity becomes zero below a certain temperature  $T_c$ , called critical temperature. Below this temperature, such materials are called superconductors.
- Substances in which the orbits and the spin axes of the electrons in an atom are so oriented that their magnetic fields support each other and the atom behaves like a tiny magnet are called paramagnetic substances.
- The substances in which magnetic fields produced by orbital and spin molecules of the electrons add up to zero are called diamagnetic substances.
- Substances in which the atoms co-operate with each other in such a way so as to exhibit a strong magnetic effect are called ferromagnetic.

### QUESTIONS

- 17.1 Distinguish between crystalline, amorphous and polymeric solids.
- 17.2 Define stress and strain. What are their SI units? Differentiate between tensile, compressive and shear modes of stress and strain.
- 17.3 Define modulus of elasticity. Show that the units of modulus of elasticity and stress are the same. Also discuss its three kinds.
- 17.4 Draw a stress-strain curve for a ductile material, and then define the terms: Elastic limit, Yield point and Ultimate tensile stress.
- 17.5 What is meant by strain energy? How can it be determined from the force-extension graph?
- 17.6 Describe the formation of energy bands in solids. Explain the difference amongst electrical behaviour of conductors, insulators and semi-conductors in terms of energy band theory.
- 17.7 Distinguish between intrinsic and extrinsic semi-conductors. How would you obtain n-type and p-type material from pure silicon? Illustrate it by schematic diagram.
- 17.8 Discuss the mechanism of electrical conduction by holes and electrons in a pure semi-conductor element.
- 17.9 Write a note on superconductors.
- 17.10 What is meant by para, dia and ferromagnetic substances? Give examples for each.
- 17.11 What is meant by hysteresis loss? How is it used in the construction of a transformer?



## PROBLEMS

- 17.1** A 1.25 cm diameter cylinder is subjected to a load of 2500 kg. Calculate the stress on the bar in mega pascals. (Ans: 200 MPa)
- 17.2** A 1.0 m long copper wire is subjected to stretching force and its length increases by 20 cm. Calculate the tensile strain and the percent elongation which the wire undergoes. (Ans: 0.20, 20%)
- 17.3** A wire 2.5 m long and cross-section area  $10^{-5} \text{ m}^2$  is stretched 1.5 mm by a force of 100 N in the elastic region. Calculate (i) the strain (ii) Young's modulus (iii) the energy stored in the wire. (Ans:  $6.02 \times 10^{-4}$ ,  $1.66 \times 10^{10} \text{ Pa}$ ,  $7.5 \times 10^{-2} \text{ J}$ )
- 17.4** What stress would cause a wire to increase in length by 0.01% if the Young's modulus of the wire is  $12 \times 10^{10} \text{ Pa}$ . What force would produce this stress if the diameter of the wire is 0.56 mm? (Ans:  $1.2 \times 10^9 \text{ Pa}$ , 2.96 N)
- 17.5** The length of a steel wire is 1.0 m and its cross-sectional area is  $0.03 \times 10^{-4} \text{ m}^2$ . Calculate the work done in stretching the wire when a force of 100 N is applied within the elastic region. Young's modulus of steel is  $3.0 \times 10^{11} \text{ Nm}^{-2}$ . (Ans:  $5.6 \times 10^{-3} \text{ J}$ )
- 17.6** A cylindrical copper wire and a cylindrical steel wire each of length 1.5 m and diameter 2.0 mm are joined at one end to form a composite wire 3.0 m long. The wire is loaded until its length becomes 3.003 m. Calculate the strain in copper and steel wires and the force applied to the wire. (Young's modulus of copper is  $1.2 \times 10^{11} \text{ Pa}$  and for steel is  $2.0 \times 10^{11} \text{ Pa}$ ). (Ans:  $1.25 \times 10^{-3}$ ,  $7.5 \times 10^{-4}$ , 477 N)



# Chapter 18

## ELECTRONICS

### Learning Objectives

At the end of this chapter the students will be able to:

1. Describe forward and reverse biasing of a p-n junction.
2. Understand half and full wave rectification.
3. Know the uses of light emitting diode, photo diode and photo voltaic cell.
4. Describe the operation of transistor.
5. Know current equation and solve related problems.
6. Understand the use of transistors as an amplifier and a switch.
7. Understand operational amplifier and its characteristics.
8. Know the applications of an operational amplifier as inverting and non-inverting amplifier using virtual ground concept.
9. Understand the use of an operational amplifier as a comparator e.g., night switch.
10. Understand the function of each of the following logic gates: AND, NOT, OR and NAND gates and represent their functions by means of truth tables (limited to a maximum of two inputs).
11. Describe how to combine different gates to form XOR and XNOR gates.
12. Understand combinations of logic gates to perform control functions.

**T**he huge advances in electronics over the recent past are due to discovery and use of semi-conductors. Silicon is one of the most commonly used semi-conductors, and is the basic material from which highly sophisticated integrated circuits known as 'chips' are made. The use of chips in analogue as well as in digital electronics is described in the form of the black boxes. This chapter is based on the preliminary concepts introduced in the secondary school physics course.

### 18.1 BRIEF REVIEW OF p-n JUNCTION AND ITS CHARACTERISTICS

A p-n junction is formed when a crystal of germanium or silicon is grown in such a way that its one half is doped with a trivalent impurity and the other half with a pentavalent impurity. One of the most important building blocks of electronic devices is the p-n junction. Its n-region contains free electrons as majority charge carriers and p-region contains holes as majority charge carriers. Just after the formation of the junction, the free electrons in the n-region, because of their random motion, diffuse into the p-region. As a result of this diffusion, a region is formed around the junction in which charge carriers are not present. This region is known as depletion region (Fig. 18.1 a). In this figure, blue dots represent the free electrons and the small circles show the holes whereas the circles with + and - signs show the positive and negative ions which constitute the depletion region. Due to charge on



these ions a potential difference develops across the depletion region (Fig.18.1 b). Its value is 0.7 V in case of silicon and 0.3 V in case of germanium. This potential difference, called potential barrier, stops further diffusion of electrons into the p-region.

### Forward Biased p-n Junction

When an external potential difference is applied across a p-n junction such that p-side is positive and n-side is negative, then this external potential difference supplies energy to free electrons in the n-region and to holes in p-region. When this energy is sufficient to overcome the potential barrier, a current of the order of a few miliamperes begins to flow across the p-n junction. In this state the p-n junction is said to be forward biased (Fig. 18.2 a). The variation of current through the junction with the bias voltage can be studied by the circuit shown in Fig. 18.2 (b). The value of current for different values of bias voltage is noted and a current-bias voltage graph is plotted. Fig. 18.3 shows the graph for a typical low power silicon diode.

As shown in Fig.18.3, if forward bias voltage is increased by  $\Delta V_f$ , the current increases by  $\Delta I_f$ . The ratio  $\Delta V_f/\Delta I_f$  is known as forward resistance of the p-n junction, i.e.,

$$r_f = \frac{\Delta V_f}{\Delta I_f} \dots\dots\dots (18.1)$$

It is the resistance offered by the p-n junction when it is conducting. The value of  $r_f$  is only a few ohms.

### Reverse Biased p-n Junction

When the external source of voltage is applied across a p-n junction such that its positive terminal is connected to n-region and its negative terminal to p-region, the p-n junction is said to be reverse biased (Fig. 18.4). In this situation no current flows due to the majority charge carries. However a very small current, of the order of few microamperes flows across the junction due to flow of minority charge carriers (Fig.18.4). It is known as reverse current or leakage current. The variation of reverse current with the applied bias voltage can be studied by the circuit shown in Fig.18.5. Fig.18.6 shows the reverse characteristic for the p-n junction. It can be seen that as the reverse voltage is increased from 0, the reverse current quickly rises to its saturation value  $I_o$ . As the reverse voltage is further increased, the reverse current

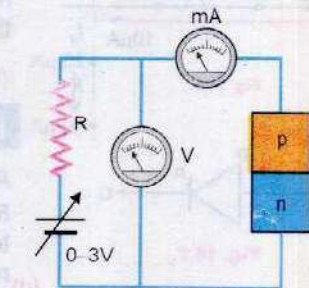
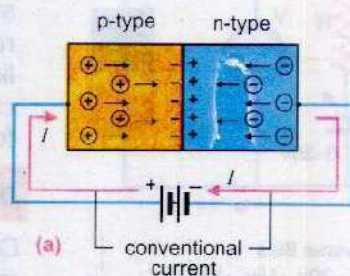
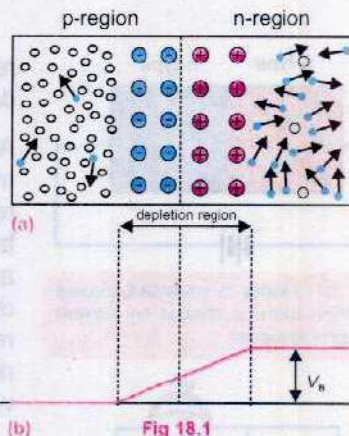
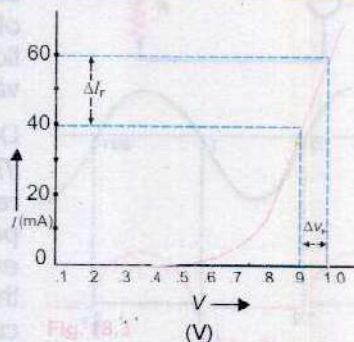
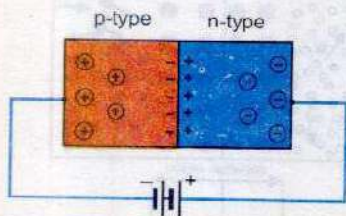


Fig 18.2 There is an appreciable current through the diode when the diode is forward biased.





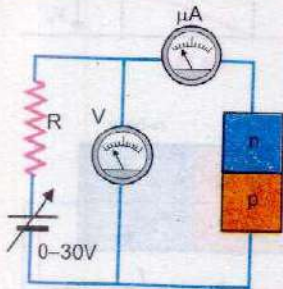


**Fig. 18.4:** Under a reversed biased condition there is almost no current through the diode.

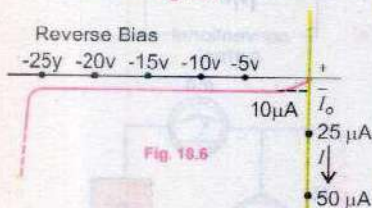
remains almost constant. Here the resistance offered by the diode is very high - of the order of several mega ohms.

As the reverse voltage is increased, the kinetic energy of the minority charge carriers with which they cross the depletion region also increases till it is sufficient to break a covalent bond. As the covalent bond breaks, more electron-hole pairs are created. Thus, minority charge carriers begin to multiply due to which the reverse current begin to increase till a point is reached when the junction breaks down and reverse current rises sharply (Fig. 18.6). After breakdown the reverse current will rise to very high value which will damage the junction.

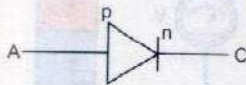
P-n junction is also known as a semi-conductor diode whose symbolic representation is given in Fig. 18.7. The arrow head represents the p - region and is known as anode. The vertical line represents the n-region and is known as cathode. The current flows in the direction of arrow when the diode is forward biased.



**Fig. 18.5**



**Fig. 18.6**



**Fig. 18.7**

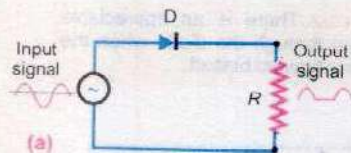
## 18.2 RECTIFICATION

Conversion of alternating current into direct current is called rectification. Semi-conductor diodes are extensively used for this purpose. There are two very common types of rectification.

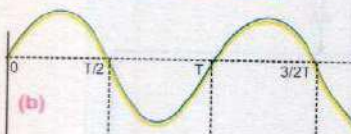
- (i) Half-wave rectification and
- (ii) Full-wave rectification

### Half-Wave Rectification

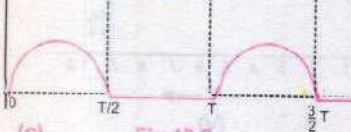
A half-wave rectification is shown in Fig. 18.8 where an alternating voltage of period  $T$  called input voltage is applied to a diode  $D$  which is connected in series with a load resistance  $R$ . In this method only one half of alternating current cycle is converted into direct current.



(a)



(b)



(c)

**Fig. 18.8**

During the positive half cycle of the input alternating voltage i.e., during the interval  $0 \rightarrow T/2$ , the diode  $D$  is forward biased, so it offers a very low resistance and current flows through  $R$ . The flow of current through  $R$  causes a potential drop across it which varies in accordance with the alternating input (Fig. 18.8 c).

During the negative half cycle i.e., during the period  $T/2 \rightarrow T$ , the diode is reverse biased. Now it offers a very high resistance, so practically no current flows through  $R$  and potential drop across it is almost zero (Fig. 18.8 c). The same events repeat during the next cycle and so on. The current through  $R$  flows in only one direction which means it is a direct current. However, this current flows in pulses (Fig. 18.8 c). The



voltage which appears across load resistance  $R$  is known as output voltage.

### Full-Wave Rectification

We have seen that in a half-wave rectification, only one half of the alternating input voltage is used to send a unidirectional current through a resistance. However both halves of the input voltage cycle can be utilized using full-wave rectification. Its circuit consists of four diodes connected in a bridge type arrangement (Fig. 18.9). To understand the operation of the circuit, recall that a diode conducts only when it is forward biased. During the positive half cycle, i.e., during the time  $0 \rightarrow T/2$ , the terminal A of the bridge is positive with respect to its other terminal B. Now the diodes  $D_1$  and  $D_3$  become forward biased and conduct. A current flows through the circuit in the direction shown by arrows in Fig. 18.9 (a). During the negative half cycle, i.e., during the time interval  $T/2 \rightarrow T$ , terminal A is negative and B is positive. Now the diodes  $D_4$  and  $D_2$  conduct and current flows through the circuit in the path shown by arrows in Fig. 18.9 (b). By comparing Figs. 18.9 (a) and 18.9 (b), it can be seen that direction of current flow through the load resistance  $R$  is the same in both the halves of the cycle. Thus both halves of the alternating input voltage send a unidirectional current through  $R$ . The input and output voltages are shown in Fig. 18.10. However the output voltage is not smooth but pulsating. It can be made smooth by using a circuit known as filter.

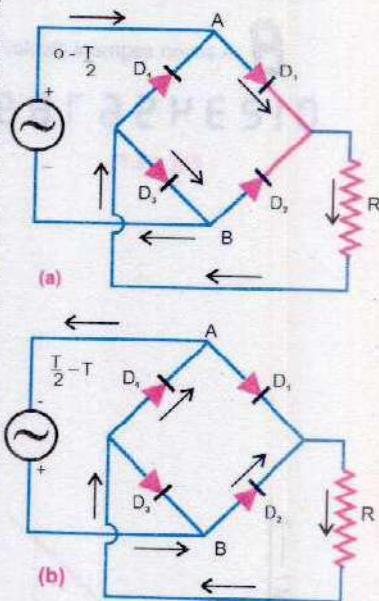


Fig. 18.9

### 18.3 SPECIALLY DESIGNED p-n JUNCTIONS

In addition to the use of semi-conductor diode as rectifier, many types of p-n junctions have been developed for special purposes. Three most commonly used such diodes are

- (i) Light emitting diode
- (ii) Photo diode
- (iii) Photo voltaic cell

#### Light Emitting Diode

Light emitting diodes (LED) are made from special semi-conductors such as gallium arsenide and gallium arsenide phosphide in which the potential barrier between p and n sides is such that when an electron combines with a hole during forward bias conduction, a photon of visible light is emitted. These diodes are commonly used as small light

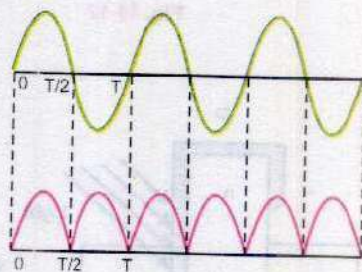


Fig. 18.10



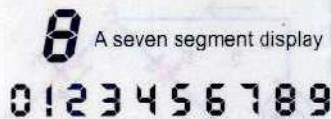


Fig. 18.11

sources. A specially formed array of seven LED's is used for displaying digits etc., in electronic appliances (Fig. 18.11).

### Photo Diode

Photo diode is used for the detection of light. It is operated in the reverse biased condition (Fig. 18.12 a). A photo diode symbol is shown in Fig. 18.12 (b). When no light is incident

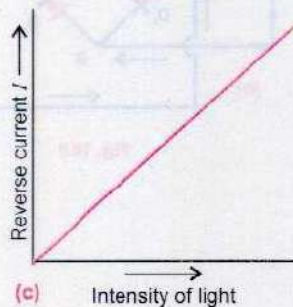


Fig. 18.12

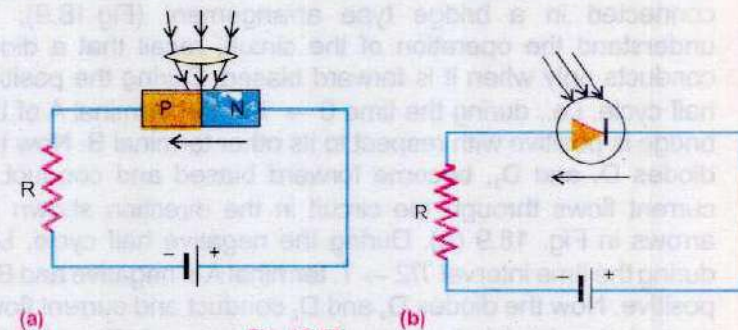


Fig. 18.12

on the junction, the reverse current  $I$  is almost negligible but when its p-n junction is exposed to light, the reverse current increases with the intensity of light (Fig.18.12 c).

A photo diode can turn its current ON and OFF in nano-seconds. Hence it is one of the fastest photo detection devices. Applications of photo diode include

- i. Detection of both visible and invisible radiations
- ii. Automatic switching
- iii. Logic circuits
- iv. Optical communication equipment etc.

### Photo-Voltaic Cell

It consists of a thick n-type region covered by a thin p-type layer. When such a p-n junction having no external bias (Fig.18.13), is exposed to light, absorbed photons generate electron-hole pairs. It results into an increase percentage of minority charge carriers in both the p and n-regions and when they diffuse close to the junction, the electric field due to junction potential barrier sweeps them across the junction. It causes a current flow through the external circuit R. The current is proportional to intensity of light.

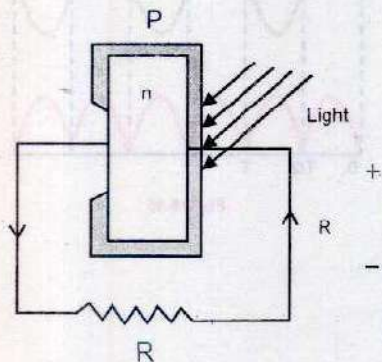


Fig. 18.13



## 18.4 TRANSISTORS

A transistor consists of a single crystal of germanium or silicon which is grown in such a way that it has three regions (Figs. 18.14 & 18.15).

In Fig. 18.14 the central region is p type which is sandwiched between two n type regions. It is known as n-p-n transistor. In Fig. 18.15, the n type central region is sandwiched between two p type regions. It forms a p-n-p transistor. The central region is known as base and the other two regions are called emitter and collector. Usually the base is very thin, of the order of  $10^{-6}$  m. The emitter and collector have greater concentration of impurity. The collector is comparatively larger than the emitter. The emitter has greater concentration of impurity as compared to the collector.

It can be seen in Figs. 18.14 and 18.15 that a transistor is a combination of two back to back p-n junctions: emitter-base junction and collector-base junction.

For normal operation of the transistor, batteries  $V_{BB}$  and  $V_{CC}$  are connected in such a way that its emitter-base junction is forward biased and its collector base junction is reverse biased.  $V_{CC}$  is of much higher value than  $V_{BB}$ . Fig. 18.16 shows the biasing arrangement for n-p-n transistor when the transistor has been represented by its symbolic form. Fig. 18.17 shows the same for a p-n-p transistor.

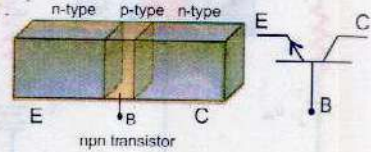


Fig. 18.14

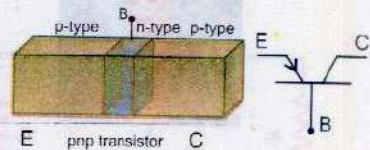


Fig. 18.15

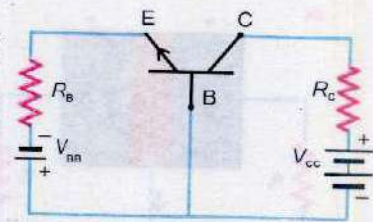


Fig. 18.16

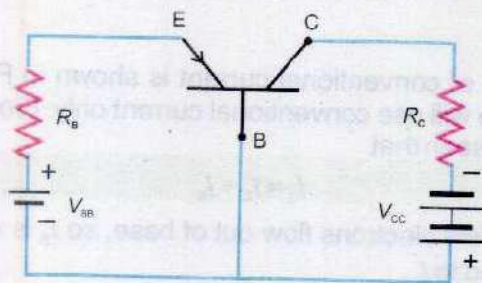


Fig. 18.17

It may be noted that polarities of the biasing batteries  $V_{BB}$  and  $V_{CC}$  are opposite in the two types of the transistors. In actual practice, it is the n-p-n transistor that is generally used. So we will discuss n-p-n transistors only.



## Current Flow in a n-p-n Transistor

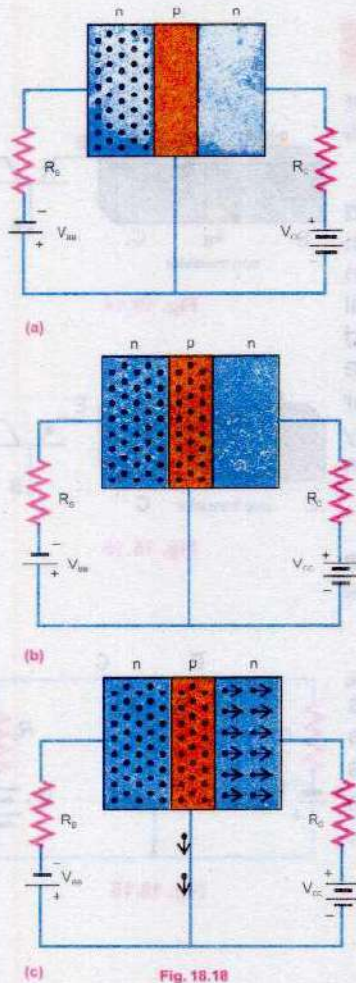


Fig. 18.18

Fig. 18.18 (a) shows a n-p-n transistor at the instant when the biasing voltage is applied. Electrons in the emitter, shown by black dots, have not yet entered the base region. After the application of the biasing voltage, emitter base junction is forward biased, so emitter injects a large number of electrons in base region (Fig.18.18 b). These free electrons in the base can flow in either of two directions. They can either flow out of the base to the positive terminal of  $V_{BB}$  or they can be attracted towards the collector because of battery  $V_{CC}$ . Since the base is extremely thin, very few electrons manage to recombine with holes and escape out of the base. Almost all of the free electrons injected from the emitter into the base are attracted by the collector due to its large positive potential  $V_{CC}$  (Fig. 18.18 c). Thus, in a normally biased transistor due to above mentioned flow of electrons, we can say, that an electronic current  $I_E$ , flows from the emitter into the base. A very small part of it, current  $I_B$ , flows out of the base, the rest of it  $I_C$  flows out of the collector (Fig. 18.19)

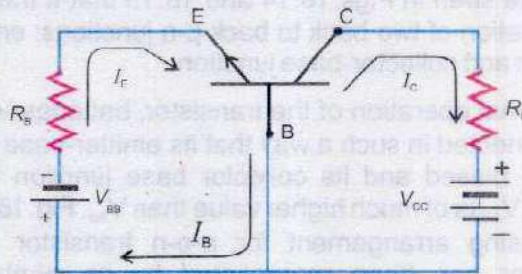


Fig. 18.19

The flow of conventional current is shown in Fig. 18.20. In future we will use conventional current only. From the figure it can be seen that

$$I_E = I_C + I_B \quad \dots\dots\dots (18.2)$$

As very few electrons flow out of base, so  $I_B$  is very small as compared to  $I_C$ .

It is also found that for a given transistor the ratio of collector current  $I_C$  to base current  $I_B$  is nearly constant i.e.,

$$\beta = \frac{I_C}{I_B} \quad \dots\dots\dots (18.3)$$

The ratio  $\beta$  is called current gain of transistor. Its value is quite large - of the order of hundreds. Eqs.18.2 and 18.3 are

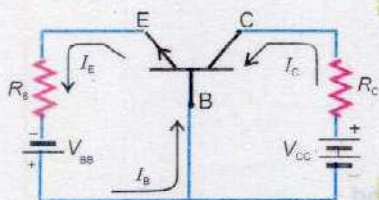


Fig. 18.20



fundamental equations of all transistors.

**Example 18.1:** In a certain circuit, the transistor has a collector current of 10 mA and a base current of 40  $\mu$ A. What is the current gain of the transistor?

**Solution:**

$$\beta = \frac{I_C}{I_B} = \frac{10 \times 10^{-3} \text{ A}}{40 \times 10^{-6} \text{ A}} = 250$$

## 18.5 TRANSISTOR AS AN AMPLIFIER

In majority of electronic circuits, transistors are basically used as amplifiers. An amplifier is thus the building block of every complex electronic circuit. It is for this reason that study of transistor amplifier is important.

The circuit in Fig. 18.21 is a transistor voltage amplifier. The battery  $V_{BB}$  forward biases the base-emitter junction and  $V_{CC}$  reverse biases the collector-base junction.  $V_{BE}$  and  $V_{CE}$  are the input and output voltages respectively. The base current is  $I_B = v_{BE}/r_{ie}$  where  $r_{ie}$  is base emitter resistance of the transistor. The transistor amplifies it  $\beta$  times. So

$$I_C = \beta I_B = \beta \cdot V_{BE} / r_{ie}$$

The output voltage  $V_o = V_{CE}$  is determined by applying KVL equation in the output loop which gives

$$V_{CC} = I_C R_C + V_{CE} \quad \text{or} \quad V_{CE} = V_{CC} - I_C R_C$$

Substituting the value of  $I_C$  and replacing  $V_{CE}$  by  $V_o$

$$V_o = V_{CC} - \beta V_{BE} R_C / r_{ie} \quad \dots\dots\dots 18.4(a)$$

When small signal voltage  $\Delta V_{in}$  is applied at the input terminal B, the input voltage changes from  $V_{BE}$  to  $V_{BE} + \Delta V_{in}$ . This causes a little change in base current from  $I_B$  to  $(I_B + \Delta I_B)$  due to which the collector current changes from  $I_C$  to  $(I_C + \Delta I_C)$ . As the collector current changes, the voltage drop across  $R_C$  i.e.  $(I_C R_C)$  also changes due to which the output voltage  $V_o$  changes by  $\Delta V_o$ . Substituting the changed values in Eq. 18.4(a)

$$V_o + \Delta V_o = V_{CC} - \beta (V_{BE} + \Delta V_{in}) R_C / r_{ie} \quad \dots\dots\dots 18.4(b)$$

Subtracting Eq. 18.4(a) from Eq. 18.4(b)

$$\Delta V_o = -\beta \Delta V_{in} R_C / r_{ie}$$

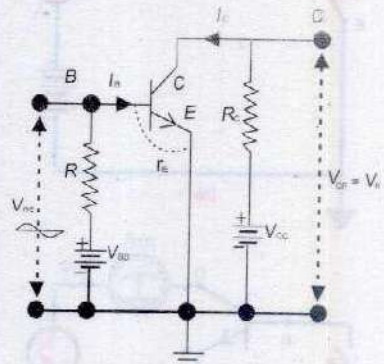
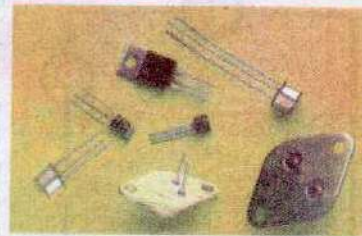


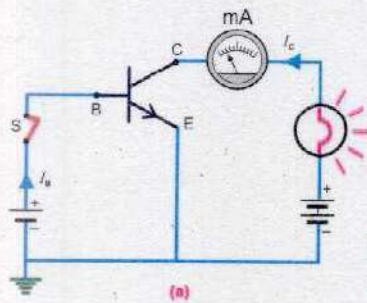
Fig. 18.21

### For Your Information



Various shapes of transistors.

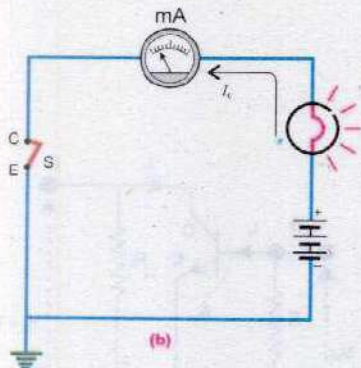




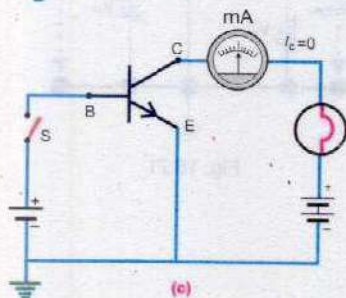
Therefore the gain of the amplifier  $A = \Delta V_o / \Delta V_i = \beta R_c / r_{ie}$ . The value of the factor  $\beta R_c / r_{ie}$  is of the order of hundreds, so the input voltage is amplified. The negative sign shows that there is a phase shift of  $180^\circ$  between the input and the output signals.

## 18.6 TRANSISTOR AS A SWITCH

Fig. 18.22 (a) shows the circuit in which a transistor is used as a switch. The collectors C and emitter E behave as the terminals of the switch. The circuit in which the current is to be turned OFF and ON, is connected across these terminals. The base B and emitter E act as control terminals which decide the state of the switch.



In order to turn on the switch, a potential  $V_B$  is applied between control terminals B-E (Fig. 18.22 a). This injects a large current  $I_B$  into the base circuit due to which a very heavy current  $I_C$  begins to flow in the CE circuit. This large value of collector current is possible only when the resistance between C and E drops down to such a small value that the potential drop across CE is nearly 0.1 volt. In Fig. 18.22 (a) emitter is at ground, so we can assume that collector is also at ground and collector emitter circuit of Fig. 18.22 (a) can be drawn as shown in Fig. 18.22 (b). CE switch is closed and the bulb glows due to flow of large collector current. To turn the switch OFF the base current  $I_B$  is set zero by opening the base circuit (Fig. 18.22 c). As  $I_C = \beta I_B$ , so  $I_C$  becomes zero and C-E circuit becomes open (Fig. 18.22 d). Now the resistance between C and E becomes nearly infinity which opens the CE switch.



An electronic computer is basically a vast arrangement of electronic switches which are made from transistors.

## 18.7 OPERATIONAL AMPLIFIER

As stated earlier, amplifier is an important electronic circuit that is used in almost every electronic instrument. So instead of making amplifier circuit by discrete components, the whole amplifier is integrated on a small silicon chip and enclosed in a capsule. Pins connected with working terminals such as input, output and power supply project outside the capsule (Fig. 18.23 a). The enclosed circuit of the amplifier is used by making requisite connections with these pins. Such an

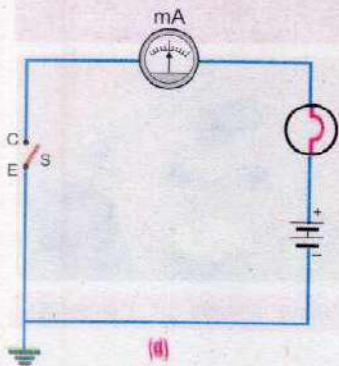


Fig. 18.22



integrated amplifier is known as operational amplifier (op-amp), as it is some times used to perform mathematical operations electronically.

The op-amp is usually represented by its symbol shown in Fig.18.23 (b). It has two input terminals. One is known as inverting input (-) and the other non-inverting input (+). A signal that is applied at the inverting (-) input, appears after amplification, at the output terminal with a phase shift of 180° (Fig. 18.24 a). It can be seen that the signal is inverted as it appears at the output. This is why this terminal is known as inverting. If the signal is applied at non-inverting input (+), it is amplified at the output without any change of phase (Fig. 18.24 b).

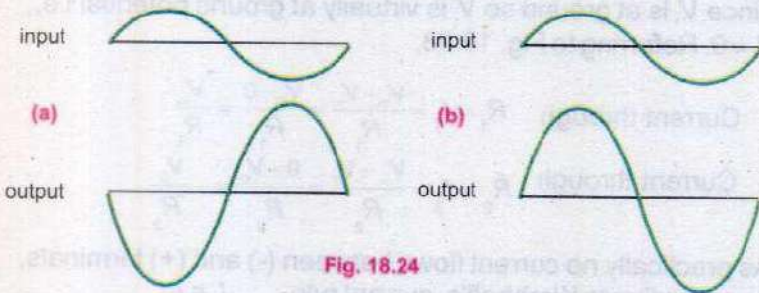


Fig. 18.24

### Characteristics of op-amp

An op-amp has a large number of characteristic parameters. We will discuss only three of them.

#### (i) Input Resistance

It is the resistance between the (+) and (-) inputs of the amplifier (Fig. 18.25). Its value is very high -- of the order of several mega ohms. Due to high value of the input resistance  $R_{in}$ , practically no current flows between the two input terminals. It is a very important feature of op-amps.

#### (ii) Output Resistance

It is the resistance between the output terminal and ground (Fig. 18.26). Its value is only a few ohms.

#### (iii) Open Loop Gain

It is the ratio of output voltage  $V_o$  to the voltage difference between non-inverting and inverting inputs when there is no external connection between the output and the inputs (Fig.18.27) i.e.,

$$A_{OL} = \frac{V_o}{V_+ - V_-} = \frac{V_o}{V_i} \dots\dots\dots (18.5)$$

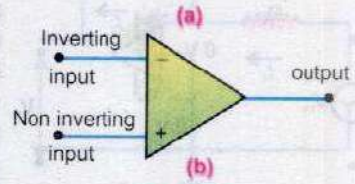


Fig. 18.23

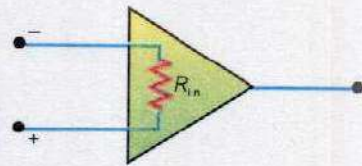


Fig. 18.25

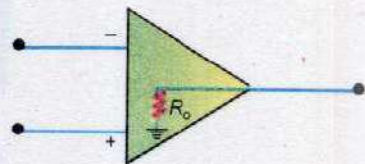


Fig. 18.26

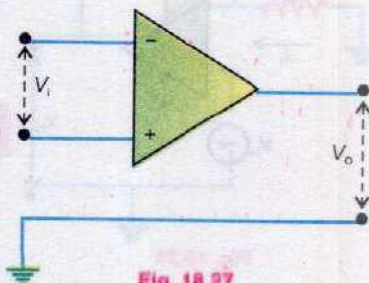


Fig. 18.27



The open loop gain of the amplifier is very high. It is of the order of  $10^5$ .

### 18.8 OP-AMP AS INVERTING AMPLIFIER

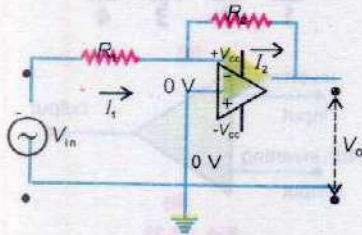


Fig. 18.28

Fig. 18.28 shows the circuit of an op-amp when used as an inverting amplifier. The input signal  $V_{in}$  which is to be amplified, is applied at inverting terminal (-) through a resistance  $R_1$ .  $V_o$  is its output. The non-inverting terminal (+) is grounded, i.e., its potential is zero. We know that  $A_{OL}$  is very high, of the order of  $10^5$ . As  $V_o$  may have any value between  $+V_{CC}$  (+12V) and  $-V_{CC}$  (-12V) so according to Eq.18.5, for finite ( $\pm 12V$ ) value of  $V_o$ ,  $V_+ - V_- \approx 0$  or  $V_+ \approx V_-$ . Since  $V_+$  is at ground so  $V_-$  is virtually at ground potential i.e.,  $V_- \approx 0$ . Referring to Fig. 18.28,

$$\text{Current through } R_1 = I_1 = \frac{V_{in} - V_-}{R_1} = \frac{V_{in} - 0}{R_1} = \frac{V_{in}}{R_1}$$

$$\text{Current through } R_2 = I_2 = \frac{V_- - V_o}{R_2} = \frac{0 - V_o}{R_2} = -\frac{V_o}{R_2}$$

As practically no current flows between (-) and (+) terminals, so according to Kirchoff's current rule  $I_1 = I_2$

$$\text{or } \frac{V_{in}}{R_1} = -\frac{V_o}{R_2} \quad \text{or } \frac{V_o}{V_{in}} = -\frac{R_2}{R_1}$$

As  $V_o/V_{in}$  is defined as gain  $G$  of the inverting amplifier, so

$$G = -\frac{R_2}{R_1} \quad \dots \dots \dots (18.6)$$

The negative sign indicates that the output signal is  $180^\circ$  out of phase with respect to input signal. It is interesting to note that the closed loop gain depends upon the two externally connected resistances  $R_1$  and  $R_2$ . The gain is independent of what is happening inside the amplifier.

If  $R_1 = 10 \text{ k}\Omega$  and  $R_2 = 100 \text{ k}\Omega$ , the gain of the amplifier is

$$G = \frac{V_o}{V_{in}} = -\frac{R_2}{R_1} = -\frac{100 \text{ k}\Omega}{10 \text{ k}\Omega} = -10$$

### 18.9 OP-AMP AS NON-INVERTING AMPLIFIER

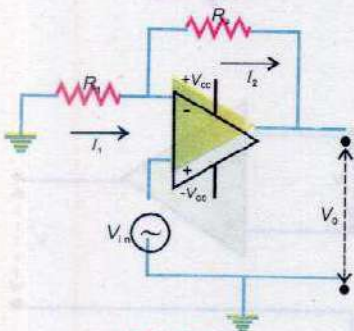


Fig. 18.29

The circuit diagram of op-amp as non-inverting amplified is shown in Fig. 18.29. In this case the input signal  $V_{in}$  is applied at the non-inverting terminal (+). As explained earlier, due to high open loop gain of amplifier, the inverting (-) and non



inverting (+) inputs are virtually at the same potential. That is,

$$V_- \approx V_+ = V_{in}$$

Also, from Fig. 18.29,

$$\text{Current through } R_1 = I_1 = \frac{0 - V_-}{R_1} = \frac{0 - V_{in}}{R_1} = \frac{-V_{in}}{R_1}$$

$$\text{Current through } R_2 = I_2 = \frac{V_- - V_o}{R_2} = \frac{V_{in} - V_o}{R_2}$$

As practically no current flows between (-) and (+) terminals, so by Kirchoff's current rule  $I_1 = I_2$

Hence 
$$\frac{-V_{in}}{R_1} = \frac{V_{in} - V_o}{R_2}$$

or 
$$V_{in} \left( \frac{1}{R_1} + \frac{1}{R_2} \right) = \frac{V_o}{R_2}$$

or 
$$\text{Gain} = \frac{V_o}{V_{in}} = 1 + \frac{R_2}{R_1} \dots\dots\dots (18.7)$$

Again the gain of the amplifier is independent of the internal structure of the op-amp. It just depends upon the two externally connected resistances  $R_1$  and  $R_2$ . The positive sign of gain indicates that the input and out put signals are in phase.

**Example 18.2:** Find the gain of the circuit as shown in Fig. 18.30.

**Solution:**

As the input signal  $V_{in}$  is connected to non-inverting input (+), so the op-amp acts as a non-inverting amplifier. Comparing it with the circuit of non-inverting amplifier as shown in Fig. 18.29, we have

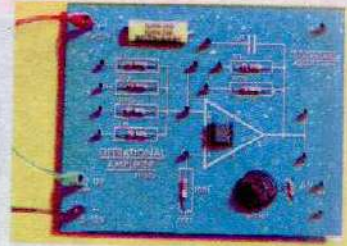
$$R_1 = \text{infinity} \quad \text{and} \quad R_2 = 0$$

$$\therefore \text{Gain} = 1 + \frac{R_2}{R_1} = 1$$

## 18.10 OP-AMP AS A COMPARATOR

Op-amp usually requires two power supplies of equal voltage but of opposite polarity. Most op-amp operate with  $V_{cc} = \pm 12V$  supply (Fig. 18.31).

### For Your Information



An op amplifier – The circuits in the black box.

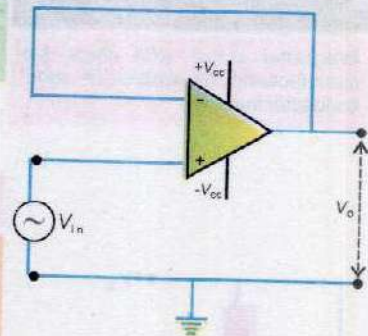


Fig. 18.30

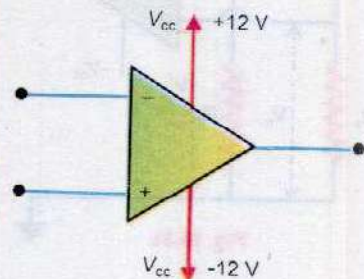


Fig. 18.31

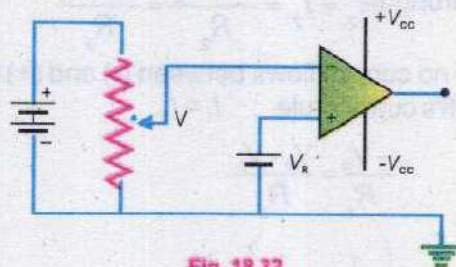


**For Your Information**



Integrated circuit (IC) chips are manufactured on wafers of semiconductor material.

As the open loop gain of the op-amp is very high ( $10^5$ ), even a very small potential difference between the inverting and non-inverting inputs is amplified to such a large extent that the amplifier gets saturated, i.e., its output either becomes equal to  $+V_{CC}$  or  $-V_{CC}$ . This feature of op-amp is used to compare two voltages. Fig.18.32 shows the circuit of an op-amp used as



**Fig. 18.32**

comparator.  $V_R$  is reference voltage which is connected with (+) terminal and  $V$  is the voltage which is to be compared with the reference  $V_R$ . It is connected with (-) terminal.

When  $V_i > V_+$  or  $V > V_R$ , then  $V_o = -V_{CC}$   
 and if  $V_i < V_+$  or  $V < V_R$ , then  $V_o = +V_{CC}$

**18.11 COMPARATOR AS A NIGHT SWITCH**

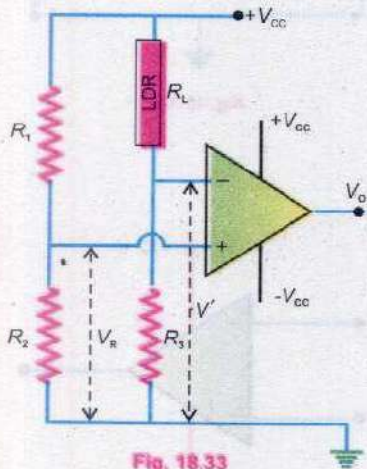
Suppose it is required that when intensity of light falls below a certain level, the street light is automatically switched on. This can be accomplished by using op-amp as a comparator. In Fig.18.33 resistances  $R_1$  and  $R_2$  form a potential divider. The potential drop across  $R_2$  provides the reference voltage  $V_R$  to the (+) input of the op-amp. Thus

$$V_R = \frac{R_2}{R_1 + R_2} \times V_{CC} \dots\dots\dots (18.8)$$

LDR is a light dependent resistance. The value of its resistance  $R_L$  depends upon the intensity of light falling upon it.  $R_L$  and  $R_3$  form another potential divider. The potential drop across  $R_3$  is  $V'$  which is given by

$$V' = \frac{R_3}{R_L + R_3} \times V_{CC} \dots\dots\dots (18.9)$$

$V'$  provides the voltage to (-) input of the op-amp.  $V'$  will not be



**Fig. 18.33**



a constant voltage but it will vary with the intensity of light. During day time, when light is falling upon LDR,  $R_L$  is small. According to Eq.18.9,  $V'$  will be large such that  $V' > V_R$  so that  $V_o = -V_{cc}$ . The output of the op is connected with a relay system which energizes only when  $V_o = +V_{cc}$  and then it turns on the street lights. Thus when  $V_o = -V_{cc}$ , the light will not be switched ON.

As it gets darker,  $R_L$  becomes larger and  $V'$  decreases. When  $V'$  becomes just less than  $V_R$ , the output of op-amp switches to  $+V_{cc}$  which energizes the relay system and the street lights are turned ON.

## 18.12 DIGITAL SYSTEMS

A digital system deals with quantities or variables which have only two discrete values or states. Following are the examples of such quantities.

- (i) A switch can be either open or closed.
- (ii) The answer of a question can be either yes or no.
- (iii) A certain statement can be either true or false.
- (iv) A bulb can be either off or on.

Various designations are used to represent the two quantized states of such quantities. The most common of these are listed in Table 18.1.

**Table 18.1**

	1	2	3	4	5	6
One of the states	True	High	1	Yes	On	Closed
The other state	False	Low	0	No	Off	Open

Mathematical manipulation of these quantities can be best carried if they are represented by binary digits 1 and 0. When we are dealing with voltages, designation No.2 is also a convenient representation.

In describing functions of digital systems a closed switch will be shown as 1 and open switch will be shown as 0. Similarly, a lighted bulb will be described as 1 and an off bulb will be described as 0.

Just as we require two basic mathematical operations, i.e., addition and subtraction for the mathematical manipulation



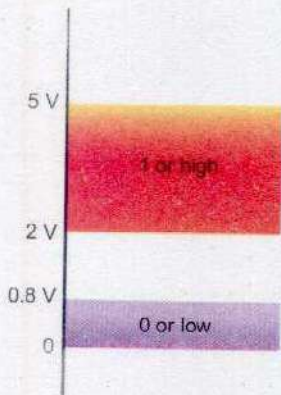
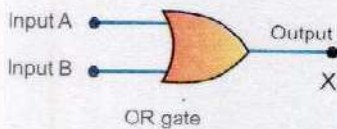


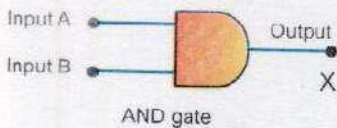
Fig. 18.34



OR gate

Fig. 18.35

A	B	Output
0	0	0
0	1	1
1	0	1
1	1	1



AND gate

Fig. 18.36

A	B	Output
0	0	0
0	1	0
1	0	0
1	1	1

of ordinary quantities which can possess all continuous values, we require a special algebra, known as Boolean algebra for the manipulation of the quantities which have values 1 and 0, now designated as Boolean variables. Boolean algebra is based upon three basic operations namely (i) AND operation, (ii) OR operation and (iii) NOT operation. You have already read about these operations. Here we would study about logic gates which implement these operations.

## 18.13 FUNDAMENTAL LOGIC GATES

The electronic circuits which implement the various logic operations are known as logic gates. In these gates the high and low states, i.e., 1 and 0 states are simulated by certain voltage levels. Ideally one particular voltage level represents a high (1) and another voltage level represents a low (0). In practical digital circuits, however a 1 or high can be any voltage between a specified minimum value and a specified maximum value. Likewise 0 or low can be any voltage between a specified minimum and a specified maximum. Fig. 18.34 shows the range 1 and 0 levels for a certain type of digital gates. Thus if voltage of 3.5 V is applied to a gate, it will accept it as high or 1. If a voltage of 0.5 V is applied, the gate will recognize it as 0 or low.

### OR Gate

OR gate as symbolically represented in Fig. 18.35, implements the logic of OR operation. It has two or more inputs and a single output X. The output has a value 1 when at least one of its inputs A and B is at 1. Thus X will be zero only when both the inputs are 0. Thus it implements the truth table of OR operation (Table 18.2). The mathematical notation for OR operation is

$$X = A + B$$

### AND Gate

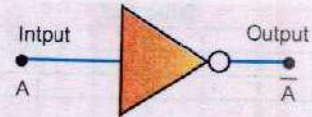
The AND gate shown in Fig. 18.36 has two or more inputs and a single output. It is designed such that it implements the truth table of AND operation, i.e., its output X is 1 only when both of its inputs A and B are at 1 and for all other combinations of the values of A and B, X is zero (Table 18.3). The mathematical notation for AND operation is

$$X = A \cdot B$$



## NOT Gate

It performs the operation of inversion or complementation. That is why it is also known as inverter. It changes a logic level to its opposite level, i.e., it changes 1 to 0 and 0 to 1. The symbolic representation of NOT gate is shown in Fig. 18.37. Whenever a bar is placed on any variable, it shows that the value of the variable has been inverted. For example  $\bar{1} = 0$  and  $\bar{0} = 1$ . The "bubble" (o) in Fig. 18.37 indicates operation of inversion. Its truth table is given in Table 18.4. The mathematical notation for NOT operation is  $X = \bar{A}$



NOT gate

Fig. 18.37

Table 18.4

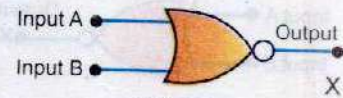
A	Output
0	1
1	0

## 18.14 OTHER LOGIC GATES

### NOR Gate

In NOR gate the output of OR gate is inverted. Its symbol is shown in Fig. 18.38 and its truth table is given in Table 18.5. The mathematical notation for NOR operation is

$$X = \overline{A + B}$$



NOR gate

Fig. 18.38

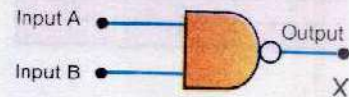
Table 18.5

A	B	Output
0	0	1
0	1	0
1	0	0
1	1	0

### NAND Gate

In NAND gate the output of an AND gate is inverted. Its symbol is shown in Fig. 18.39. The bubble in this figure shows that the output of AND gate is inverted. The truth table implemented by it is shown in Table 18.6. The mathematical notation for NAND operation is

$$X = \overline{A \cdot B}$$



NAND gate

Fig. 18.39

Table 18.6

A	B	Output
0	0	1
0	1	1
1	0	1
1	1	0

### Exclusive OR Gate (XOR)

Consider a Boolean function  $X$  of two variables  $A$  and  $B$  such that

$$X = A\bar{B} + \bar{A}B$$

The first term of the function  $X$  is obtained by ANDing the variable  $A$  with NOT of  $B$ . The second term is NOT of  $A$  ANDed with  $B$ . The function  $X$  is obtained by ORing these two terms. It can be constructed by combining AND, OR and NOT gates according to the scheme shown in Fig. 18.40(a). The

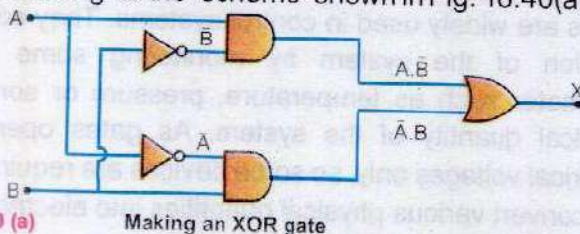


Fig. 18.40 (a)

Making an XOR gate



A	B	Output
0	0	0
1	0	1
0	1	1
1	1	0

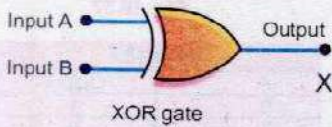


Fig. 18.40 (b)

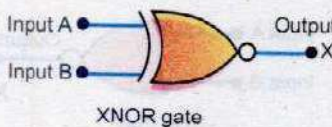


Fig. 18.41

A	B	Output
0	0	1
0	1	0
1	0	0
1	1	1

value of this function can be obtained by drawing the truth table (Table 18.7) which gives the value of X for all the values of the variables A and B. The value of X is 0 when the two inputs have the same values and it is 1 when the inputs have different values. It can be verified that the circuit of Fig. 18.40 (a) implements this truth table. The symbol of XOR gate is shown in Fig. 18.40(b).

### Exclusive - NOR gate (XNOR)

The exclusive NOR gate is obtained by inverting the output of a XOR gate. Its symbol is shown in Fig. 18.41. The bubble shown at the output in this figure shows that the output of XOR gate has been inverted. So its Boolean expression is given by

$$X = \overline{A\bar{B}} + \overline{\bar{A}B}$$

The truth table of XNOR gate is given in the Table 18.8. Its output is 1 when its two inputs are identical and 0 when the two inputs are different. Like XOR gate, it is also constructed by a combination of NOT, AND and NOR gates by the scheme shown in Fig.18.42.

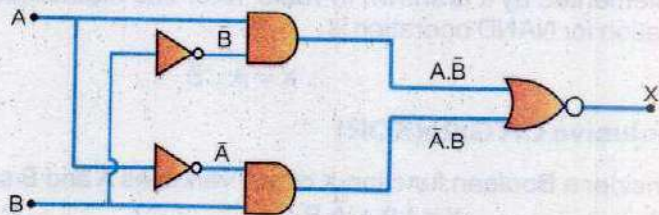


Fig. 18.42

## 18.15 APPLICATIONS OF GATES IN CONTROL SYSTEMS

Gates are widely used in control systems. They control the function of the system by monitoring some physical parameter such as temperature, pressure or some other physical quantity of the system. As gates operate with electrical voltages only, so some devices are required which can convert various physical quantities into electric voltage.



These devices are known as sensors. For example, in the example of night switch, Light Dependent Resistance (LDR) is a sensor for light because it can convert changes in the intensity of light into electric voltage. A thermister is a sensor for temperature. A microphone is a sound sensor. Similarly there are level sensors which give an electrical signal when the level of liquid in a vessel attains a certain limit. One such application is described here. For example sensors are used to monitor the pressure and temperature of a chemical solution stored in a vat. The circuitry for each sensor is such that it produces a HIGH, i.e., 1 when either the temperature or pressure exceeds a specified value. A circuit is to be designed which will ring an alarm when either the temperature or pressure or both cross the maximum specified limit. The alarm requires a LOW(0) voltage for its activation.

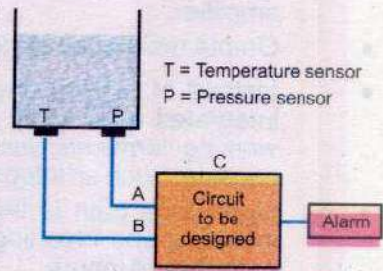


Fig. 18.43

**Table 18.9**

A	B	C
0	0	1
0	1	0
1	0	0
1	1	0

The block diagram of the problem is shown in Fig.18.43 in which C is the circuit to be designed. Its inputs A and B are fed by the temperature and pressure sensors T and P fitted into the vat. Whenever output of the circuit C is LOW, the alarm is activated. So the circuit C should be such that its output is 0 as soon as the limit for temperature or pressure is exceeded, i.e., when A = 0, B = 1 or when A = 1, B = 0 or when A = B = 1. The output of C should be HIGH when temperature and pressure are within the specified limit, i.e., when A = B = 0. This gives the truth table 18.9 which the circuit C has to implement. It can be seen that it is the truth table of NOR gate. So the circuit C in Fig.18.43 should be a NOR gate as shown in Fig.18.44.

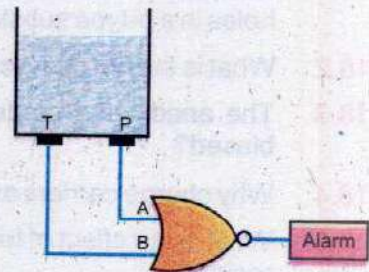


Fig. 18.44

### SUMMARY

- When an external potential difference is applied across a p-n junction such that p-side is positive and n-side is negative, it is called forward biased.
- When the external source of voltage is applied across a p-n junction such that its positive terminal is connected to n-region and its negative terminal to p-region, the p-n junction is said to be reverse biased.
- Conversion of alternating current into direct current is called rectification.
- When only one half of alternating current cycle is converted into direct current, it is called half-wave rectification.
- Transistor is a semiconductor device consisting of three electrodes, namely emitter, base and collector. For normal operation, the base-emitter junction is forward biased whereas the collector-base junction is reverse biased.



- Input resistance is the resistance between the positive and negative inputs of the amplifier.
- Output resistance is the resistance between the output terminal and ground.
- Instead of making amplifier circuit by discrete components, the whole amplifier is integrated on a small silicon chip and enclosed in a capsule. Pins connected with working terminals such as inputs, outputs and power supply project outside the capsule. Such an integrated amplifier is known as operational amplifier.
- Open loop gain is the ratio of output voltage and the difference between non-inverting and inverting inputs when there is no external connection between the outputs and inputs.
- A digital system deals with quantities or variables which have only two discrete values or states.
- The electronic circuits which implement the various logic operations are known as logic gates.

### QUESTIONS

- 18.1 How does the motion of an electron in a n-type substance differ from the motion of holes in a p-type substance?
- 18.2 What is the net charge on a n-type or a p-type substance?
- 18.3 The anode of a diode is 0.2 V positive with respect to its cathode. Is it forward biased?
- 18.4 Why charge carriers are not present in the depletion region?
- 18.5 What is the effect of forward and reverse biasing of a diode on the width of depletion region?
- 18.6 Why ordinary silicon diodes do not emit light?
- 18.7 Why a photo diode is operated in reverse biased state?
- 18.8 Why is the base current in a transistor very small?
- 18.9 What is the biasing requirement of the junctions of a transistor for its normal operation? Explain how these requirements are met in a common emitter amplifier?
- 18.10 What is the principle of virtual ground? Apply it to find the gain of an inverting amplifier.
- 18.11 The inputs of a gate are 1 and 0. Identify the gate if its output is (a) 0, (b) 1
- 18.12 Tick (✓) the correct answer
- (i) A diode characteristic curve is a plot between
- |                         |   |
|-------------------------|---|
| (a) current and time    | (b) voltage and time                    |
| (c) voltage and current | (d) forward voltage and reverse voltage |



- (ii). The colour of light emitted by a LED depends on
- (a) its forward bias
  - (b) its reverse bias
  - (c) the amount of forward current
  - (d) the type of semi-conductor material used.

- (iii) In a half-wave rectifier the diode conducts during
- a. both halves of the input cycle
  - b. a portion of the positive half of the input cycle
  - c. a portion of the negative half of the input cycle
  - d. One half of the input cycle

- (iv) In a bridge rectifier of Fig. Q. 18.1 when  $V_1$  is positive at point B with respect to point A, which diodes are ON.

- a.  $D_2$  and  $D_4$
- b.  $D_1$  and  $D_3$
- c.  $D_2$  and  $D_3$
- d.  $D_1$  and  $D_4$

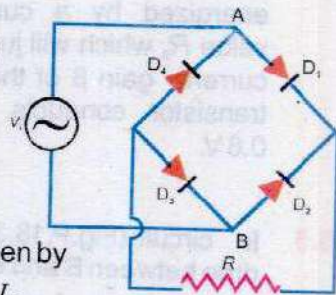


Fig. Q. 18.1

- (v) The common emitter current amplification factor  $\beta$  is given by
- a.  $\frac{I_C}{I_E}$
  - b.  $\frac{I_C}{I_B}$
  - c.  $\frac{I_E}{I_B}$
  - d.  $\frac{I_B}{I_E}$

- (vi) Truth table of logic function
- a. summarizes its output values
  - b. tabulates all its input conditions only
  - c. display all its input/output possibilities
  - d. is not based on logic algebra

- (vii) The output of a two inputs OR gate is 0 only when its
- a. both inputs are 0
  - b. either input is 1
  - c. both inputs are 1
  - d. either input is 0

- (viii) A two inputs NAND gate with inputs A and B has an output 0 if
- a. A is 0
  - b. B is 0
  - c. both A and B are zero
  - d. both A and B are 1

- (ix) The truth table shown below is for

- a. XNOR gate
- b. OR gate
- c. AND gate
- d. NAND gate

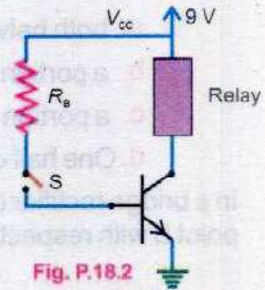
A	B	X
0	0	1
0	1	0
1	0	0
1	1	1



## PROBLEMS

**18.1** The current flowing into the base of a transistor is  $100 \mu\text{A}$ . Find its collector current  $I_C$ , its emitter current  $I_E$  and the ratio  $I_C/I_E$ , if the value of current gain  $\beta$  is 100. **(Ans: 10 mA, 10.1 mA, 0.99)**

**18.2** Fig.P.18.2 shows a transistor which operates a relay as the switch  $S$  is closed. The relay is energized by a current of  $10 \text{ mA}$ . Calculate the value  $R_B$  which will just make the relay operate. The current gain  $\beta$  of the transistor is 200. When the transistor conducts, its  $V_{BE}$  can be assumed to be  $0.6 \text{ V}$ . **(Ans: 168 k $\Omega$ )**

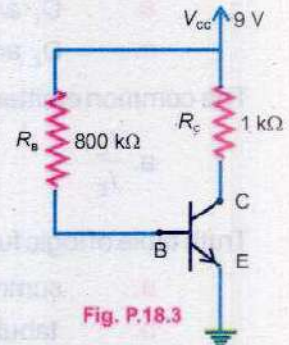


**Fig. P.18.2**

**18.3** In circuit (Fig.P.18.3), there is negligible potential drop between B and E, if  $\beta$  is 100. Calculate

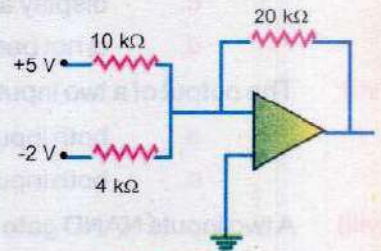
- (i) base current
- (ii) collector current
- (iii) potential drop across  $R_C$
- (iv)  $V_{CE}$

**(Ans: 11.25  $\mu\text{A}$ , 1.125 mA, 1.125 V, 7.875 V)**



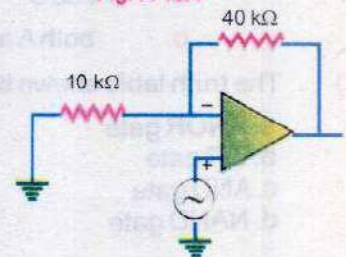
**Fig. P.18.3**

**18.4** Calculate the output of the op-amp circuit shown in Fig.P.18.4. **(Ans: 0)**



**Fig. P. 18.4**

**18.5** Calculate the gain of non-inverting amplifier shown in Fig.P.18.5. **(Ans: 5)**



**Fig. P. 18.5**



# Chapter 19

## DAWN OF MODERN PHYSICS

### Learning Objectives

At the end of this chapter the students will be able to:

1. Distinguish between inertial and non-inertial frames of references.
2. Describe the postulates of special theory of relativity and its results.
3. Understand the NAVASTAR navigation system.
4. Understand the concept of black body radiation.
5. Understand and describe how energy is distributed over the wavelength range for several values of source temperature.
6. Know Planck's assumptions.
7. Know the origin of quantum theory.
8. Show an appreciation of the particle nature of electromagnetic radiation.
9. Describe the phenomenon of photoelectric effect.
10. Explain photoelectric effect in terms of photon energy and work function.
11. Explain the function of photocell and describe its uses.
12. Describe Compton's effect.
13. Explain the phenomena of pair production and pair annihilation.
14. Describe de-Broglie's hypothesis of wave nature of particles.
15. Describe and interpret qualitatively the evidence provided by electron diffraction for the wave nature of particles.
16. Understand the working principle of electron microscope.
17. Understand and describe uncertainty principle.

In the early part of the twentieth century, many experimental and theoretical problems remained unresolved. Attempts to explain the behaviour of matter on the atomic level with the laws of classical physics were not successful. Phenomena such as black body radiation, the photoelectric effect, the emission of sharp spectral lines by atoms in a gas discharge tube, and invariance of speed of light, could not be understood within the framework of classical physics. To explain these observations a revolutionary framework of explanation was necessary which we call modern physics. Its two most significant features are relativity and quantum theory. The observations on objects moving very fast, approaching the speed of light, are well explained by the special theory of relativity. Quantum theory has been able to explain the behaviour of electromagnetic radiation as discrete packets of energy and the particles on a very small scale are dominated by wave properties.

Classical physics is still valid in ordinary processes of everyday life. But to explain the behaviour of tiny or very fast moving particles, we have to use the above mentioned theories. In this chapter, we shall discuss various aspects of theory of relativity and quantum



theory. Before introducing special theory of relativity, some related terms are discussed briefly.

## 19.1 RELATIVE MOTION

When we say a ball is thrown up, the 'up' direction is only for that particular place. It will be 'down' position for a person on the diametrically opposite side of the globe. The concept of direction is purely relative. Similarly, the rest position or the motion of an object is not same for different observers. For example, the walls of the cabin of a moving train are stationary with respect to the passengers sitting inside it but are in motion to a person stationary on the ground. So we cannot say whether an object is absolutely at rest or absolutely in motion. All motions are relative to a person or instrument observing it.

Let us perform an experiment in two cars moving with constant velocities in any direction. Suppose a ball is thrown straight up. It will come back straight down. This will happen in both cars. But if a person in one car observes the experiment done in the other car, will he observe the same? Suppose now one car is stationary. The person in the other car, which is moving with constant velocity, throws a ball straight up. He will receive the ball straight down. On the other hand, the fellow sitting in the stationary car observes that the path of the ball is a parabola. Thus, when experimenters observe what is going on in their own frame of reference, the same experiment gives identical observations. But if they look into other frames, they observe differently.

## 19.2 FRAMES OF REFERENCE

We have discussed the most commonly used Cartesian coordinate system. In effect, a frame of reference is any coordinate system relative to which measurements are taken. The position of a table in a room can be located relative to the walls of the room. The room is then the frame of reference. For measurements taken in the college laboratory, the laboratory is the reference frame. If the same experiment is performed in a moving train, the train becomes a frame of reference. The position of a spaceship can be described relative to the positions of the distant stars. A coordinate system based on these stars is then the frame of reference.

An inertial frame of reference is defined as a coordinate system in which the law of inertia is valid. That is, a body at



rest remains at rest unless an unbalanced force produces acceleration in it. Other laws of nature also apply in such a system. If we place a body upon Earth it remains at rest unless an unbalanced force is applied upon it. This observation shows that Earth may be considered as an inertial frame of reference. A body placed in a car moving with a uniform velocity with respect to Earth also remains at rest, so that car is also an inertial frame of reference. Thus any frame of reference which is moving with uniform velocity relative to an inertial frame is also an inertial frame.

When the moving car is suddenly stopped, the body placed in it, no longer remains at rest. So is the case when the car is suddenly accelerated. In such a situation, the car is not an inertial frame of reference. Thus an accelerated frame is a non-inertial frame of reference. Earth is rotating and revolving and hence strictly speaking, the Earth is not an inertial frame. But it can often be treated as an inertial frame without serious error because of very small acceleration.

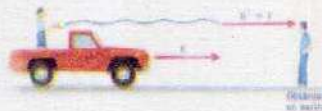
### 19.3 SPECIAL THEORY OF RELATIVITY

The theory of relativity is concerned with the way in which observers who are in a state of relative motion describe physical phenomena. The special theory of relativity treats problems involving inertial or non-accelerating frames of reference. There is another theory called general theory of relativity which treats problems involving frames of reference accelerating with respect to one another. The special theory of relativity is based upon two postulates, which can be stated as follows:

1. The laws of physics are the same in all inertial frames.
2. The speed of light in free space has the same value for all observers, regardless of their state of motion.

The first postulate is the generalization of the fact that all physical laws are the same in frames of reference moving with uniform velocity with respect to one another. If the laws of physics were different for different observers in relative motion, the observer could determine from this difference that which of them were stationary in a space and which were moving. But such a distinction does not exist, so this postulate implies that there is no way to detect absolute uniform motion. The second postulate states an experimental fact that speed of light in free space is the universal constant 'c' ( $c = 3 \times 10^8 \text{ ms}^{-1}$ ). These simple postulates have far-reaching consequences. These

#### Do You Know?



The speed of light emitted by flashlight is  $c$  measured by two observers, one on the moving track and the other on the road.



include such phenomena as the slowing down of clocks and contraction of lengths in moving reference frames as measured by a stationary observer. Some interesting results of the special theory of relativity can be summarized as follows without going into their mathematical derivations.

### Time Dilation

According to special theory of relativity, time is not absolute quantity. It depends upon the motion of the frame of reference.

Suppose an observer is stationary in an inertial frame. He measures the time interval between two events in this frame. Let it be  $t_0$ . This is known as proper time. If the observer is moving with respect to frame of events with velocity  $v$  or if the frame of events is moving with respect to observer with a uniform velocity  $v$ , the time measured by the observer would not be  $t_0$ , but it would be  $t$  given by

$$t = \frac{t_0}{\sqrt{1 - \frac{v^2}{c^2}}} \dots\dots\dots (19.1)$$

As the quantity  $\sqrt{1 - \frac{v^2}{c^2}}$  is always less than one, so  $t$  is greater than  $t_0$ , i.e., time has dilated or stretched due to relative motion of the observer and the frame of reference of events. This astonishing result applies to all timing processes -- physical, chemical and biological. Even aging process of the human body is slowed by motion at very high speeds.

### Length Contraction

The distance from Earth to a star measured by an observer in a moving spaceship would seem smaller than the distance measured by an observer on Earth. That is, if you are in motion relative to two points that are a fixed distance apart, the distance between the two points appears shorter than if you were at rest relative to them. This effect is known as length contraction. The length contraction happens only along the direction of motion. No such contraction would be observed perpendicular to the direction of motion. The length of an object or distance between two points measured by an observer who is relatively at rest is called proper length  $l_0$ . If an object and an observer are in relative motion with speed  $v$ , then the contracted length  $l$  is given by



$$l = l_0 \sqrt{1 - \frac{v^2}{c^2}} \quad \dots\dots\dots (19.2)$$

### Mass Variation

According to special theory of relativity, mass of an object is a varying quantity and depends upon the speed of the object. An object whose mass when measured at rest is  $m_0$  will have an increased mass  $m$  when observed to be moving at speed  $v$ . They are related by

$$m = \frac{m_0}{\sqrt{1 - \frac{v^2}{c^2}}} \quad \dots\dots\dots (19.3)$$

The increase in mass indicates the increase in inertia the object has at high speeds. As  $v$  approaches  $c$ , it requires a larger and larger force to change the speed of the object.

As  $v \rightarrow c, \frac{v}{c} \rightarrow 1$  therefore  $\sqrt{1 - \frac{v^2}{c^2}} \rightarrow 0$

Thus  $m \rightarrow \infty$

An infinite mass would require an infinite force to accelerate it. Because infinite forces are not available, hence, an object cannot be accelerated to the speed of light ' $c$ ' in free space.

In our everyday life, we deal with extremely small speeds, compared to the speed of light. Even the Earth's orbital speed is only  $30 \text{ kms}^{-1}$ . On the other hand, the speed of light in free space is  $300,000 \text{ kms}^{-1}$ . This is the reason why Newton's laws are valid in everyday situations. However, when experimenting with atomic particles moving with velocities approaching speed of light, the relativistic effects are very prominent, and experimental results cannot be explained without taking Einstein's equations into account.

### Energy - Mass Relation

According to special theory of relativity, mass and energy are different entities but are interconvertible. The total energy  $E$  and mass  $m$  of an object are related by the expression

$$E = mc^2 \quad \dots\dots\dots (19.4)$$

where  $m$  depends on the speed of the object. At rest, the energy equivalent of an object's mass  $m_0$  is called rest mass energy  $E_0$ .



$$E_0 = m_0 c^2 \quad \dots\dots\dots (19.5)$$

As  $mc^2$  is greater than  $m_0c^2$ , the difference of energy ( $mc^2 - m_0c^2$ ) is due to motion, as such it represents the kinetic energy of the mass. Hence

$$K.E. = (m - m_0)c^2 \quad \dots\dots\dots (19.6)$$

From equation 19.4 above, the change in mass  $m$  due to change in energy  $\Delta E$  is given by

$$\Delta m = \frac{\Delta E}{c^2}$$

Because  $c^2$  is a very large quantity, this implies that small changes in mass require very large changes in energy. In our everyday world, energy changes are too small to provide measurable mass changes. However, energy and mass changes in nuclear reactions are found to be exactly in accordance with the above mentioned equations.

**NAVSTAR Navigation System**

The results of special theory of relativity are put to practical use even in everyday life by a modern system of navigation satellites called NAVSTAR. The location and speed anywhere on Earth can now be determined to an accuracy of about 2 cms<sup>-1</sup>. However, if relativity effects are not taken into account, speed could not be determined any closer than about 20 cms<sup>-1</sup>. Using these results the location of an aircraft after an hour's flight can be predicted to about 50 m as compared to about 760 m determined by without using relativistic effects.

**Example 19.1:** The period of a pendulum is measured to be 3.0 s in the inertial reference frame of the pendulum. What is its period measured by an observer moving at a speed of 0.95 c with respect to the pendulum?

**Solution:**

$$t_0 = 3.0 \text{ s}, \quad v = 0.95 c, \quad t = ?$$

Using

$$t = \frac{t_0}{\sqrt{1 - \frac{v^2}{c^2}}}$$

$$t = \frac{3.0 \text{ s}}{\sqrt{1 - \frac{(0.95 c)^2}{c^2}}} = \frac{3.0 \text{ s}}{\sqrt{1 - (0.95)^2}} = 9.6 \text{ s}$$



**Example 19.2:** A bar 1.0 m in length and located along x-axis moves with a speed of  $0.75c$  with respect to a stationary observer. What is the length of the bar as measured by the stationary observer?

**Solution:**

$$l_0 = 1.0 \text{ m}, \quad v = 0.75c, \quad l = ?$$

Using 
$$l = l_0 \sqrt{1 - \frac{v^2}{c^2}}$$

$$l = 1.0 \text{ m} \times \sqrt{1 - \frac{(0.75c)^2}{c^2}} = 1.0 \text{ m} \times \sqrt{1 - (0.75)^2} = 0.66 \text{ m}$$

**Example 19.3:** Find the mass  $m$  of a moving object with speed  $0.8c$ .

**Solution:**

Using 
$$m = \frac{m_0}{\sqrt{1 - \frac{v^2}{c^2}}}$$

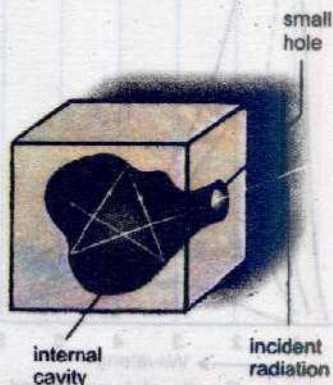
or 
$$m = \frac{m_0}{\sqrt{1 - \frac{(0.8c)^2}{c^2}}} = \frac{m_0}{\sqrt{1 - (0.8)^2}} = 1.67 m_0$$

or 
$$m = 1.67 m_0$$

## 19.4 BLACK BODY RADIATION

When a body is heated, it emits radiation. The nature of radiation depends upon the temperature. At low temperature, a body emits radiation which is principally of long wavelengths in the invisible infrared region. At high temperature, the proportion of shorter wavelength radiation increases. Furthermore, the amount of emitted radiation is different for different wavelengths. It is of interest to see how the energy is distributed among different wavelengths at various temperatures. For example, when platinum wire is heated, it appears dull red at about  $500^\circ\text{C}$ , changes to cherry red at  $900^\circ\text{C}$ , becomes orange red at  $1100^\circ\text{C}$ , yellow at  $1300^\circ\text{C}$  and finally white at about  $1600^\circ\text{C}$ . This shows that as the temperature is increased, the radiation becomes richer in shorter wavelengths.

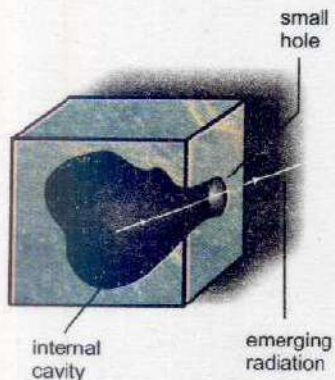
In order to understand the distribution of radiation emitted from a hot body, we consider a non-reflecting object such as a solid



(a) Absorption of radiation

Fig. 19.1





(b) Emission of radiation

Fig. 19.1

that has a hollow cavity within it. It has a small hole and the radiation can enter or escape only through this hole. The inside is blackened with soot to make it as good an absorber and as bad a reflector as possible. The small hole appears black because the radiation that enters is reflected from the inside walls many times and is partly absorbed at each reflection until none remains. Such a body is termed as black body and has the property to absorb all the radiation entering it. A black body is both an ideal absorber (Fig. 19.1 a) and an ideal radiator (Fig. 19.1 b).

### Intensity Distribution Diagram

Lummer and Pringsheim measured the intensity of emitted energy with wavelength radiated from a black body at different temperatures by the apparatus shown in Fig. 19.2. The amount of radiation emitted with different wavelengths is shown in the form of energy distribution curves for each temperature in the Fig. 19.3.

### For Your Information

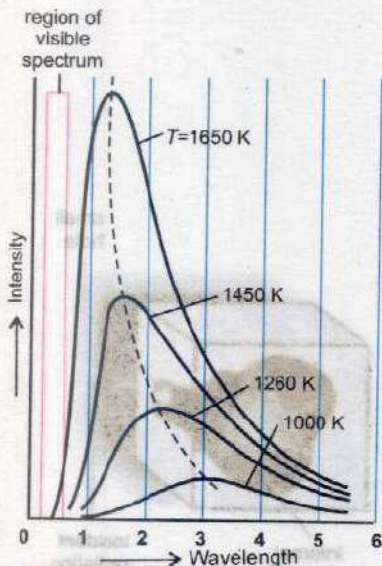


Fig 19.3 Results of Lummer and Pringsheim's experiments: graphs of intensity of radiated energy against wavelength from a blackbody

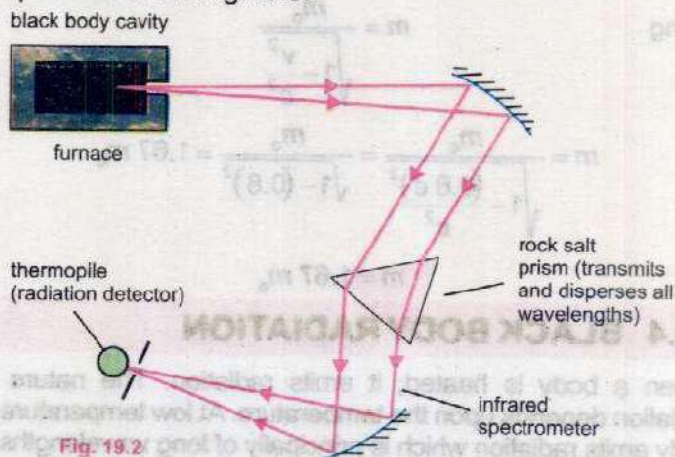


Fig. 19.2

These curves reveal the following interesting facts.

1. At a given temperature, the energy is not uniformly distributed in the radiation spectrum of the body.
2. At a given temperature  $T$ , the emitted energy has maximum value for a certain wavelength  $\lambda_{\max}$  and the product  $\lambda_{\max} \times T$  remains constant.

$$\lambda_{\max} \times T = \text{Constant} \quad \dots \dots \dots (19.7)$$

The value of the constant known as Wien's constant is about  $2.9 \times 10^{-3} \text{ m K}$ . This equation means that as  $T$



increases,  $\lambda_{\text{max}}$  shifts to shorter wavelength.

3. For all wavelengths, an increase in temperature causes an increase in energy emission. The radiation intensity increases with increase in wavelengths and at a particular wavelength  $\lambda_{\text{max}}$ , it has a maximum value. With further increase in wavelength, the intensity decreases.
4. The area under each curve represents the total energy ( $E$ ) radiated per second per square metre over all wavelengths at a particular temperature. It is found that area is directly proportional to the fourth power of kelvin temperature  $T$ . Thus

$$E \propto T^4 \quad \text{or} \quad E = \sigma T^4 \quad \dots\dots\dots (19.8)$$

where  $\sigma$  is called Stefan's constant. Its value is  $5.67 \times 10^{-8} \text{ Wm}^{-2}\text{K}^{-4}$  and the above relation is known as Stefan-Boltzmann law.

### Planck's Assumption

Electromagnetic wave theory of radiation cannot explain the energy distribution along the intensity-wavelengths curves. The successful attempts to explain the shape of energy distribution curves gave rise to a new and non-classical view of electromagnetic radiation. In 1900, Max Planck founded a mathematical model resulting in an equation that describes the shape of observed curves exactly. He suggested that energy is radiated or absorbed in discrete packets, called quanta rather than as a continuous wave. Each quantum is associated with radiation of a single frequency. The energy  $E$  of each quantum is proportional to its frequency  $f$ , and

$$E = hf \quad \dots\dots\dots (19.9)$$

where  $h$  is Planck's constant. Its value is  $6.63 \times 10^{-34} \text{ Js}$ . This fundamental constant is as important in physics as the constant  $c$ , the speed of light in vacuum.

Max Planck received the Nobel Prize in physics in 1918 for his discovery of energy quanta.

### The Photon

Planck suggested that as matter is not continuous but consists of a large number of tiny particles, so is the radiation energy from a source. He assumed that granular nature of



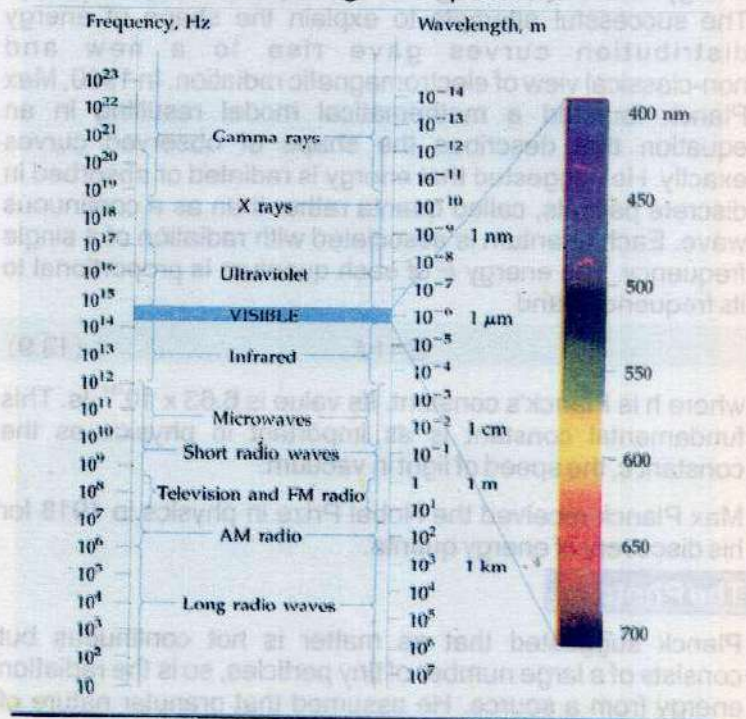
radiation from hot bodies was due to some property of the atoms producing it. Einstein extended his idea and postulated that packets or tiny bundles of energy are integral part of all electromagnetic radiation and that they could not be subdivided. These indivisible tiny bundles of energy he called photons. The beam of light with wavelength  $\lambda$  consists of stream of photons travelling at speed  $c$  and carries energy  $hf$ . From the theory of relativity momentum  $p$  of the photon is related to energy as

$$E = pc \quad \dots\dots\dots (19.10)$$

$$\text{Thus } pc = hf \quad \text{or} \quad p = \frac{hf}{c} = \frac{h}{\lambda} \quad \dots\dots\dots (19.11)$$

The table 19.1 relates the quanta emitted in different regions of the electromagnetic spectrum with energy. At the high end,  $\gamma$ - radiation with energy  $\sim 1$  MeV is easily detected as quanta by a radiation detector and counter. At the other end, the energy of photon of radio waves is only about  $10^{-10}$  eV. So millions of photons are needed to detect a signal and hence wave properties of radio waves predominate. The quanta are

Table: 19.1 Electromagnetic spectrum





so close together in energy value that radio waves are detected as continuous radiation.

The emission or absorption of energy in steps may be extended to include any system such as a mass oscillating on a spring. However, the energy steps are far too small to be detected and so any granular nature is invisible. Quantum effects are only important when observing atomic sized objects, where  $h$  is a significant factor in any detectable energy change.

**Example 19.4:** Assuming you radiate as does a blackbody at your body temperature about  $37^\circ\text{C}$ , at what wavelength do you emit the most energy?

**Solution:**

$$T = 37^\circ\text{C} = 310\text{ K}$$

$$\text{Wien's constant} = 2.9 \times 10^{-3} \text{ mK}$$

$$\lambda_{\text{max}} = ?$$

$$\text{Using } \lambda_{\text{max}} \times T = \text{Constant}$$

$$\lambda_{\text{max}} = \frac{2.9 \times 10^{-3} \text{ mK}}{310 \text{ K}} = 9.35 \times 10^{-6} \text{ m} = 9.35 \mu\text{m}$$

The radiation lies in the invisible infrared region and is independent of skin colour.

**Example 19.5:** What is the energy of a photon in a beam of infrared radiation of wavelength  $1240 \text{ nm}$ ?

**Solution:**

$$\lambda = 1240 \text{ nm}, \quad E = ?$$

$$\text{Using } E = hf = \frac{hc}{\lambda}$$

$$E = \frac{6.63 \times 10^{-34} \text{ Js} \times 3 \times 10^8 \text{ ms}^{-1}}{1240 \times 10^{-9} \text{ m}} = 1.6 \times 10^{-19} \text{ J}$$

$$\text{or } E = 1.0 \text{ eV}$$

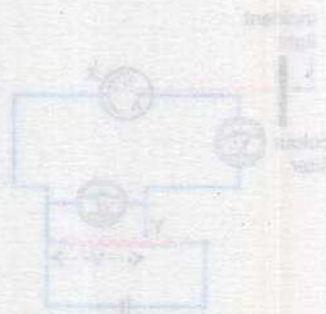


Figure 19.1: A circuit for measuring the current and voltage across a blackbody radiator.



Figure 19.2: A graph showing the relationship between current (I) and voltage (V) for a blackbody radiator. The slope is 1/V.

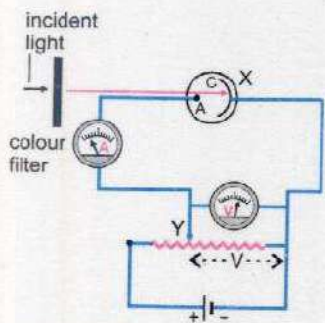


Figure 19.3: A graph showing the relationship between current (I) and voltage (V) for a blackbody radiator. The slope is 1/V.

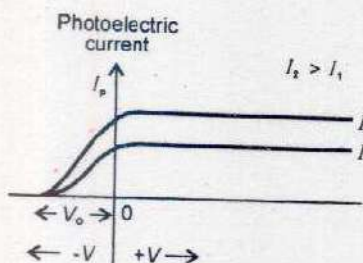
## 19.5 INTERACTION OF ELECTROMAGNETIC RADIATION WITH MATTER

Electromagnetic radiation or photons interact with matter in three distinct ways depending mainly on their energy. The three processes are

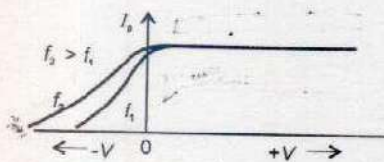




**Fig 19.4** Experimental arrangement to observe photoelectric effect.



**Fig 19.5** Characteristic curves of photocurrent vs. applied voltage for two intensities of monochromatic light.



**Fig 19.6** Characteristic curves of photocurrent vs. applied voltage for light of different frequencies.

- (i) Photoelectric effect
- (ii) Compton effect
- (iii) Pair production

## Photoelectric Effect

The emission of electrons from a metal surface when exposed to light of suitable frequency is called the photoelectric effect. The emitted electrons are known as photoelectrons.

The photoelectric effect is demonstrated by the apparatus shown in Fig. 19.4. An evacuated glass tube X contains two electrodes. The electrode A connected to the positive terminal of the battery is known as anode. The electrode C connected to negative terminal is known as cathode. When monochromatic light is allowed to shine on cathode, it begins to emit electrons. These photoelectrons are attracted by the positive anode and the resulting current is measured by an ammeter. The current stops when light is cut off, which proves, that the current flows because of incident light. This current is, hence, called photoelectric current. The maximum energy of the photoelectrons can be determined by reversing the connection of the battery in the circuit i.e., now the anode A is negative and cathode C is at positive potential. In this condition the photoelectrons are repelled by the anode and the photoelectric current decreases. If this potential is made more and more negative, at a certain value, called stopping potential  $V_0$ , the current becomes zero. Even the electrons of maximum energy are not able to reach collector plate. The maximum energy of photoelectrons is thus

$$\frac{1}{2}mv_{\max}^2 = V_0e$$

where  $m$  is mass,  $v$  is velocity and  $e$  is the charge on electron. If the experiment is repeated with light beam of higher intensity, the amount of current increases but the current stops for the same value of  $V_0$ . The Fig.19.5 shows two curves of photoelectric current as a function of potential  $V$  where  $I_2 > I_1$ . If, however, the intensity is kept constant and experiment is performed with different frequencies of incident light, we obtain the curves shown in Fig.19.6. The current is same but stopping potential is different for each frequency of incident light, which indicates the proportionality of maximum kinetic energy with frequency of light  $f$ .



The important results of the experiments are

1. The electrons are emitted with different energies. The maximum energy of photoelectrons depends on the particular metal surface and the frequency of incident light.
2. There is a minimum frequency below which no electrons are emitted, however intense the light may be. This threshold frequency  $f_0$  varies from metal to metal.
3. Electrons are emitted instantaneously, the intensity of light determines only their number.

These results could not be explained on the basis of electromagnetic wave theory of light. According to this theory, increasing the intensity of incident light should increase the K.E. of emitted electrons which contradicts the experimental result. The classical theory cannot also explain the threshold frequency of light.

### Explanation on the Basis of Quantum Theory

Einstein extended the idea of quantization of energy proposed by Max Planck that light is emitted or absorbed in quanta, known as photons. The energy of each photon of frequency  $f$  as given by quantum theory is

$$E = hf$$

A photon could be absorbed by a single electron in the metal surface. The electron needs a certain minimum energy called the work function ' $\Phi$ ' to escape from the metal surface. If the energy of incident photon is sufficient, the electron is ejected instantaneously from the metal surface. A part of the photon energy (work function) is used by the electron to break away from the metal and the rest appears as the kinetic energy of the electron. That is,

Incident photon energy - Work function = Max. K.E. of photoelectron

$$\text{or } hf - \Phi = \frac{1}{2}mv_{\text{max}}^2 \quad \dots\dots\dots (19.12)$$

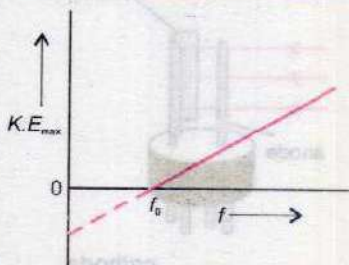
This is known as Einstein's photoelectric equation.

When  $K.E_{\text{max}}$  of the photoelectron is zero, the frequency  $f$  is equal to threshold frequency  $f_0$ , hence the Eq.19.12 becomes

$$hf_0 - \Phi = 0 \quad \text{or} \quad \Phi = hf_0 \quad \dots\dots\dots (19.13)$$

Hence, we can also write Einstein's photoelectric equation as

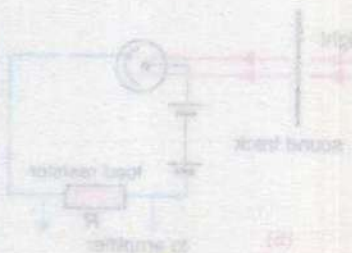
### For Your Information



A graph of the maximum kinetic energy of photoelectrons vs. light frequency. Below a certain frequency,  $f_0$ , no photoemission occurs.



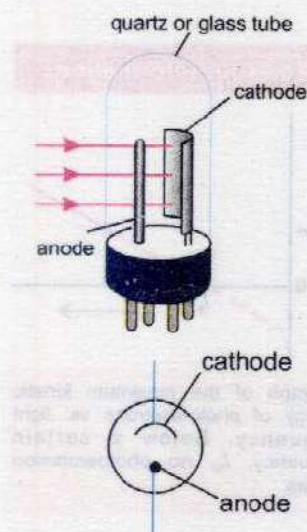
Diagram illustrating the experimental setup for the photoelectric effect.



Circuit diagram for the photoelectric effect experiment.



$$K.E_{\max} = hf - hf_0 \dots\dots\dots (19.14)$$

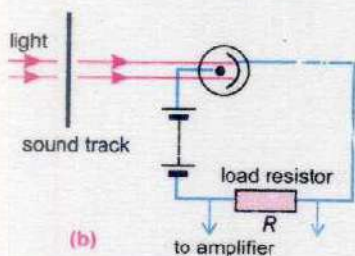


**Fig 19.7** Simple photo-emissive cell



(a)

**Fig 19.8** Sound track on a film which varies the intensity of light reaching the photo cell.



(b)

**Fig. 19.8** Photocell detection circuit for sound track of movies.

It is to be noted that all the emitted electrons do not possess the maximum kinetic energy, some electrons come straight out of the metal surface and some lose energy in atomic collisions before coming out. The equation 19.14 holds good only for those electrons which come out with full surplus energy.

Albert Einstein was awarded Nobel Prize in physics in 1921 for his explanation of photoelectric effect.

Note that the phenomenon of photoelectric effect cannot be explained if we assume that light consists of waves and energy is uniformly distributed over its wavefront. It can only be explained by assuming light consists of corpuscles of energy known as photon. Thus it shows the corpuscular nature of light.

### Photocell

A photocell is based on photoelectric effect. A simple photocell is shown in Fig. 19.7. It consists of an evacuated glass bulb with a thin anode rod and a cathode of an appropriate metal surface. The material of the cathode is selected to suit to the frequency range of incident radiation over which the cell is operated. For example sodium or potassium cathode emits electrons for visible light, cesium coated oxidized silver emits electrons for infrared light and some other metals respond to ultraviolet radiation. When photo-emissive surface is exposed to appropriate light (Fig.19.8 a), electrons are emitted and a current flows in the external circuit which increases with the increase in light intensity. The current stops when the light beam is interrupted. The cell has wide range of applications. Some of these are to operate:

1. Security systems
2. Counting systems
3. Automatic door systems
4. Automatic street lighting
5. Exposure meter for photography
6. Sound track of movies (Fig.19.8 b)

**Example 19.6:** A sodium surface is illuminated with light of wavelength 300 nm. The work function of sodium metal



is 2.46 eV.

- (a) Find the maximum K.E. of the ejected electron.  
(b) Determine the cut off wavelength for sodium.

**Solution:**

$$\lambda = 300 \text{ nm}, \quad \Phi = 2.46 \text{ eV}$$

(a) Energy of incident photon  $E = hf = \frac{hc}{\lambda}$

or  $E = \frac{6.63 \times 10^{-34} \text{ Js} \times 3 \times 10^8 \text{ ms}^{-1}}{300 \times 10^{-9} \text{ m}} = 6.63 \times 10^{-19} \text{ J}$

$$E = 4.14 \text{ eV}$$

Now  $K.E._{\text{max}} = hf - \Phi = 4.14 \text{ eV} - 2.46 \text{ eV} = 1.68 \text{ eV}$

(b)  $\Phi = 2.46 \text{ eV} = 3.94 \times 10^{-19} \text{ J}$

Using  $\Phi = hf_0 = \frac{hc}{\lambda_0}$

or  $\lambda_0 = \frac{hc}{\Phi} = \frac{6.63 \times 10^{-34} \text{ Js} \times 3 \times 10^8 \text{ ms}^{-1}}{3.94 \times 10^{-19} \text{ J}} = 5.05 \times 10^{-7} \text{ m}$

$$\lambda_0 = 505 \text{ nm}$$

The cut off wavelength is in the green region of the visible spectrum

### Compton Effect

Arthur Holly Compton at Washington University in 1923 studied the scattering of X-rays by loosely bound electrons from a graphite target (Fig.19.9 a). He measured the wavelength of X-rays scattered at an angle  $\theta$  with the original direction. He found that wavelength  $\lambda_s$  of the scattered X-rays is larger than the wavelength  $\lambda_i$  of the incident X-rays. This is known as Compton effect. The increase in wavelength of scattered X-rays could not be explained on the basis of classical wave theory. Compton suggested that X-rays consist of photons and in the process of scattering the photons suffer collision with electrons like billiard balls (Fig.19.9 b & c). In this collision, a part of incident photon energy and momentum is transferred to an electron. Applying energy and momentum conservation laws to the process, he derived an expression for the change in wavelength  $\Delta\lambda$  known as Compton shift for scattering angle  $\theta$  as

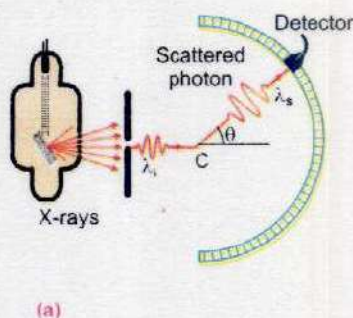
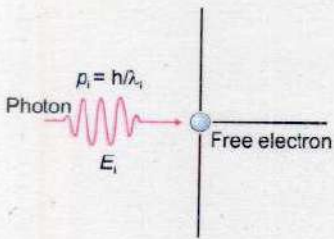
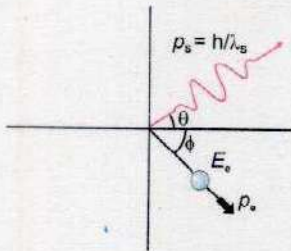


Fig.19.9 (a) Compton's scattering experiment





(b)



(c)

Fig.19.9 (b) A photon collides with an electron and (c) Both are scattered

$$\Delta\lambda = \frac{h}{m_0c} (1 - \cos\theta) \dots\dots\dots (19.15)$$

where  $m_0$  is the rest mass of the electron. The factor  $\frac{h}{m_0c}$  has dimensions of length and is called Compton wavelength and has the numerical value

$$\frac{h}{m_0c} = \frac{6.63 \times 10^{-34} \text{ Js}}{9.1 \times 10^{-31} \text{ kg} \times 3 \times 10^8 \text{ ms}^{-1}} = 2.43 \times 10^{-12} \text{ m}$$

If the scattered X-ray photons are observed at  $\theta = 90^\circ$ , the Compton shift  $\Delta\lambda$  equals the Compton wavelength. The Eq.19.15 was found to be in complete agreement with Compton's experimental result, which again is a striking confirmation of particle like interaction of electromagnetic waves with matter.

Arthur Holly Compton was awarded Nobel Prize in physics in 1927 for his discovery of the effect named after him.

**Example 19.7:** A 50 keV photon is Compton scattered by a quasi-free electron. If the scattered photon comes off at  $45^\circ$ , what is its wavelength?

**Solution:**

$$E = 50 \text{ keV} = 50 \times 10^3 \times 1.6 \times 10^{-19} \text{ J}$$

Using  $E = hf = \frac{hc}{\lambda}$  or  $\lambda = \frac{hc}{E}$

$$\lambda = \frac{6.63 \times 10^{-34} \text{ Js} \times 3 \times 10^8 \text{ ms}^{-1}}{50 \times 10^3 \times 1.6 \times 10^{-19} \text{ J}} = 0.0248 \text{ nm}$$

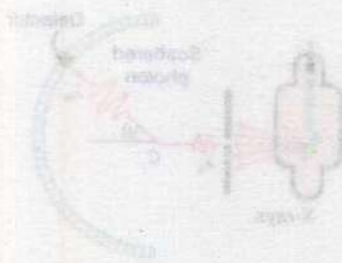
Now  $\lambda' - \lambda = \frac{h}{mc} (1 - \cos 45^\circ)$

$$\begin{aligned} \lambda' - \lambda &= \frac{6.63 \times 10^{-34} \text{ Js}}{9.1 \times 10^{-31} \text{ kg} \times 3 \times 10^8 \text{ ms}^{-1}} (1 - 0.707) \\ &= 0.2429 \times 10^{-11} \text{ m} \times 0.293 \end{aligned}$$

$$\lambda' - \lambda = 0.0007 \text{ nm}$$

$$\lambda' = \lambda + 0.0007 \text{ nm}$$

$$\lambda' = 0.0248 \text{ nm} + 0.0007 \text{ nm} = 0.0255 \text{ nm}$$





## Pair Production

In the previous sections you have studied that a low energy photon interacting with a metal is usually completely absorbed with the emission of electron (Photoelectric effect) and a high energy photon such as that of X-rays is scattered by an atomic electron transferring a part of its energy to the electron (Compton effect). A third kind of interaction of very high energy photon such as that of  $\gamma$ -rays with matter is pair production in which photon energy is changed into an electron-positron pair. A positron is a particle having mass and charge equal to that of electron but the charge being of opposite nature i.e. positive. The creation of two particles with equal and opposite charges is essential for charge conservation in the universe. The positron is also known as antiparticle of electron or anti-electron. The interaction usually takes place in the electric field in the vicinity of a heavy nucleus as shown in the Fig. 19.10 so that there is a particle to take up recoil energy and momentum is conserved.

In the process, radiant energy is converted into matter in accordance with Einstein's equation  $E = mc^2$ , and hence, is also known as materialization of energy. For an electron or positron, the rest mass energy  $= m_0c^2 = 0.51$  MeV. Thus to create the two particles  $2 \times 0.51$  MeV or 1.02 MeV energy is required. For photons of energy greater than 1.02 MeV, the probability of pair production occurrence increases as the energy increases and the surplus energy is carried off by the two particles in the form of kinetic energy. The process can be represented by the equation

$$\text{Energy of photon} = \left[ \begin{array}{l} \text{Energy required} \\ \text{for pair production} \end{array} \right] + \left[ \begin{array}{l} \text{Kinetic energy} \\ \text{of the particles} \end{array} \right]$$

$$hf = 2m_0c^2 + \text{K.E.}(e^-) + \text{K.E.}(e^+) \dots\dots\dots (19.16)$$

## 19.6 ANNIHILATION OF MATTER

It is converse of pair production when a positron comes close to an electron they annihilate or destroy each other. The matter of two particles changes into electromagnetic energy producing two photons in the  $\gamma$ -rays range.



The two photons are produced travelling in opposite directions (Fig. 19.11) so that momentum is conserved. Each

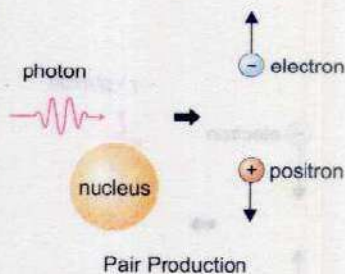


Fig. 19.10



photon has energy 0.51 MeV equivalent to rest mass energy of a particle.

The existence of positron was predicted by Dirac in 1928 and it was discovered in the cosmic radiation in 1932 by Carl Anderson. It gradually became clear that every particle has a corresponding antiparticle with the same mass and charge (if it is a charged particle) but of opposite sign. Particles and antiparticles also differ in the signs of other quantum numbers that we have not yet discussed. A particle and its antiparticle cannot exist together at one place. Whenever they meet, they annihilate each other. That is, the particles disappear, their combined rest energies appear in other forms. Proton and antiproton annihilation has also been observed at Lawrence Berkeley Laboratory.

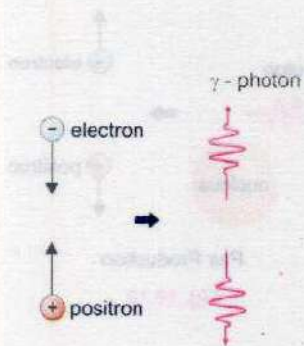


Fig. 19.11

## 19.7 WAVE NATURE OF PARTICLES

It has been observed that light displays a dual nature, it acts as a wave and it acts as a particle. Assuming symmetry in nature, the French physicist, Louis de Broglie proposed in 1924 that particles should also possess wavelike properties. As momentum  $p$  of photon is given by equation 19.11,

$$p = \frac{h}{\lambda}$$

de Broglie suggested that momentum of a material particle of mass  $m$  moving with velocity  $v$  should be given by the same expression. Thus

$$p = \frac{h}{\lambda} = mv$$

or 
$$\lambda = \frac{h}{p} = \frac{h}{mv} \dots\dots\dots (19.17)$$

where  $\lambda$  is the wavelength associated with particle waves. Hence an electron can be considered to be a particle and it can also be considered to be a wave. The equation 19.17 is called de Broglie relation.

An object of large mass and ordinary speed has such a small wavelength that its wave effects such as interference and diffraction are negligible. For example, a rifle bullet of mass 20 g and flying with speed  $330 \text{ ms}^{-1}$  will have a wavelength  $\lambda$  given by

$$\lambda = \frac{h}{mv} = \frac{6.63 \times 10^{-34} \text{ Js}}{2 \times 10^{-2} \text{ kg} \times 330 \text{ ms}^{-1}} = 1 \times 10^{-34} \text{ m}$$

### Do You Know?

Light is, in short, the most refined form of matter (Louis de Broglie 1892-1987).



This wavelength is so small that it is not measurable or detectable by any of its effects.

On the other hand for an electron moving with a speed of  $1 \times 10^6 \text{ ms}^{-1}$ ,

$$\lambda = \frac{6.63 \times 10^{-34} \text{ Js}}{9.1 \times 10^{-31} \text{ kg} \times 1 \times 10^6 \text{ ms}^{-1}} = 7 \times 10^{-10} \text{ m}$$

This wavelength is in the X-rays range. Thus, diffraction effects for electrons are measurable whereas diffraction or interference effects for bullets are not.

### Davisson and Germer Experiment

A convincing evidence of the wave nature of electrons was provided by Clinton J. Davisson and Laster H. Germer. They showed that electrons are diffracted from metal crystals in exactly the same manner as X-rays or any other wave. The apparatus used by them is shown in Fig. 19.12, in which electrons from heated filament are accelerated by an adjustable applied voltage  $V$ . The electron beam of energy  $Ve$  is made incident on a nickel crystal. The beam diffracted from crystal surface enters a detector and is recorded as a current  $I$ . The gain in  $K.E.$  of the electron as it is accelerated by a potential  $V$  in the electron gun is

given by 
$$\frac{1}{2}mv^2 = Ve$$

or 
$$mv^2 = 2Ve \quad ; \quad m^2v^2 = 2mVe$$

or 
$$mv = \sqrt{2mVe}$$

From de Broglie equation

$$\lambda = \frac{h}{mv}$$

Thus 
$$\lambda = \frac{h}{\sqrt{2mVe}} \dots\dots\dots (19.18)$$

In one of the experiments, the accelerating voltage  $V$  was 54 volts, hence

$$\lambda = \frac{h}{\sqrt{2mVe}} = \frac{6.63 \times 10^{-34} \text{ Js}}{\sqrt{2 \times 9.1 \times 10^{-31} \text{ kg} \times 54 \text{ JC}^{-1} \times 1.6 \times 10^{-19} \text{ C}}}$$

$$\lambda = 1.66 \times 10^{-10} \text{ m}$$

This beam of electrons diffracted from crystal surface was obtained for a glancing angle of  $65^\circ$ . According to Bragg's

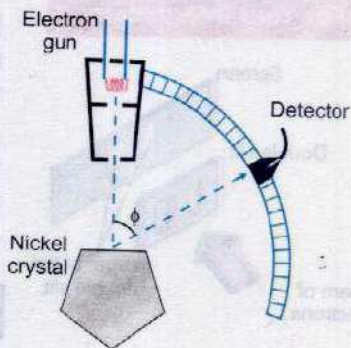


Fig.19.12 Experimental arrangement of Davisson and Germer for electron diffraction.



equation

$$2d \sin \theta = m\lambda$$

For 1st order diffraction  $m = 1$

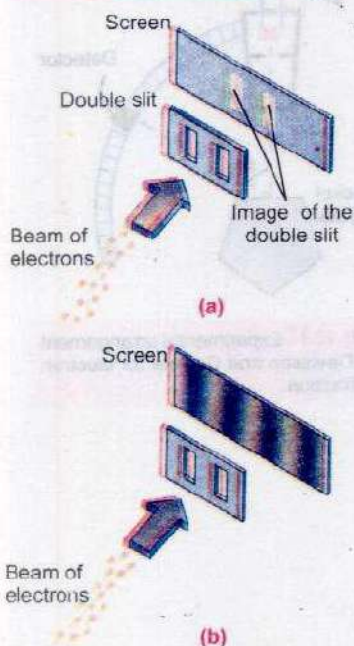
For nickel  $d = 0.91 \times 10^{-10} \text{ m}$

Thus  $2 \times 0.91 \times 10^{-10} \text{ m} \times \sin 65^\circ = \lambda$

which gives  $\lambda = 1.65 \times 10^{-10} \text{ m}$

Thus, experimentally observed wavelength is in excellent agreement with theoretically predicted wavelength.

### For Your Information



(a) If electrons behaved as discrete particles with no wave properties, they would pass through one or the other of the two slits and strike the screen, causing it to glow and produce exact images of the slits. (b) In reality the screen reveals a pattern of bright and dark fringes similar to light is used and interference occurs between the light waves coming from each slit.

Diffraction patterns have also been observed with protons, neutrons, hydrogen atoms and helium atoms thereby giving substantial evidence for the wave nature of particles.

For his work on the dual nature of particles, Prince Louis Victor de Broglie received the 1929 Nobel Prize in physics. Clinton Joseph Davisson and George Paget Thomson shared the Nobel Prize in 1937 for their experimental confirmation of the wave nature of particles.

### Wave Particle Duality

Interference and diffraction of light confirm its wave nature, while photoelectric effect proves the particle nature of light. Similarly, the experiments of Davisson and Germer and G. P. Thomson reveal wave like nature of electrons and in the experiment of J. J. Thomson to find  $e/m$  we had to assume particle like nature of the electron. In the same way we are forced to assume both wavelike and particle like properties for all matter: electrons, protons, neutrons, molecules etc. and also light, X-rays,  $\gamma$ -rays etc. have to be included in this. In other words, matter and radiation have a dual 'wave-particle' nature and this new concept is known as wave particle duality. Niels Bohr pointed out in stating his principle of complementarity that both wave and particle aspects are required for the complete description of both radiation and matter. Both aspects are always present and either may be revealed by an experiment. However, both aspects cannot be revealed simultaneously in a single experiment, which aspect is revealed is determined by the nature of the experiment being done. If you put a diffraction grating in the path of a light beam, you reveal it as a wave. If you allow the light beam to hit a metal surface, you need to regard the beam as a stream of particles to explain your observations. There is no simple experiment that you can carry out with the



beam that will require you to interpret it as a wave and as a particle at the same time. Light behaves as a stream of photons when it interacts with matter and behaves as a wave in traveling from a source to the place where it is detected. In effect, all micro-particles (electrons, protons, photons, atoms etc.) propagate as if they were waves and exchange energies as if they were particles - that is the wave particle duality.

**Example 19.8:** A particle of mass 5.0 mg moves with speed of  $8.0 \text{ ms}^{-1}$ . Calculate its de Broglie wavelength.

**Solution:**

$$m = 5.0 \text{ mg} = 5.0 \times 10^{-6} \text{ kg}$$

$$v = 8.0 \text{ ms}^{-1}$$

$$h = 6.63 \times 10^{-34} \text{ Js}$$

$$\text{Using } \lambda = \frac{h}{mv} = \frac{6.63 \times 10^{-34} \text{ Js}}{5.0 \times 10^{-6} \text{ kg} \times 8.0 \text{ ms}^{-1}} = 1.66 \times 10^{-29} \text{ m}$$

**Example 19.9:** An electron is accelerated through a Potential Difference of 50 V. Calculate its de Broglie wavelength.

**Solution:**

$$m = 9.1 \times 10^{-31} \text{ kg}, \quad V_0 = 50 \text{ V},$$

$$\lambda = ?, \quad e = 1.6 \times 10^{-19} \text{ C}$$

$$\frac{1}{2}mv^2 = V_0e$$

$$p = mv = \sqrt{2mV_0e}$$

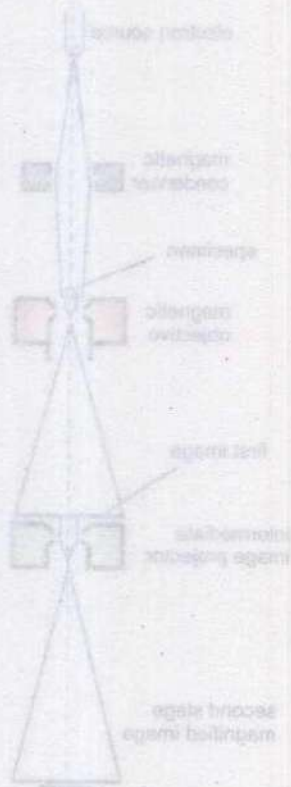
$$\text{then } \lambda = \frac{h}{p} = \frac{h}{\sqrt{2mV_0e}}$$

$$= \frac{6.63 \times 10^{-34} \text{ Js}}{\sqrt{2 \times 9.1 \times 10^{-31} \text{ kg} \times 50 \text{ JC}^{-1} \times 1.6 \times 10^{-19} \text{ C}}}$$

$$\lambda = 1.74 \times 10^{-10} \text{ m}$$

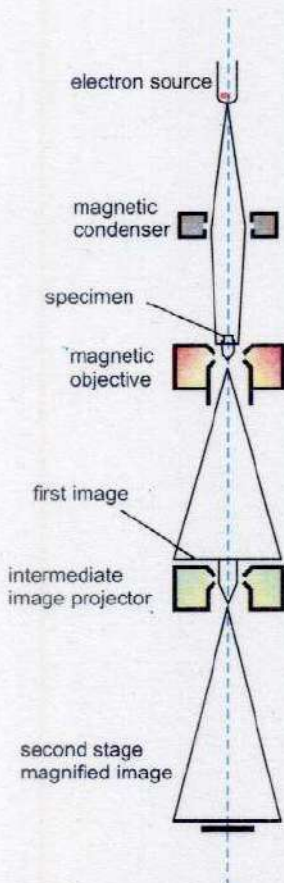
### Uses of Wave Nature of Particles

The fact that energetic particles have extremely short de Broglie wavelengths has been put to practical use in many ultra-modern devices of immense importance such as electron microscope.





## Electron Microscope



Electron microscope (Block Diagram)

Fig. 19.13

### Do You Know?

In the subatomic world few things can be predicted with 100% precision.

Electron microscope makes practical use of the wave nature of electrons which is thousands of times shorter than visible light which enables the electron microscope to distinguish details not visible with optical microscope. In an electron microscope, electric and magnetic fields rather than optical lenses are used to focus electrons by means of electromagnetic forces that are exerted on moving charges. The resulting deflections of the electrons beams are similar to the refraction effects produced by glass lenses used to focus light in optical microscope. The electrons are accelerated to high energies by applying voltage from 30 kV to several megavolts. Such high voltages give extremely short wavelength and also give the electron sufficient energy to penetrate specimen of reasonable thickness. A resolution of 0.5 to 1 nm is possible with a 50 kV microscope as compared to best optical resolution of  $0.2 \mu\text{m}$ . A schematic diagram of the electron microscope is shown in the Figure 19.13. The magnetic conducting lens concentrates the beam from an electron gun on to the specimen. Electrons are scattered out of the beam from the thicker parts of the specimen. The transmitted beam therefore has spatial differences in density that correspond to the features of the specimen. The objective and intermediate lenses produce a real intermediate image and projection lens forms the final image which can be viewed on a fluorescent screen or photographed on special film known as electron micrograph. A three dimensional image of remarkable quality can be achieved by modern versions called scanning electron microscopes.

## 19.8 UNCERTAINTY PRINCIPLE

Position and momentum of a particle cannot both be measured simultaneously with perfect accuracy. There is always a fundamental uncertainty associated with any measurement. This uncertainty is not associated with the measuring instrument. It is a consequence of the wave particle duality of matter and radiation. This was first proposed by Werner Heisenberg in 1927 and hence is known as Heisenberg Uncertainty Principle. This fundamental uncertainty is completely negligible for measurements of position and momentum of macroscopic objects but is a predominant fact of life in the atomic domain. For example, a stream of light photons scattering from a flying tennis ball



hardly affects its path, but one photon striking an electron drastically alters the electron's motion. Since light has also wave properties, we would expect to be able to determine the position of the electron only to within one wavelength of the light being used. Hence, in order to observe the position of an electron with less uncertainty and also for minimizing diffraction effect, we must use light of short wavelength. But it will alter the motion drastically making momentum measurement less precise. If light of wavelength  $\lambda$  is used to locate a micro particle moving along x-axis, the uncertainty in its position measurement is

$$\Delta x \approx \lambda$$

At most, the photon of light can transfer all its momentum

$\left(\frac{h}{\lambda}\right)$  to the micro particle whose own momentum will then be

uncertain by an amount

$$\Delta p \approx \frac{h}{\lambda}$$

Multiplying these two uncertainties gives

$$\Delta x \cdot \Delta p \approx \lambda \left(\frac{h}{\lambda}\right) \approx h \dots\dots\dots (19.19)$$

The equation 19.19 is the mathematical form of uncertainty principle. It states that the product of the uncertainty  $\Delta x$  in the position of a particle at some instant and the uncertainty  $\Delta p$  in the x-component of its momentum at the same instant approximately equals Planck's constant  $h$ .

There is another form of uncertainty principle which relates the energy of a particle and the time at which it had the energy. If the  $\Delta E$  is the uncertainty in our knowledge of the energy of our particle and if the time interval during which

the particle had the energy  $E \pm \frac{\Delta E}{2}$  is  $t_0 \pm \frac{\Delta t}{2}$ , then

$$\Delta E \cdot \Delta t \approx h \dots\dots\dots (19.20)$$

Thus more accurately we determined the energy of a particle, the more uncertain we will be of the time during which it has that energy.

According to Heisenberg's more careful calculations, he found that at the very best

### For Your Information

You can never accurately describe all aspects of a subatomic particle at once.



$$\Delta x \cdot \Delta p \geq \hbar \quad \dots\dots\dots (19.21)$$

and  $\Delta E \cdot \Delta t \geq \hbar \quad \dots\dots\dots (19.22)$

where  $\hbar = \frac{h}{2\pi} = 1.05 \times 10^{-34} \text{ Js}$

Werner Karl Heisenberg received Nobel Prize for physics in 1932 for the development of quantum mechanics.

**Example 19.10:** The life time of an electron in an excited state is about  $10^{-8}$  s. What is its uncertainty in energy during this time?

**Solution:**

Using uncertainty principle

$$\Delta E \cdot \Delta t \approx \hbar$$

$$\Delta E = \frac{\hbar}{\Delta t} = \frac{1.05 \times 10^{-34} \text{ Js}}{10^{-8} \text{ s}}$$

$$\Delta E = 1.05 \times 10^{-26} \text{ J}$$

**Example 19.11:** An electron is to be confined to a box of the size of the nucleus ( $1.0 \times 10^{-14}$  m). What would the speed of the electron be if it were so confined?

**Solution:**

Maximum uncertainty in the location of electron equals the size of the box itself that is  $\Delta x = 1.0 \times 10^{-14}$  m. The minimum uncertainty in the velocity of electron is found from Heisenberg uncertainty principle

$$\Delta p \approx \frac{\hbar}{\Delta x}$$

or  $m\Delta v \approx \frac{\hbar}{\Delta x}$

$$\Delta v = \frac{\hbar}{m\Delta x} = \frac{1.05 \times 10^{-34} \text{ Js}}{9.1 \times 10^{-31} \text{ kg} \times 1.0 \times 10^{-14} \text{ m}} = 1.15 \times 10^{10} \text{ m s}^{-1}$$

For confinement in the box, the speed should be greater than the speed of light. Because this is not possible, we must conclude that an electron can never be found inside the nucleus.



## SUMMARY

- An inertial frame of reference is defined as a coordinate system in which the law of inertia is valid. A frame of reference that is not accelerating is an inertial frame of reference.
- The special theory of relativity treats problems involving inertial or non-accelerating frames of reference. It is based upon two postulates.
  - (i) The laws of physics are the same in all inertial frames.
  - (ii) The speed of light in free space has the same value for all observers, regardless of their state of motion.
- $E = mc^2$  is an important result of special theory of relativity
- A black body is a solid block having a hollow cavity within it. It has small hole and the radiation can enter or escape only through this hole.
- Stephen Boltzmann law states that total energy radiated over all wave length at a particular temperature is directly proportional to the fourth power of that Kelvin temperature.
- The emission of electrons from a metal surface when exposed to ultraviolet light is called photoelectric effect. The emitted electrons are known as photoelectrons.
- When X-rays are scattered by loosely bound electrons from a graphite target, it is known as Compton effect.
- The change of very high energy photon into an electron, positron pair is called pair production.
- When a positron comes close to an electron, they annihilate and produce two photons in the  $\gamma$  - rays range. It is called annihilation of matter.
- Position and momentum of a particle cannot both be measured simultaneously with perfect accuracy. There is always a fundamental uncertainty associated with any measurement. It is a consequence of the wave particle duality of matter and radiation. It is known as Heisenberg uncertainty principle.

## QUESTIONS

- 119.1 What are the measurements on which two observers in relative motion will always agree upon?
- 119.2 Does the dilation means that time really passes more slowly in moving system or that it only seems to pass more slowly?
- 119.3 If you are moving in a spaceship at a very high speed relative to the Earth, would you notice a difference (a) in your pulse rate (b) in the pulse rate of people on Earth?



- 19.4 If the speed of light were infinite, what would the equations of special theory of relativity reduce to?
- 19.5 Since mass is a form of energy, can we conclude that a compressed spring has more mass than the same spring when it is not compressed?
- 19.6 As a solid is heated and begins to glow, why does it first appear red?
- 19.7 What happens to total radiation from a blackbody if its absolute temperature is doubled?
- 19.8 A beam of red light and a beam of blue light have exactly the same energy. Which beam contains the greater number of photons?
- 19.9 Which photon, red, green, or blue carries the most (a) energy and (b) momentum?
- 19.10 Which has the lower energy quanta? Radiowaves or X-rays
- 19.11 Does the brightness of a beam of light primarily depends on the frequency of photons or on the number of photons?
- 19.12 When ultraviolet light falls on certain dyes, visible light is emitted. Why does this not happen when infrared light falls on these dyes?
- 19.13 Will bright light eject more electrons from a metal surface than dimmer light of the same colour?
- 19.14 Will higher frequency light eject greater number of electrons than low frequency light?
- 19.15 When light shines on a surface, is momentum transferred to the metal surface?
- 19.16 Why can red light be used in a photographic dark room when developing films, but a blue or white light cannot?
- 19.17 Photon A has twice the energy of photon B. What is the ratio of the momentum of A to that of B?
- 19.18 Why don't we observe a Compton effect with visible light?
- 19.19 Can pair production take place in vacuum? Explain
- 19.20 Is it possible to create a single electron from energy? Explain.
- 19.21 If electrons behaved only like particles, what pattern would you expect on the screen after the electrons passes through the double slit?
- 19.22 If an electron and a proton have the same de Broglie wavelength, which particle has greater speed?
- 19.23 We do not notice the de Broglie wavelength for a pitched cricket ball. Explain why?
- 19.24 If the following particles have the same energy, which has the shortest wavelength? Electron, alpha particle, neutron, proton.
- 19.25 When does light behave as a wave? When does it behave as a particle?
- 19.26 What advantages an electron microscope has over an optical microscope?
- 19.27 If measurements show a precise position for an electron, can those measurements show precise momentum also? Explain.



## PROBLEMS

- 19.1** A particle called the pion lives on the average only about  $2.6 \times 10^{-8}$  s when at rest in the laboratory. It then changes to another form. How long would such a particle live when shooting through the space at  $0.95 c$ ?  
**[Ans.  $8.3 \times 10^{-8}$  s]**
- 19.2** What is the mass of a 70 kg man in a space rocket traveling at  $0.8 c$  from us as measured from Earth?  
**[Ans. 116.7 kg]**
- 19.3** Find the energy of photon in
- (b) Radiowave of wavelength 100 m
  - (c) Green light of wavelength 550 nm
  - (d) X-ray with wavelength 0.2 nm
- [Ans. (a)  $1.24 \times 10^{-8}$  eV (b) 2.25 eV (c) 6200 eV]**
- 19.4** Yellow light of 577 nm wavelength is incident on a cesium surface. The stopping voltage is found to be 0.25 V. Find
- (a) the Maximum *K.E.* of the photoelectrons
  - (b) the work function of cesium
- [Ans. (a)  $4 \times 10^{-20}$  J (b) 1.91 eV]**
- 19.5** X-rays of wavelength 22 pm are scattered from a carbon target. The scattered radiation being viewed at  $85^\circ$  to the incident beam. What is Compton shift?  
**[Ans.  $2.2 \times 10^{-12}$  m]**
- 19.6** A 90 keV X-ray photon is fired at a carbon target and Compton scattering occurs. Find the wavelength of the incident photon and the wavelength of the scattered photon for scattering angle of (a)  $30^\circ$  (b)  $60^\circ$   
**[Ans. 13.8 pm (a) 14.1 pm (b) 15 pm]**
- 19.7** What is the maximum wavelength of the two photons produced when a positron annihilates an electron? The rest mass energy of each is 0.51 MeV.  
**[Ans.  $2.44 \times 10^{-12}$  m]**
- 19.8** Calculate the wavelength of
- (a) a 140 g ball moving at  $40 \text{ ms}^{-1}$
  - (b) a proton moving at the same speed
  - (c) an electron moving at the same speed
- [Ans. (a)  $1.18 \times 10^{-34}$  m (b) 9.92 nm (c)  $1.82 \times 10^{-5}$  m]**
- 19.9** What is the de Broglie wavelength of an electron whose kinetic energy is 120 eV?  
**[Ans.  $1.12 \times 10^{-10}$  m]**
- 19.10** An electron is placed in a box about the size of an atom that is about  $1.0 \times 10^{-10}$  m. What is the velocity of the electron?  
**[Ans.  $7.29 \times 10^6 \text{ ms}^{-1}$ ]**



# Chapter 20

## ATOMIC SPECTRA

### Learning Objectives

At the end of this chapter the students will be able to:

1. Know experimental facts of hydrogen spectrum.
2. Describe Bohr's postulates of hydrogen atom.
3. Explain hydrogen atom in terms of energy levels.
4. Describe de-Broglie's interpretation of Bohr's orbits.
5. Understand excitation and ionization potentials.
6. Describe uncertainty regarding position of electron in the atom.
7. Understand the production, properties and uses of X-rays.
8. Describe the terms spontaneous emission, stimulated emission, metastable states and population inversion.
9. Understand laser principle.
10. Describe the He-Ne gas laser.
11. Describe the application of laser including holography.

**T**he branch of physics that deals with the investigation of wavelengths and intensities of electromagnetic radiation emitted or absorbed by atoms is called spectroscopy. It includes the study of spectra produced by atoms. In general there are three types of spectra called (i) continuous spectra, (ii) band spectra, and (iii) discrete or line spectra.

Black body radiation spectrum, as described in chapter 19 is an example of continuous spectra; molecular spectra are the examples of band spectra while the atomic spectra, which we shall investigate in detail in this chapter, are examples of discrete or line spectra.

### 20.1 ATOMIC SPECTRA

When an atomic gas or vapour at much less than atmospheric pressure is suitably excited, usually by passing an electric current through it, the emitted radiation has a spectrum, which contains certain specific wavelengths only. An idealized arrangement for observing such atomic spectra is shown in Fig. 20.1. Actual spectrometer uses diffraction grating for better results.

The impression on the screen is in the form of lines if the slit in front of the source S is narrow rectangle. It is for this reason that the spectrum is referred to as line spectrum.

The fact that the spectrum of any element contains wavelengths that exhibit definite regularities was utilized in the second half of the 19<sup>th</sup> century in identifying different elements.



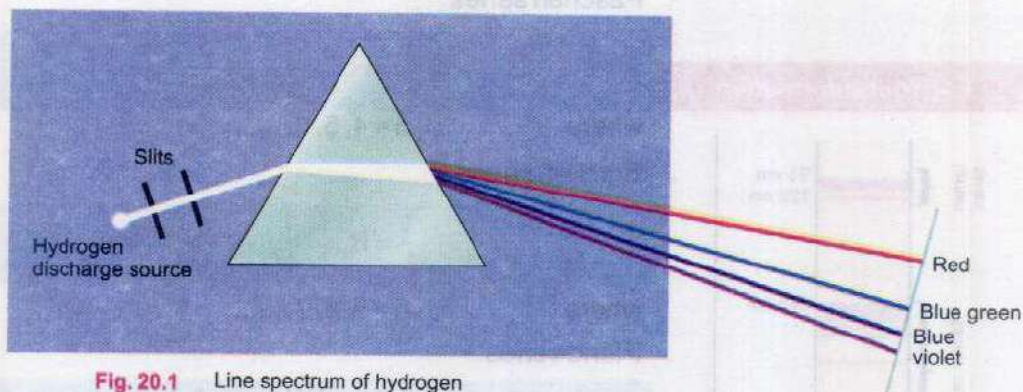


Fig. 20.1 Line spectrum of hydrogen

These regularities were classified into certain groups called the spectral series. The first such series was identified by J.J Balmer in 1885 in the spectrum of hydrogen. This series, called the Balmer series, is shown in Fig.20.2, and is in the visible region of the electromagnetic spectrum.

The results obtained by Balmer were expressed in 1896 by J.R Rydberg in the following mathematical form

$$\frac{1}{\lambda} = R_H \left( \frac{1}{2^2} - \frac{1}{n^2} \right) \dots\dots\dots (20.1)$$

where  $R_H$  is the Rydberg's constant. Its value is  $1.0974 \times 10^7 \text{ m}^{-1}$ . Since then many more series have been discovered and proved helpful in predicting the arrangement of the electrons in different atoms.

### Atomic Spectrum of Hydrogen

The Balmer series contain wavelengths in the visible portion of the hydrogen spectrum. The spectral lines of hydrogen in the ultraviolet and infrared regions fall into several other series. In the ultraviolet region, the Lyman series contains the wavelengths given by the formula

$$\frac{1}{\lambda} = R_H \left( \frac{1}{1^2} - \frac{1}{n^2} \right) \dots\dots\dots (20.2)$$

where  $n = 2, 3, 4, \dots\dots$

In the infrared region, three spectral series have been found whose lines have the wavelengths specified by the formulae:



Fig. 20.2

### For Your Information

#### Different types of spectra



(a) Continuous spectrum



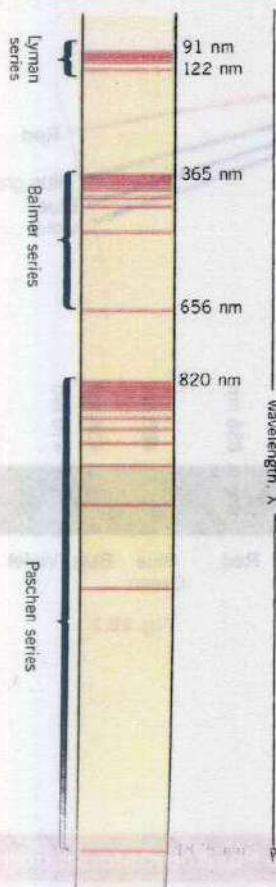
(b) Line spectrum



(c) Band spectrum



**For Your Information**



Line spectrum of atomic hydrogen. Only the Balmer series lies in the visible region of the electromagnetic spectrum.

**Paschen series**

$$\frac{1}{\lambda} = R_H \left( \frac{1}{3^2} - \frac{1}{n^2} \right) \dots\dots\dots (20.3)$$

where  $n = 4, 5, 6, \dots\dots$

**Brackett series**

$$\frac{1}{\lambda} = R_H \left( \frac{1}{4^2} - \frac{1}{n^2} \right) \dots\dots\dots (20.4)$$

where  $n = 5, 6, 7, \dots\dots$

**Pfund series**

$$\frac{1}{\lambda} = R_H \left( \frac{1}{5^2} - \frac{1}{n^2} \right) \dots\dots\dots (20.5)$$

where  $n = 6, 7, 8, \dots\dots$

The existence of these regularities in the hydrogen spectrum together with similar regularities in the spectra of more complex elements, proposes a definite test for any theory of atomic structure.

**20.2 BOHR'S MODEL OF THE HYDROGEN ATOM**

In order to explain the empirical results obtained by Rydberg, Neils Bohr, in 1913, formulated a model of hydrogen atom utilizing classical physics and Planck's quantum theory. This semi classical theory is based on the following three postulates:

**Postulate I:** An electron, bound to the nucleus in an atom, can move around the nucleus in certain circular orbits without radiating. These orbits are called the discrete stationary states of the atom.

**Postulate II:** Only those stationary orbits are allowed for which orbital angular momentum is equal to an integral multiple of  $\frac{h}{2\pi}$  i.e.,

$$mvr = \frac{nh}{2\pi} \dots\dots\dots (20.6)$$

where  $n = 1, 2, 3, \dots\dots$  and  $n$  is called the principal quantum number,  $m$  and  $v$  are the mass and velocity of the orbiting electron respectively, and  $h$  is Planck's constant.



**Postulate III:** Whenever an electron makes a transition, that is, jumps from high energy state  $E_n$  to a lower energy state  $E_p$ , a photon of energy  $hf$  is emitted so that

$$hf = E_n - E_p \quad \dots\dots\dots (20.7)$$

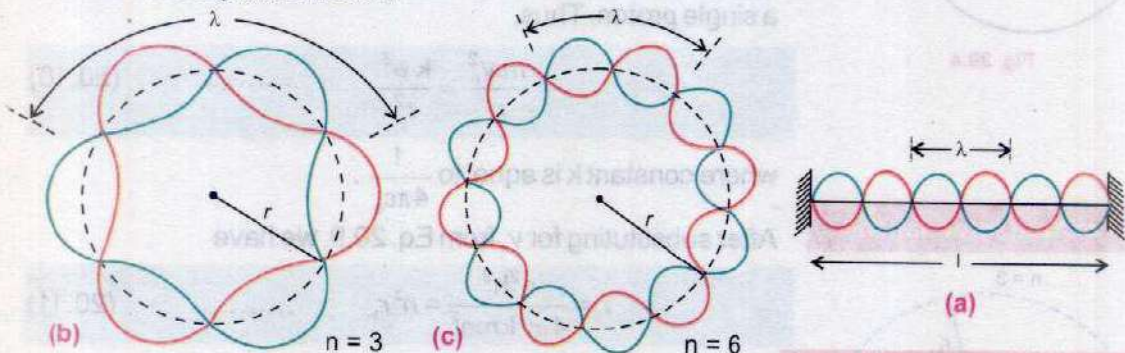
where  $f = c/\lambda$  is the frequency of the radiation emitted.

### de-Broglie's Interpretation of Bohr's Orbits

At the time of formulation of Bohr's theory, there was no justification for the first two postulates, while Postulate III had some roots in Planck's thesis. Later on with the development of de Broglie's hypothesis, some justification could be seen in Postulate II as explained below:

**Do You Know?**

Helium was identified in the Sun using spectroscopy before it was discovered on earth.



**Fig. 20.3** Stationary wave for  $n = 3$  on a string.

**Standing de Broglie waves of electrons around the circumference of Bohr orbits.**

Consider a string of length  $\ell$  as shown in Fig. 20.3 (a). If this is put into stationary vibrations, we must have  $\ell = n\lambda$  where  $n$  is an integer. Suppose that the string is bent into circle of radius  $r$ , as demonstrated for  $n = 3$  and  $n = 6$  in Fig. 20.3 (b) and (c), so that

$$\ell = 2\pi r = n\lambda$$

or 
$$\lambda = \frac{2\pi r}{n} \quad \dots\dots\dots (20.8)$$

From de Broglie's hypothesis

$$\lambda = \frac{h}{p} = \frac{h}{mv}$$

thus 
$$\frac{h}{mv} = \frac{2\pi r}{n}$$

or 
$$mvr = \frac{nh}{2\pi}$$

which is Postulate II.



## Quantized Radii

Consider a hydrogen atom in which electron moving with velocity  $v_n$  is in stationary circular orbit of radius  $r_n$ . From Eq. (20.6),

$$v_n = \frac{nh}{2\pi m r_n} \quad \dots\dots\dots (20.9)$$

For this electron to stay in the circular orbit, shown in Fig. 20.4, the centripetal force  $F_c = \frac{mv_n^2}{r_n}$  is provided by the Coulomb's force  $F_c = \frac{ke^2}{r_n^2}$ , where  $e$  is the magnitude of charge on electron as well as on the hydrogen nucleus consisting of a single proton. Thus,

$$\frac{mv_n^2}{r_n} = \frac{ke^2}{r_n^2} \quad \dots\dots\dots (20.10)$$

where constant  $k$  is equal to  $\frac{1}{4\pi\epsilon_0}$ .

After substituting for  $v_n$  from Eq. 20.9, we have

$$r_n = \frac{n^2 h^2}{4\pi^2 k m e^2} = n^2 r_1 \quad \dots\dots\dots (20.11)$$

where  $r_1 = \frac{h^2}{4\pi^2 k m e^2} = 0.053 \text{ nm}$

This agrees with the experimentally measured values and is called the first Bohr orbit radius of the hydrogen atom. Thus according to Bohr's theory, the radii of different stationary orbits of the electrons in the hydrogen atom are given by

$$r_n = r_1, 4r_1, 9r_1, 16r_1, \dots\dots$$

Substituting the value of  $r_n$  from Eq. 20.11 in Eq. 20.9, the speed of electron in the  $n$ th orbit is

$$v_n = \frac{2\pi ke^2}{nh} \quad \dots\dots\dots (20.12)$$

## Quantized Energies

Let us now calculate the total energy  $E_n$  of the electron in the Bohr orbit;  $E_n$  is the sum of the kinetic energy K.E. and the potential energy  $U$ . i.e.,

$$E_n = \text{K.E.} + U = \frac{1}{2} m v_n^2 + \left( \frac{-ke^2}{r_n} \right) \quad \dots\dots\dots (20.13)$$

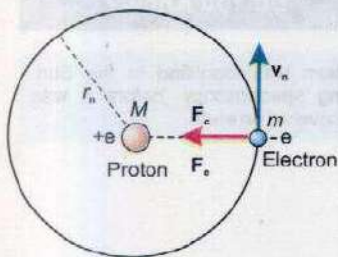
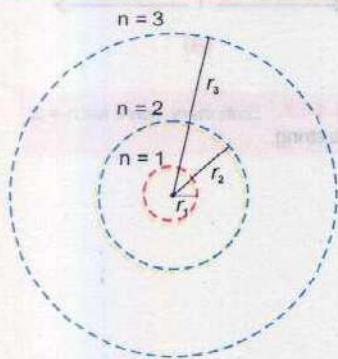


Fig. 20.4

### For Your Information



The first Bohr orbit in the hydrogen atom has a radius  $r_1 = 5.3 \times 10^{-11} \text{ m}$ . The second and third Bohr orbits have radii  $r_2 = 4r_1$  and  $r_3 = 9r_1$ , respectively.



By rearranging Eq. (20.10), we get

$$\frac{1}{2} m v_n^2 = \frac{k e^2}{2 r_n} \quad \dots\dots\dots (20.14)$$

then 
$$E_n = \frac{k e^2}{2 r_n} - \frac{k e^2}{r_n} = -\frac{k e^2}{2 r_n} \quad \dots\dots\dots (20.15)$$

By substituting the value of  $r_n$  from Eq. (20.11), we have

$$E_n = -\frac{1}{n^2} \left( \frac{2\pi^2 k^2 m e^4}{h^2} \right) = -\frac{E_o}{n^2} \quad \dots\dots\dots (20.16)$$

where 
$$E_o = \frac{2\pi^2 k^2 m e^4}{h^2} = \text{constant} = 13.6 \text{ eV}$$

which is the energy required to completely remove an electron from the first Bohr orbit. This is called ionization energy. The ionization energy may be provided to the electron by collision with an external electron. The minimum potential through which this external electron should be accelerated so that it can supply the requisite ionization energy is known as ionization potential. Thus for  $n = 1, 2, 3, \dots\dots$  we get the allowed energy levels of a hydrogen atom to be

$$E_n = -E_o, -\frac{E_o}{4}, -\frac{E_o}{9}, -\frac{E_o}{16}, \dots\dots\dots$$

The experimentally measured value of the binding energy of the electron in the hydrogen atom is in perfect agreement with the value predicted by Bohr theory.

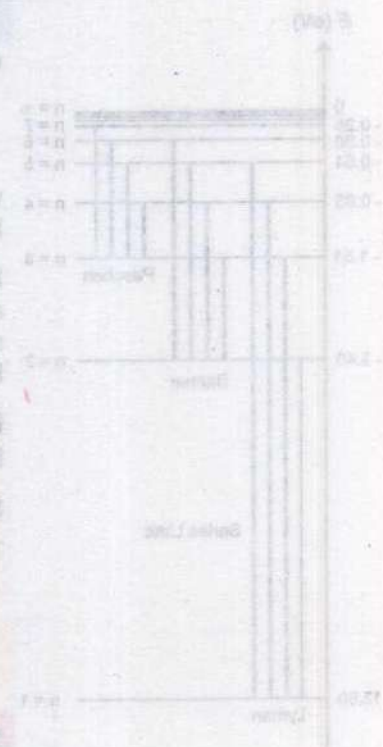
Normally the electron in the hydrogen atom is in the lowest energy state corresponding to  $n = 1$  and this state is called the ground state or normal state. When it is in higher orbit, it is said to be in the excited state. The atom may be excited by collision with externally accelerated electron. The potential through which an electron should be accelerated so that, on collision it can lift the electron in the atom from its ground state to some higher state, is known as excitation potential.

### Hydrogen Emission Spectrum

The results derived above for the energy levels along with Postulate III can be used to arrive at the expression for the wavelength of the hydrogen spectrum. Suppose that the electron in the hydrogen atom is in the excited state  $n$  with

### Do You Know?

The orbital electrons have specific amount of energies where as free electrons may have any amount of energy.





### Do You Know?

Photon must have energy exactly equal to the energy difference between the two shells for excitation of an atom but an electron with K.E greater than the required difference can excite the gas atoms.

energy  $E_n$  and makes a transition to a lower state  $p$  with energy  $E_p$ , where  $E_p < E_n$ , then

$$hf = E_n - E_p$$

where  $E_n = -\frac{E_0}{n^2}$  and  $E_p = -\frac{E_0}{p^2}$

hence  $hf = -E_0 \left( \frac{1}{n^2} - \frac{1}{p^2} \right)$

Substituting for  $f = c/\lambda$  and rearranging

$$\frac{1}{\lambda} = \frac{E_0}{hc} \left( \frac{1}{p^2} - \frac{1}{n^2} \right)$$

or  $\frac{1}{\lambda} = R_H \left( \frac{1}{p^2} - \frac{1}{n^2} \right) \dots \dots \dots (20.17)$

where  $R_H$  is the Rydberg constant given by the equation

$$R_H = \frac{E_0}{hc} = 1.0974 \times 10^7 \text{ m}^{-1} \dots \dots \dots (20.18)$$

which agrees well with the latest measured value for hydrogen atom.

Eq. 20.17 reduces to the empirical result derived by Rydberg and given by Eq 20.1, provided that we substitute  $p = 2$  and  $n = 3, 4, 5, \dots$ . The different energy levels corresponding to Eq. 20.17 are shown in Fig. 20.5.

**Example 20.1:** Find the speed of the electron in the first Bohr orbit.

**Solution:**

The speed found from Eq. (20.12) with  $n = 1$ , is

$$v_1 = \frac{2\pi ke^2}{h} = 2 \times 3.14 \times (9 \times 10^9 \text{ Nm}^2\text{C}^{-2}) \left( \frac{(1.6 \times 10^{-19} \text{ C})^2}{6.63 \times 10^{-34} \text{ Js}} \right)$$

$$v_1 = 2.19 \times 10^6 \text{ ms}^{-1}$$

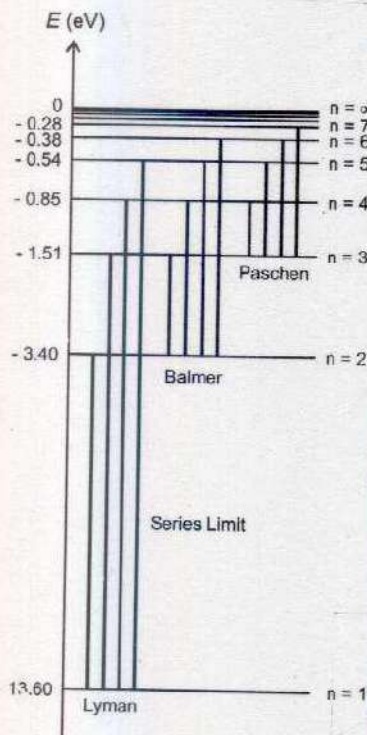


Fig. 20.5 Energy level diagram for the hydrogen atom.

## 20.3 INNER SHELL TRANSITIONS AND CHARACTERISTIC X-RAYS

The transitions of electrons in the hydrogen or other light elements result in the emission of spectral lines in the infrared, visible or ultraviolet region of electromagnetic spectrum due to small energy differences in the transition levels.



In heavy atoms, the electrons are assumed to be arranged in concentric shells labeled as K, L, M, N, O etc., the K shell being closest to the nucleus, the L shell next, and so on (Fig. 20.6). The inner shell electrons are tightly bound and large amount of energy is required for their displacement from their normal energy levels. After excitation, when an atom returns to its normal state, photons of larger energy are emitted. Thus transition of inner shell electrons in heavy atoms gives rise to the emission of high energy photons or X-rays. These X-rays consist of series of specific wavelengths or frequencies and hence are called characteristic X-rays. The study of characteristic X-rays spectra has played a very important role in the study of atomic structure and the periodic table of elements.

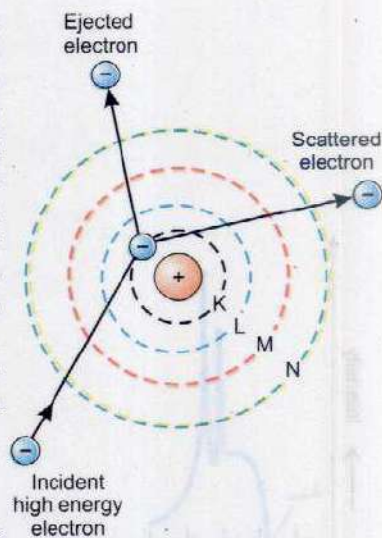


Fig. 20.6

### Production of X-rays

Fig. 20.7 shows an arrangement of producing X-rays. It consists of a high vacuum tube called X-ray tube. When the cathode is heated by the filament F, it emits electrons which are accelerated towards the anode T. If  $V$  is the

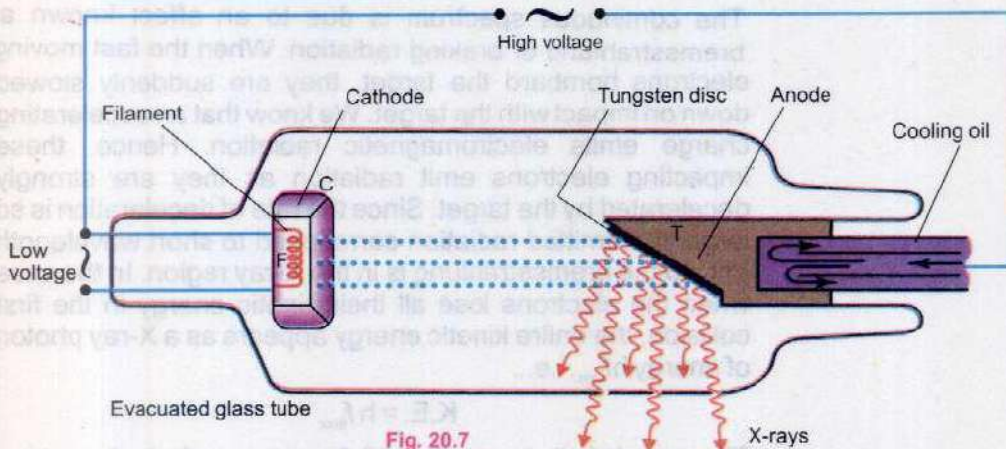


Fig. 20.7

potential difference between C and T, the kinetic energy K.E. with which the electron strike the target is given by

$$K.E. = Ve \quad \dots\dots\dots (20.19)$$

Suppose that these fast moving electrons of energy  $Ve$  strike a target made of tungsten or any other heavy element. It is possible that in collision, the electrons in the innermost shells, such as K or L, will be knocked out. Suppose that one of the electrons in the K shell is removed, thereby producing a vacancy or hole in that shell. The electron from the L shell



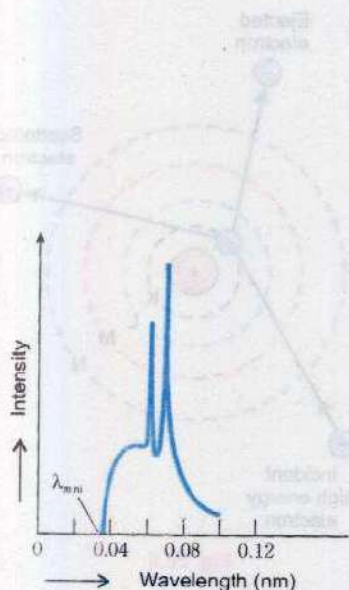


Fig. 20.8

jumps to occupy the hole in the K shell, thereby emitting a photon of energy  $hf_{K\alpha}$  called the  $K_{\alpha}$  X-ray given by

$$hf_{K\alpha} = E_L - E_K \quad \dots\dots\dots (20.20)$$

It is also possible that the electron from the M shell might also jump to occupy the hole in the K shell. The photons emitted are  $K_{\beta}$  X-ray with energies

$$hf_{K\beta} = E_M - E_K \quad \dots\dots\dots (20.21)$$

these photons give rise to  $K_{\beta}$  X-ray and so on.

The photons emitted in such transitions i.e., inner shell transitions are called characteristic X-rays, because their energies depend upon the type of target material.

The holes created in the L and M shells are occupied by transitions of electrons from higher states creating more X-rays. The characteristic X-rays appear as discrete lines on a continuous spectrum as shown in Fig. 20.8.

### The Continuous X-ray Spectrum

The continuous spectrum is due to an effect known as bremsstrahlung or braking radiation. When the fast moving electrons bombard the target, they are suddenly slowed down on impact with the target. We know that an accelerating charge emits electromagnetic radiation. Hence, these impacting electrons emit radiation as they are strongly decelerated by the target. Since the rate of deceleration is so large, the emitted radiation correspond to short wavelength and so the bremsstrahlung is in the X-ray region. In the case when the electrons lose all their kinetic energy in the first collision, the entire kinetic energy appears as a X-ray photon of energy  $hf_{\max}$ , i.e.,

$$\text{K.E.} = hf_{\max}$$

The wavelength  $\lambda_{\min}$  in Fig. 20.8 corresponds to frequency  $f_{\max}$ . Other electrons do not lose all their energy in the first collision. They may suffer a number of collisions before coming to rest. This will give rise to photons of smaller energy or X-rays of longer wavelength. Thus the continuous spectrum is obtained due to deceleration of impacting electrons.

### Properties and Uses of X-rays

X-rays have many practical applications in medicine and industry. Because X-rays can penetrate several centimetres



into a solid matter, so they can be used to visualize the interiors of the materials opaque to ordinary light, such as fractured bones or defects in structural steel. The object to be visualized is placed between an X-ray source and a large sheet of photographic film; the darkening of the film is proportional to the radiation exposure. A crack or air bubble allows greater amount of X-rays to pass. This appears as a dark area on the photographic film. Shadow of bones appears lighter than the surrounding flesh. It is due to the fact that bones contain greater proportions of elements with high atomic number and so they absorb greater amount of incident X-rays than flesh. In flesh, light elements like carbon, hydrogen and oxygen predominate. These elements allow greater amount of incident X-rays to pass through them.

### CAT - Scanner

In the recent past, several vastly improved X-ray techniques have been developed. One widely used system is computerized axial tomography; the corresponding instrument is called CAT-Scanner. The X-ray source produces a thin fan-shaped beam that is detected on the opposite side of the subject by an array of several hundred detectors in a line. Each detector measures absorption of X-ray along a thin line through the subject. The entire apparatus is rotated around the subject in the plane of the beam during a few seconds. The changing reactions of the detector are recorded digitally; a computer processes this information and reconstructs a picture of different densities over an entire cross section of the subject. Density differences of the order of one percent can be detected with CAT-Scans. Tumors, and other anomalies much too small to be seen with older techniques can be detected.

### Biological Effects of X-rays

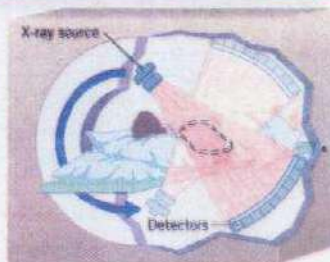
X-rays cause damage to living tissue. As X-ray photons are absorbed in tissues, they break molecular bonds and create highly reactive free radicals (such as  $\cdot H$  and  $\cdot OH$ ), which in turn can disturb the molecular structure of the proteins and especially the genetic material. Young and rapidly growing cells are particularly susceptible; hence X-rays are useful for selective destruction of cancer cells. On the other hand a cell may be damaged by radiation but survive, continue dividing and produce generation of defective cells. Thus X-rays can cause cancer. Even when the organism itself shows no apparent damage, excessive

### For Your Information



An X-ray picture of a hand.

### Interesting Information



In CAT scanning a "fanned-out" array of X-ray beams is directed through the patient from a number of different orientations.



### Do You Know?



(a)



(b)

(a) This two-dimensional CAT scan of a brain reveals a large intracranial tumor (colored purple). (b) Three-dimensional CAT scans are now available and this example reveals an arachnoid cyst (colored yellow) within a skull. In both photographs the colors are artificial having been computer generated to aid in distinguishing anatomical features.

radiation exposure can cause changes in their productivity system that will affect the organism's offspring.

## 20.4 UNCERTAINTY WITHIN THE ATOM

One of the characteristics of dual nature of matter is fundamental limitation in the accuracy of the simultaneous measurement of the position and momentum of a particle.

Heisenberg showed that this is given by the equation

$$\Delta p \Delta x \geq \frac{h}{2\pi}$$

However, these limitations are significant in the realm of atom. One interesting question is whether electrons are present in atomic nuclei. As the typical nuclei are less than  $10^{-14}$  m in diameter, for an electron to be confined within such a nucleus, the uncertainty in its position is of the order of  $10^{-14}$  m. The corresponding uncertainty in the electron's momentum

$$\Delta p \geq \frac{h}{\Delta x}$$

$$\geq \frac{6.63 \times 10^{-34} \text{ Js}}{10^{-14} \text{ m}} = 6.63 \times 10^{-20} \text{ kg ms}^{-1}$$

As

$$\Delta p = m \Delta v$$

Hence 
$$\Delta v = \frac{6.63 \times 10^{-20} \text{ kg ms}^{-1}}{9.11 \times 10^{-31} \text{ kg}} \geq 7.3 \times 10^{10} \text{ ms}^{-1}$$

Hence, for the electron to be confined to a nucleus, its speed would have to be greater than  $10^{10} \text{ ms}^{-1}$  i.e., greater than the speed of light. Because this is impossible, we must conclude that an electron can never be found inside of a nucleus. Can an electron reside inside the atom? To find this, we again calculate the speed of an electron and if it turns out to be less than the speed of light, we have reasonable expectation of finding the electron within the atom but outside the nucleus. The radius of the hydrogen atom is about  $5 \times 10^{-11}$  m. Applying the uncertainty principle to the momentum of electron in the atom we have

$$\Delta p \geq \frac{h}{\Delta x}$$

As

$$\Delta p = m \Delta v$$

Therefore,

$$\Delta v = \frac{h}{m \Delta x}$$



or an atom  $\Delta x$  is given as  $5 \times 10^{-11} \text{ m}$

thus 
$$\Delta v = \frac{6.63 \times 10^{-34} \text{ Js}}{9.11 \times 10^{-31} \text{ kg} \times 5 \times 10^{-11} \text{ m}}$$

$$= 1.46 \times 10^7 \text{ ms}^{-1}$$

his speed of the electron is less than the speed of light, therefore, it can exist in the atom but outside the nucleus.

## 0.5 LASER

aser is the acronym for Light Amplification by Stimulated Emission of Radiation. As the name indicates, lasers are used for producing an intense, monochromatic, and unidirectional coherent beam of visible light. To understand the working of a laser, terms such as stimulated emission and population inversion must be understood.

### Spontaneous and Stimulated Emissions

Consider a sample of free atoms some of which are in the ground state with energy  $E_1$  and some in the excited state  $E_2$  as shown in Fig. 20.9. The photons of energy  $hf = E_2 - E_1$  are incident on this sample. These incident photons can interact with atoms in two different ways. In Fig. 20.9 (a) the incident photon is absorbed by an atom in the ground state  $E_1$ , thereby raising the atom in the excited state  $E_2$ . This process is called stimulated or induced absorption. Once in the excited state, two things can happen to the atom. (i) It may decay by spontaneous emission as shown in Fig. 20.9 (b), in which the atom emits a photon of energy  $hf = E_2 - E_1$ , in any arbitrary direction.

The other alternative for the atom in the excited state  $E_2$  is to decay by stimulated or induced emission as shown in Fig. 20.9 (c). In this case the incident photon of energy  $hf = E_2 - E_1$  induces the atom to decay by emitting a photon that travels in the direction of the incident photon. For each incident photon we will have two photons going in the same direction thus we have accomplished two things; an amplified as well as a unidirectional coherent beam. From a practical point this is possible only if there is more stimulated or induced emission than spontaneous emission. This can be achieved as described in the next section.

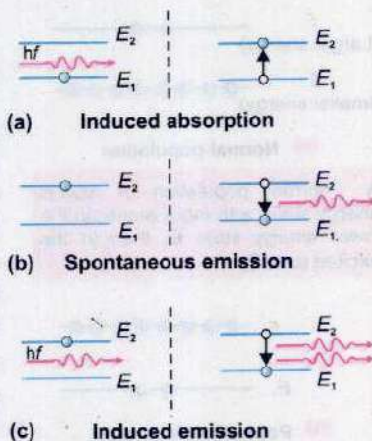


Fig 20.9



## Population Inversion and Laser Action

Let us consider a simple case of a material whose atoms can reside in three different states as shown in Fig. 20.10, state

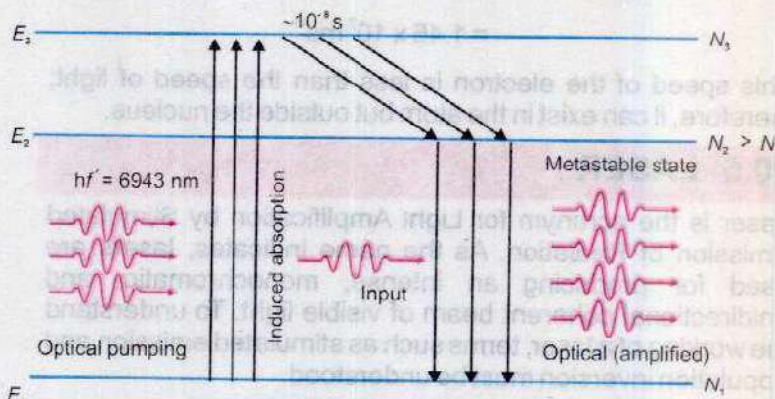
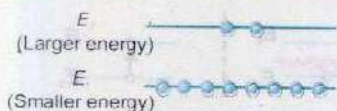


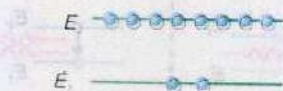
Fig. 20.10

### For Your Information



(a) Normal population

A normal population of atomic energy state, with more atomic in the lower energy state  $E_1$  than in the excited state  $E_2$ .



(b) Population inversion

A population inversion, in which the higher energy state has a greater population than the lower energy state.

$E_1$ , which is ground state; the excited state  $E_3$ , in which the atoms can reside only for  $10^{-8}$  s and the metastable state  $E_2$  in which the atoms can reside for  $\sim 10^{-1}$  s, much longer than  $10^{-8}$  s. A metastable state is an excited state in which an excited electron is unusually stable and from which the electron spontaneously falls to lower state only after relatively longer time. The transition from or to this state are difficult as compared to other excited states. Hence, instead of direct excitation to this state, the electrons are excited to higher level for spontaneous fall to metastable state. Also let us assume that the incident photons of energy  $hf = E_3 - E_1$  raise the atom from the ground state  $E_1$  to the excited state  $E_3$  but the excited atoms do not decay back to  $E_1$ . Thus the only alternative for the atoms in the excited state  $E_3$  is to decay spontaneously to state  $E_2$ , the atoms reach state  $E_2$  much faster than they leave state  $E_2$ . This eventually leads to the situation that the state  $E_2$  contains more atoms than state  $E_1$ . This situation is known as population inversion.

Once the population inversion has been reached, the lasing action of a laser is simple to achieve. The atoms in the metastable state  $E_2$  are bombarded by photons of energy  $hf = E_2 - E_1$ , resulting in an induced emission, giving an intense, coherent beam in the direction of the incident photon.



The emitted photons must be confined in the assembly long enough to stimulate further emission from other excited atoms. This is achieved by using mirrors at the two ends of the assembly. One end is made totally reflecting, and the other end is partially transparent to allow the laser beam to escape (Fig.20.11). As the photons move back and forth between the reflecting mirrors they continue to stimulate other excited atoms to emit photons. As the process continues the number of photons multiply, and the resulting radiation is, therefore, much more intense and coherent than light from ordinary sources.

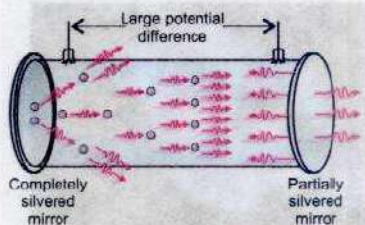


Fig. 20.11

### Helium - Neon Laser

It is a most common type of lasers used in physics laboratories. Its discharge tube is filled with 85% helium and 15% neon gas. The neon is the lasing or active medium in this tube. By chance, helium and neon have nearly identical metastable states, respectively located 20.61 eV and 20.66 eV level. The high voltage electric discharge excites the electrons in some of the helium atoms to the 20.61 eV state. In this laser, population inversion in neon is achieved by direct collisions with same energy electrons of helium atoms. Thus excited helium atoms collide with neon atoms, each transferring its own 20.61 eV of energy to an electron in the neon atom along with 0.05 eV of K.E. from the moving atom. As a result, the electrons in neon atoms are raised to the 20.66 eV state. In this way, a population inversion is sustained in the neon gas relative to an energy level of 18.70 eV. Spontaneous emission from neon atoms initiate laser action and stimulated emission causes electrons in the neon to drop from 20.66 eV to the 18.70 eV level and red laser light of wavelength 632.8 nm corresponding to 1.96 eV energy is generated (Fig. 20.12).

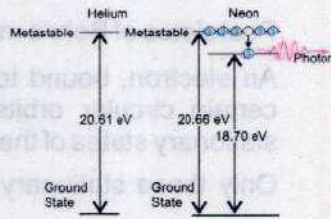


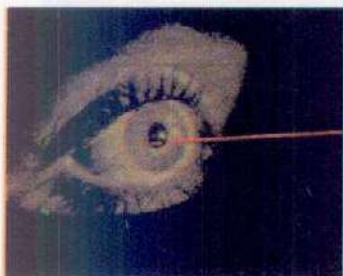
Fig. 20.12

### Uses of Laser in Medicine and Industry

1. Laser beams are used as surgical tool for "welding" detached retinas.
2. The narrow intense beam of laser can be used to destroy tissue in a localized area. Tiny organelles with a living cell have been destroyed by using laser to study how the absence of that organelle affects the behavior of the cell.
3. Finely focused beam of laser has been used to destroy cancerous and pre-cancerous cell.



### Do You Know?



The helium-neon laser beam is being used to diagnose diseases of the eye. The use of laser technology in the field of ophthalmology is widespread.

4. The heat of the laser seals off capillaries and lymph vessels to prevent spread of the disease.
5. The intense heat produced in small area by a laser beam is also used for welding and machining metals and for drilling tiny holes in hard materials.
6. The precise straightness of a laser beam is also useful to surveyors for lining up equipment especially in inaccessible locations.
7. It is potential energy source for inducing fusion reactions.
8. It can be used for telecommunication along optical fibres.
9. Laser beam can be used to generate three-dimensional images of objects in a process called holography.

### SUMMARY

- When an atomic gas or vapours at less than atmospheric pressure is suitably excited, usually by passing electric current through it, the emitted radiation has a spectrum which contains certain specific wavelengths only.
- Postulates of Bohr's model of hydrogen atom are:
  - i. An electron, bound to the nucleus in an atom, can move around the nucleus in certain circular orbits without radiating. These orbits are called the discrete stationary states of the atom.
  - ii. Only those stationary states are allowed for which orbital angular momentum is equal to an integral multiple of  $h$  i.e.,  $mvr = \frac{nh}{2\pi}$
  - iii. Whenever an electron makes a transition, i.e., jumps from high energy state  $E_n$  to a lower energy state  $E_p$ , a photon of energy  $hf$  is emitted so that  $hf = E_n - E_p$ .
- The transition of electrons in the hydrogen or other light elements result in the emission of spectral lines in the infrared, visible or ultraviolet region of electromagnetic spectrum due to small energy differences in the transition levels.
- The X-rays emitted in inner shell transitions are called characteristic X-rays, because their energy depends upon the type of target material.
- The X-rays that are emitted in all directions and with a continuous range of frequencies are known as continuous X-rays.
- Laser is the acronym for Light Amplification by Stimulated Emission of Radiation.



- The incident photon absorbed by an atom in the ground state  $E_1$ , thereby leaving the atom in the excited state  $E_2$  is called stimulated or induced absorption.
- Spontaneous or induced emission is that in which the atom emits a photon of energy  $hf = E_2 - E_1$  in any arbitrary direction.
- Stimulated or induced emission is that in which the incident photon of energy  $hf = E_2 - E_1$  induces the atom to decay by emitting a photon that travels in the direction of the incident photon. For each incident photon, we will have two photons going in the same direction giving rise to an amplified as well as a unidirectional coherent beam.

### QUESTIONS

- 20.1 Bohr's theory of hydrogen atom is based upon several assumptions. Do any of these assumptions contradict classical physics?
- 20.2 What is meant by a line spectrum? Explain, how line spectrum can be used for the identification of elements?
- 20.3 Can the electron in the ground state of hydrogen absorb a photon of energy 13.6 eV and greater than 13.6 eV?
- 20.4 How can the spectrum of hydrogen contain so many lines when hydrogen contains one electron?
- 20.5 Is energy conserved when an atom emits a photon of light?
- 20.6 Explain why a glowing gas gives only certain wavelengths of light and why that gas is capable of absorbing the same wavelengths? Give a reason why it is transparent to other wavelengths?
- 20.7 What do we mean when we say that the atom is excited?
- 20.8 Can X-rays be reflected, refracted, diffracted and polarized just like any other waves? Explain.
- 20.9 What are the advantages of lasers over ordinary light?
- 20.10 Explain why laser action could not occur without population inversion between atomic levels?

### PROBLEMS

- 20.1 A hydrogen atom is in its ground state ( $n = 1$ ). Using Bohr's theory, calculate (a) the radius of the orbit, (b) the linear momentum of the electron, (c) the angular momentum of the electron (d) the kinetic energy, (e) the potential energy, and (f) the total energy.

[Ans: (a)  $0.529 \times 10^{-10} \text{ m}$  (b)  $1.99 \times 10^{-24} \text{ kg ms}^{-1}$  (c)  $1.05 \times 10^{-34} \text{ kg m}^2\text{s}^{-1}$   
(d) 13.6 eV (e) - 27.2 eV (f) -13.6 eV]



- 20.2 What are the energies in eV of quanta of wavelength?  $\lambda = 400, 500$  and  $700$  nm. (Ans: 3.10 eV, 2.49 eV, 1.77 eV)
- 20.3 An electron jumps from a level  $E_i = -3.5 \times 10^{-19}$  J to  $E_f = -1.20 \times 10^{-18}$  J. What is the wavelength of the emitted light? (Ans: 234 nm)
- 20.4 Find the wavelength of the spectral line corresponding to the transition in hydrogen from  $n = 6$  state to  $n = 3$  state? (Ans: 1094 nm)
- 20.5 Compute the shortest wavelength radiation in the Balmer series? What value of  $n$  must be used? (Ans: 364.5 nm,  $n = \infty$ )
- 20.6 Calculate the longest wavelength of radiation for the Paschen series. (Ans: 1875 nm)
- 20.7 Electrons in an X-ray tube are accelerated through a potential difference of 3000 V. If these electrons were slowed down in a target, what will be the minimum wavelength of X-rays produced? (Ans:  $4.14 \times 10^{-10}$  m)
- 20.8 The wavelength of K X-ray from copper is  $1.377 \times 10^{-10}$  m. What is the energy difference between the two levels from which this transition results? (Ans: 9.03 keV)
- 20.9 A tungsten target is struck by electrons that have been accelerated from rest through 40 kV potential difference. Find the shortest wavelength of the bremsstrahlung radiation emitted. (Ans:  $0.31 \times 10^{-10}$  m)
- 20.10 The orbital electron of a hydrogen atom moves with a speed of  $5.456 \times 10^5$  ms<sup>-1</sup>.  
 (a) Find the value of the quantum number  $n$  associated with this electron.  
 (b) Calculate the radius of this orbit.  
 (c) Find the energy of the electron in this orbit.  
 (Ans:  $n = 4, r_4 = 0.846$  nm;  $E_4 = -0.85$  eV)



# Chapter 21

## NUCLEAR PHYSICS

### Learning Objectives

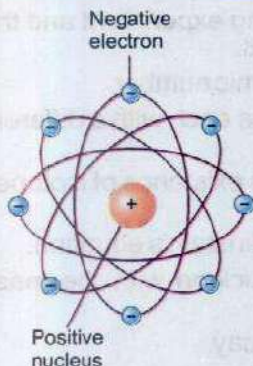
At the end of this chapter the students will be able to:

1. Understand the qualitative treatment of Rutherford's scattering experiment and the evidence it provides for the existence and small size of nucleus.
2. Distinguish between nucleon number (mass number) and atomic number.
3. Understand that an element can exist in various isotopic forms each with a different number of neutrons.
4. Understand the use of mass spectrograph to demonstrate the existence of isotopes and to measure their relative abundance.
5. Understand mass defect and calculate binding energy using Einstein's equation.
6. Illustrate graphically the variation of binding energy per nucleon with the mass number.
7. Appreciate the spontaneous and random nature of nuclear decay.
8. Explain the meaning of half-life.
9. Recognize and use decay law.
10. Understand and describe the interaction of nuclear radiation with matter.
11. Understand the use of Wilson cloud chamber, Geiger Muller counter and solid state detectors to detect the radiations.
12. Appreciate that atomic number and mass number conserve in nuclear process.
13. Describe energy and mass conservation in simple reactions and in radioactive decay.
14. Understand and describe the phenomena of nuclear fission and nuclear fusion.
15. Explain the working principle of nuclear reactor.
16. Be aware of various types of nuclear reactors.
17. Show an awareness about nuclear radiation exposure and biological effects of radiation.
18. Describe in simple terms the use of radiations for medical diagnosis and therapy.
19. Understand qualitatively the importance of limiting exposure to ionizing radiation.
20. Outline the use of tracer technique to obtain diagnostic information about internal structures.
21. Describe examples of the use of radioactive tracers in diagnosis.
22. Describe basic forces of nature.
23. Describe the modern view of the building blocks of matter based on hadrons, leptons and quarks.



Soon after the discovery of electron and proton in an atom, the quest started to find the way in which these charged particles are present in an atom. From his experiments Ernest Rutherford developed a nuclear model of the atom. His model of the atom consisted of a small dense, positively charged nucleus with negative electrons orbiting about it. In 1920 Rutherford suggested that there is probably another particle within the nucleus, neutral one, to which he gave the name neutron. James Chadwick discovered neutron in 1932.

### Do You Know?



From  $\alpha$ -particles scattering experiments Lord Rutherford concluded that most of the part of an atom is empty and that mass is concentrated in a very small region called nucleus.

## 21.1 ATOMIC NUCLEUS

At the centre of each and every atom there is an infinitesimally small nucleus. The entire positive charge of the atom and about 99.9 percent of its mass is concentrated in the nucleus. The tininess of the nucleus can be imagined by comparing that the radius of the atom is  $10^5$  times the radius of the nucleus.

A nucleus consists of nucleons comprising of protons and neutrons. A proton has a positive charge equal to  $1.6 \times 10^{-19} \text{ C}$  and its mass is  $1.673 \times 10^{-27} \text{ kg}$ . A neutron has no charge on it, but its mass is  $1.675 \times 10^{-27} \text{ kg}$ . The mass of a neutron is almost equal to mass of proton. To indicate the mass of atomic particles, instead of kilogram, unified mass scale ( $u$ ) is generally used. By definition  $1u$  is exactly one twelfth the mass of carbon<sup>12</sup> atom ( $1u = 1.6606 \times 10^{-27} \text{ kg}$ ). In this unit the mass of a proton is  $1.007276 u$  and that of a neutron is  $1.008665 u$  while that of an electron is  $0.00055 u$ .

The charge on a proton is equal in magnitude to the charge on an electron. The charge on the proton is positive while that of an electron is negative. As an atom on the whole is electrically neutral, therefore, we can conclude that the number of protons inside the nucleus is equal to the number of electrons outside the nucleus. The number of protons inside a nucleus is called the atomic number or the charge number of an atom. It is denoted by  $Z$ . Thus the total charge of any nucleus is  $Ze$ , here  $e$  indicates charge on one proton.

The combined number of all the protons and neutrons in a nucleus is known as its mass number and is denoted by  $A$ .

The number of neutrons  $N$  present in a nucleus is given by

$$N = (A - Z) \quad \dots \dots \dots (21.1)$$

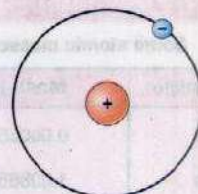


We now consider different elements of the periodic table. Hydrogen atom is simplest of all the atoms. Its nucleus is composed of only one proton; that is for hydrogen  $A = 1$ ,  $Z = 1$ . That is why hydrogen is represented by the symbol  ${}^1_1\text{H}$ . Next in the periodic table after the hydrogen element is the helium element. Its nucleus contains two protons and two neutrons. This means for helium  $A = 4$  and  $Z = 2$ ; and hence helium is represented as  ${}^4_2\text{He}$ . We now take the example of uranium - a heavy element of the periodic table. The charge number  $Z$  of uranium is 92 while its mass number  $A$  is 235. This is represented as  ${}^{235}_{92}\text{U}$ . It has 92 protons while the number of neutrons  $N$  is given by the equation  $N = A - Z = 235 - 92 = 143$ . In this way the number of protons and neutrons in atoms of all the elements of the periodic table can be determined. It has been observed that the number of neutrons and protons in the initial light elements of the periodic table is almost equal but in the later heavy elements the number of neutrons is greater than the number of protons in the nucleus.

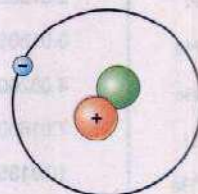
## 21.2 ISOTOPES

Isotopes are such nuclei of an element that have the same charge number  $Z$ , but have different mass number  $A$ , that is in the nucleus of such an element the number of protons is the same, but the number of neutrons is different. Helium, for example has two isotopes. These are symbolically represented as  ${}^3_2\text{He}$  and  ${}^4_2\text{He}$ . As the charge number of helium is 2, therefore, there are two protons in the helium nucleus. The neutron number of the first isotope is, according to Eq. 21.1 is  $3 - 2 = 1$  and that in the second isotope  ${}^4_2\text{He}$ , the number of neutron is  $4 - 2 = 2$ . Hydrogen has three isotopes represented by  ${}^1_1\text{H}$ ,  ${}^2_1\text{H}$ ,  ${}^3_1\text{H}$ . Its first isotope is called ordinary hydrogen or protium. There is only one proton in its nucleus. The second isotope of hydrogen is called deuterium. It has one proton and one neutron in its nucleus. Its nucleus is called deuteron. The third isotope of hydrogen has two neutrons and one proton in its nucleus and it is called tritium. The isotopes of hydrogen are shown in Figs. 21.1 (a,b,c).

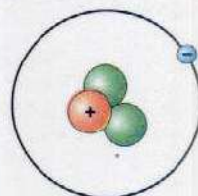
The chemical properties of all the isotopes of an element are alike, as the chemical properties of an element depend only upon the number of electrons around the nucleus, that is upon the charge number  $Z$ , which for all the isotopes of an element is the same. It is, therefore, not possible to separate the isotopes of an element by chemical methods. Physical methods are found to be successful for this purpose. A



(a)  ${}^1_1\text{H}$   
(Protium)



(b)  ${}^2_1\text{H}$   
(Deuterium)



(c)  ${}^3_1\text{H}$   
(Tritium)

Fig. 21.1

### Do You Know?

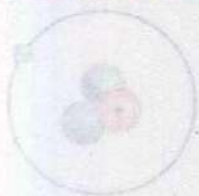
Both Xenon and caesium each have 36 isotopes.



### For Your Information

#### Some atomic masses

Particle	Mass (u)
e	0.00055
n	1.008665
$^1\text{H}$	1.007276
$^2\text{H}$	2.014102
$^3\text{H}$	3.01605
$^3\text{He}$	3.01603
$^4\text{He}$	4.002603
$^7\text{Li}$	7.016004
$^{10}\text{Be}$	10.013534
$^{14}\text{N}$	14.0031
$^{16}\text{O}$	16.9991



device with the help of which not only the isotopes of any element can be separated from one another but their masses can also be determined quite accurately is called mass spectrograph.

### Mass Spectrograph

A simple mass spectrograph is shown in Fig. 21.2 (a). The atoms or molecules of the element under investigation, in vapour form, are ionized in the ions source S. As a result of ionization, one electron is removed from the particle, leaving with a net positive charge +e. The positive ions, escaping the slit  $S_1$ , are accelerated through a potential difference  $V$  applied between the two slits  $S_1$  and  $S_2$ .

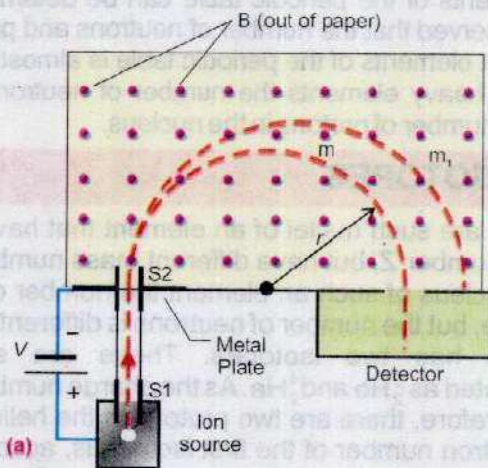


Fig. 21.2

The ions pass through the slit  $S_2$  in the form of a narrow beam. The K.E. of singly charged ion at the slit  $S_2$  will be given by

$$\frac{1}{2}mv^2 = Ve \quad \dots\dots\dots (21.2)$$

The ions are then subjected to a perpendicular and uniform magnetic field  $B$  in a vacuum chamber, where they are deflected in semicircular paths towards a detector. The detector records the number of ions arriving per second. The centripetal force applied by the magnetic field is given by

$$Bev = \frac{mv^2}{r} \quad \dots\dots\dots (21.3)$$

or

$$m = \frac{Ber}{v}$$

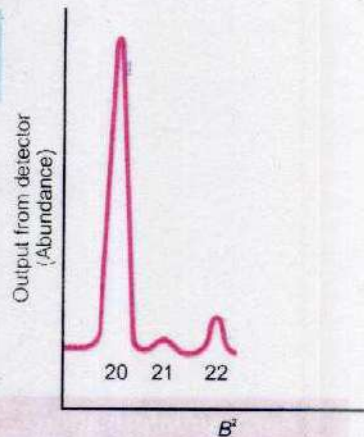


Substituting the values of  $v$  from Eq. 21.2, we get

$$m = \left( \frac{er^2}{2V} \right) B^2 \quad \dots\dots\dots (21.4)$$

The above equation shows that the mass of each ion reaching the detector is proportional to  $B^2$ . By adjusting the value of  $B$  and keeping the term in the parentheses constant, ions of different masses are allowed to enter the detector. A graph of the detector output as a function of  $B^2$  then gives an indication of what masses are present and the abundance of each mass.

Fig. 21.2 (b) shows a record obtained for naturally occurring neon gas showing three isotopes whose atomic mass numbers are 20, 21, and 22. The larger is the peak, the more abundant is the isotope. Thus most abundant isotope of neon is neon-20.



(b) (Proportional to atomic mass)

**Fig 21.2** The mass spectrum of naturally occurring neon, showing three isotopes whose atomic mass number are 20, 21, and 22. The larger the peak, the more abundant the isotope.

### 21.3 MASS DEFECT AND BINDING ENERGY

It is usually assumed that the whole is always equal to the sum of its parts. This is not so in the nucleus. The results of experiments on the masses of different nuclei show that the mass of the nucleus is always less than the total mass of all the protons and neutrons making up the nucleus. In the nucleus the missing mass is called the mass defect  $\Delta m$  given by

$$\Delta m = Z m_p + (A - Z) m_n - m_{\text{nucleus}} \quad \dots\dots\dots (21.5)$$

As  $Z$  is the total number of protons in the nucleus and  $m_p$  is the mass of a proton, then  $Z m_p$  is the total mass of all the protons. As shown in Eq. 21.1,  $(A - Z)$  is the total number of neutrons and as  $m_n$  is the mass of a single neutron,  $(A - Z) m_n$  is the total mass of all the neutrons. The term  $m_{\text{nucleus}}$  is the experimentally measured mass of the entire nucleus. Hence, Eq. 21.5 represents the difference in mass between the sum of the masses of its constituents and the mass of the nucleus itself.

The missing mass is converted to energy in the formation of the nucleus. This energy is found from Einstein's mass energy relation

$$E = (\Delta m) c^2 \quad \dots\dots\dots (21.6)$$

and is called the binding energy (B.E.) of the nucleus. From equations 21.5 and 21.6, the binding energy of a nucleus is

$$B.E. = (\Delta m) c^2 = Z m_p c^2 + (A - Z) m_n c^2 - m_{\text{nucleus}} c^2 \quad \dots (21.7)$$



Let us consider the example of the deuteron nucleus to make the concept of mass defect and binding energy more clear.

**Example 21.1:** Find the mass defect and binding energy of the deuteron nucleus. The experimental mass of deuteron is  $3.3435 \times 10^{-27}$  kg.

**Solution:**

Using equation 21.5, we get the mass defect of deuteron as

$$\begin{aligned} m &= m_p + m_n - m_D \\ &= 1.6726 \times 10^{-27} \text{ kg} + 1.6749 \times 10^{-27} \text{ kg} - 3.3435 \times 10^{-27} \text{ kg} \\ &= 3.9754 \times 10^{-30} \text{ kg} \end{aligned}$$

The B.E. of deuteron as found from Eq. 21.6 is  $\Delta m c^2$

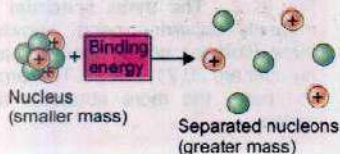
$$\Delta m c^2 = 3.9754 \times 10^{-30} \text{ kg} \times (3 \times 10^8 \text{ ms}^{-1})^2 = B.E. = 3.5729 \times 10^{-13} \text{ J}$$

To express the result in eV units, divide the B.E. obtained in joules by  $1.6 \times 10^{-19}$  J. Thus

$$B.E. = \frac{3.5729 \times 10^{-13} \text{ J}}{1.6 \times 10^{-19} \text{ J(eV)}^{-1}} = 2.33 \times 10^6 \text{ eV} = 2.23 \text{ MeV}$$

Therefore, the bound constituents have less energy than when they are free. That is the B.E. comes from the mass that is lost in the process of formation. Conversely, the binding energy is the amount of energy that must be supplied to a nucleus if the nucleus is to be broken up into protons and neutrons. Experiments have revealed that such mass defects exist in other elements as well. Shown in Fig. 21.3 is a graph between the mass defect per nucleon and charge

### For Your Information



Energy must be supplied to break the nucleus apart into its constituent protons and neutrons.

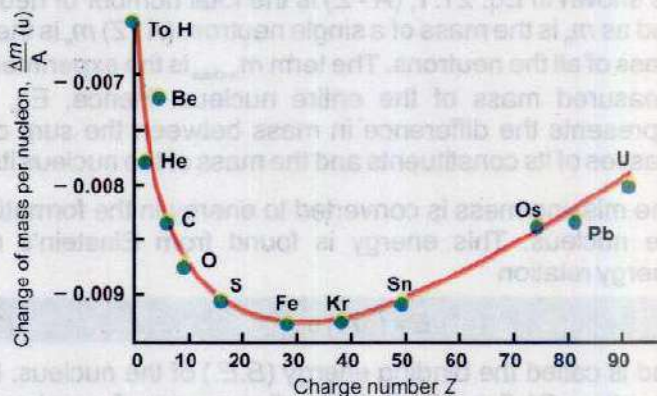


Fig. 21.3



number  $Z$  is obtained by finding the difference of mass between the total mass of all the protons and neutrons that form the nucleus and the experimental mass of the nucleus and dividing this difference by mass number  $A$ , i.e.,

Mass defect per nucleon

$$\frac{\Delta m}{A} = \frac{m_{\text{nucleus}} - [Zm_p + (A - Z)m_n]}{A}$$

where  $\Delta m$  is the mass defect. From the definition of mass defect it is quite obvious that for hydrogen, mass defect is zero. The mass defect is made clear with Einstein's equation  $E = \Delta mc^2$ . This equation shows that if for any reason a mass  $\Delta m$  is lost, then it is converted into energy.

Let us now calculate the BE of helium. For  ${}^4_2\text{He}$

$$\begin{aligned} \Delta m &= 2m_p + 2m_n - m_{\text{He}} \\ &= 2.01519 \text{ u} + 2.01796 \text{ u} - 4.00281 \text{ u} = 0.03034 \text{ u} \end{aligned}$$

since  $1 \text{ u} = 1.66 \times 10^{-27} \text{ kg}$

$$\therefore \Delta m = 0.03034 \text{ u} \times 1.66 \times 10^{-27} \text{ kg u}^{-1} = 5.03 \times 10^{-29} \text{ kg}$$

$$\begin{aligned} \text{Thus } B.E. &= \Delta mc^2 = 5.03 \times 10^{-29} \text{ kg} \times 9 \times 10^{16} \text{ m}^2 \text{ s}^{-2} \\ &= 4.5 \times 10^{-12} \text{ J} = \frac{4.5 \times 10^{-12} \text{ J}}{1.6 \times 10^{-19} \text{ J(eV)}^{-1}} = 2.82 \times 10^7 \text{ eV} = 28.2 \text{ MeV} \end{aligned}$$

This means that when two protons and two neutrons fuse together to make helium nucleus, if an amount of 28.2 MeV energy is given to the helium nucleus then it breaks up into two protons and two neutrons. From this, we conclude that

$$1 \text{ u} = 1.6606 \times 10^{-27} \text{ kg} = 931 \text{ MeV}$$

In this way we can calculate binding energy of every element. Shown in Fig. 21.4 is a graph between binding energy per nucleon and the mass number of different elements. This graph shows that the binding energy per nucleon increases

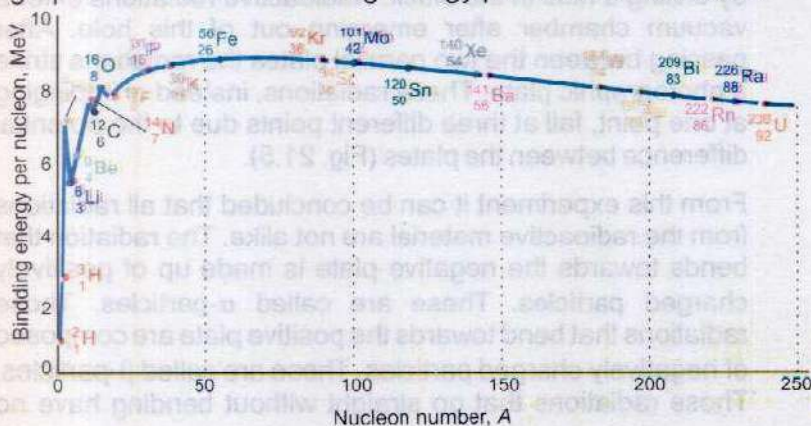
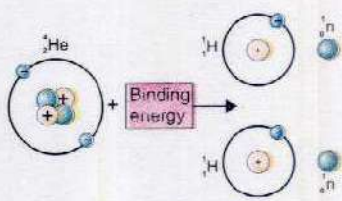


Fig. 21.4

For Your Information





with the mass number till it reaches a maximum value of 8.8 MeV at mass number 58 and then it gradually decreases to a value of 7.6 MeV at mass number 238. The binding energy per nucleon is maximum for iron. This shows that of all the elements iron is the most stable element. Later in this chapter it will be shown with the help of graph of Fig. 21.4 that when heavy element breaks into lighter elements or the lighter elements are fused to form heavier element then a large amount of energy can be obtained.

## 21.4 RADIOACTIVITY

It has been observed that those elements whose charge number  $Z$  is greater than 82 are unstable. Some invisible radiations, that can affect the photographic plates emanate out of these elements. Such elements are called radioactive and the phenomenon is called radioactivity. The radiations coming out of the radioactive elements are called alpha ( $\alpha$ ), beta ( $\beta$ ), and gamma ( $\gamma$ ) radiation. Radioactivity was discovered by Henri Becquerel in 1896. He found that an ore containing uranium ( $Z = 92$ ) emits an invisible radiation that penetrates through a black paper wrapping a photographic plate and affects the plate. After Becquerel's discovery Marie Curie and Pierre Curie discovered two new radioactive elements that they called polonium and radium.

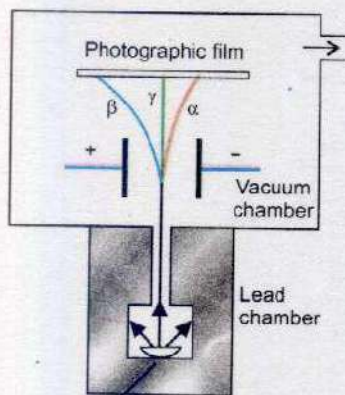


Fig. 21.5

Radioactive material

The analysis of the radiations emanating out of a radioactive material can be carried out by a simple experiment. The radioactive material is placed at the centre of a block of lead by drilling a hole in the block. Radioactive radiations enter a vacuum chamber after emerging out of this hole. After passing between the two parallel plates the radiations strike a photographic plate. These radiations, instead of impinging at one point, fall at three different points due to the potential difference between the plates (Fig. 21.5).

From this experiment it can be concluded that all radiations from the radioactive material are not alike. The radiation that bends towards the negative plate is made up of positively charged particles. These are called  $\alpha$ -particles. Those radiations that bend towards the positive plate are composed of negatively charged particles. These are called  $\beta$ -particles. Those radiations that go straight without bending have no



charge on them. These are called  $\gamma$ -rays.

Further experiments reveal that  $\alpha$ -particles are helium nuclei. The charge on them is  $+2e$  while their mass is  $4u$  (atomic mass unit) that is every  $\alpha$ -particle has two protons and two neutrons in it.  $\beta$ -particles are in fact fast moving electrons which come out of the nucleus of a radioactive element.  $\gamma$ -rays like X-rays, are electromagnetic waves which issue out of the nucleus of a radioactive element. The wavelength of these rays is much shorter, compared with the wavelength of X-rays.

## Nuclear Transmutation

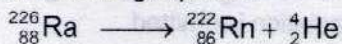
Radioactivity is purely a nuclear phenomenon. This is not affected by any physical or chemical reaction. Whenever any particle / radiation is emitted out of any radioactive element, it is always accompanied by some changes in the nucleus of the element. Therefore, this element changes into a new element. This phenomenon is called radioactive decay. The element formed due to this change is called daughter element. The original element is called the parent element. During the nuclear changes the laws of conservation of mass, energy, momentum and charge remain applicable.

We know that three types of radiations  $\alpha$ -particle,  $\beta$ -particle and  $\gamma$ -rays are emitted by the naturally occurring radioactive elements. When  $\alpha$ -particle is emitted out of any nucleus then due to law of conservation of matter, the mass number of the nucleus decreases by 4, and due to law of conservation of charge, the charge of the nucleus decreases by a magnitude of  $2e$  i.e., the charge number of the nucleus decreases by 2. It is due to the fact that the mass number and charge number of the emitted particle  $\alpha$  is 4 and 2 respectively. The emission of the  $\alpha$ -particle is represented by the following equation



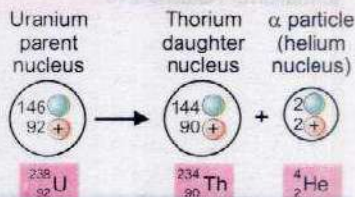
Here X represents the parent and Y the daughter element.

To explain the emission of  $\alpha$ -particles we take the example of radium  ${}^{226}_{88}\text{Ra}$ . The emission of an  $\alpha$ -particle from radium 226, results in the formation of radon gas  ${}^{222}_{86}\text{Rn}$ . This change is represented by the following equation



It may be remembered that the sum of the mass numbers and the charge numbers on both sides of the

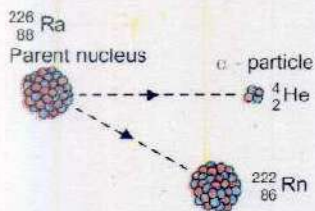
### For Your Information



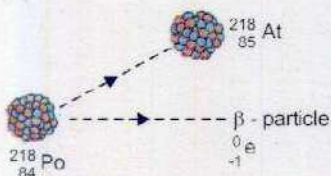
$\alpha$  - decay occurs when an unstable parent nucleus emits an  $\alpha$  - particle and in the process it is converted into a different (or daughter) nucleus.



### For Your Information



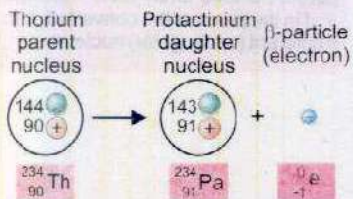
The emission of  $\alpha$ -particle from Radium-226 results in the formation of Radon-222 gas.



The emission of  $\beta$ -particle from Polonium-218 results in the formation of Astatine-218.



### Do You Know?



$\beta$ -decay occurs when a neutron in an unstable parent nucleus decays into a proton and an electron, the electron being emitted as the  $\beta$ -particle. In the process, the parent nucleus is transformed into daughter nucleus.

equation are equal. When a  $\beta$ -particle is emitted out of any nucleus, then its mass number does not undergo any change but its charge number increases by one. The emission of a  $\beta$ -particle from any element X is represented by the following equation



Negative  $\beta$ -particle is an electron and its emission from the nucleus becomes an incomprehensible enigma, as there is no electron present in the nucleus. However, the emission of electron from the nucleus can be thought of as a neutron emitting an electron and becoming a proton, although the modern explanation is not that simple.

This means that the  $\beta$ -particle is formed at the time of emission. That is why at the time of emission of a  $\beta$ -particle the charge number of the nucleus increases by one but no change in its mass number takes place as the mass of electron is exceedingly small as compared to the mass of a proton or a neutron. The transformation of an electron at the moment of its emission is given below by an equation



It has been observed that thorium  ${}_{90}^{234}\text{Th}$  is transformed into protactinium  ${}_{91}^{234}\text{Pa}$  after the emission of  $\beta$ -particle.

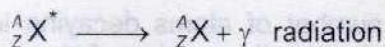
The following equation represents this reaction



When a  $\gamma$ -radiation issues out of nucleus then neither the charge number Z nor the mass number A of the nucleus undergoes any change. It is due to the fact that a  $\gamma$ -radiation is simply a photon that has neither any charge nor any mass. Its emission from the nucleus has some resemblance with the emission of a photon of light from an atom. We know that when any electron of an atom absorbs energy it jumps from the ground state to a higher energy state and the atom becomes excited. When the electron of this excited atom returns to its ground state then it emits the absorbed energy in the form of a photon. In much the same way the nucleus is sometimes excited to a higher state following the emission of  $\alpha$  or  $\beta$ -particle. This excited state of the nucleus is unstable state, in coming back to its ground state from the excited state,  $\gamma$ -radiation is emitted.

The emission of  $\gamma$ -radiation from a nucleus is generally represented by this equation





Here  ${}^A_Z X^*$  represents an excited nucleus while  ${}^A_Z X$  shows ground state of the nucleus.

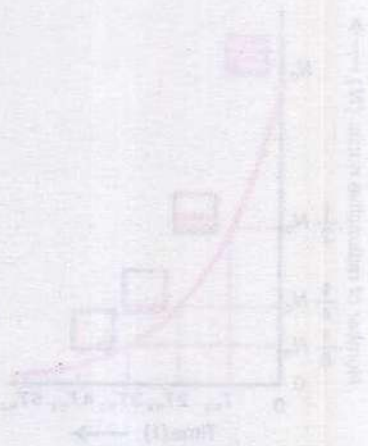
## 21.5 HALF LIFE

We have seen that whenever an  $\alpha$  or  $\beta$ -particle is emitted from a radioactive element, it is transformed into some other element. This radioactive decay process is quite random and is not subjected to any symmetry. This means that we cannot foretell about any particular atom as to when will it decay. It could decay immediately or it may remain unchanged for millions of year. Thus we cannot say anything about the life of any particular atom of a radioactive element.

Let us take the example of a city with a population of one million and we know that on the average ten person die every day. Even with this knowledge we cannot say with certainty that which particular person will die on which particular day. We can only say that on the whole ten person will die. The greater the population of the city, the greater the accuracy of such predictions. Like the population of a city, it is not possible to talk about an atom of a radioactive element. For more accurate result we always talk about large groups of atoms and laws of statistics are applied upon them. Let us suppose that we bring a group of 100,000 atoms under consideration and wait till such time that half of these i.e., 50,000 decay into their daughter element. This time is called the half-life  $T_{1/2}$  of this element. If the half-life of the said element be one day, then after one day only 25,000 atoms will remain behind and after two days 12,500 atoms will remain behind. That is with the passage of every one day, the number of atoms remaining behind becomes half of the number already present. This example provides us the definition of half-life of a radioactive element i.e.,

**"The half-life  $T_{1/2}$  of a radioactive element is that period in which half of the atoms decay".**

Besides getting the definition of half-life we can deduce two other conclusions from this example. These are, firstly no radioactive element can completely decay. It is due to the reason that in any half-life period only half of the nuclei decay and in this way an infinite time is required for all the atoms to decay.





Secondly, the number of atoms decaying in a particular period is proportional to the number of atoms present in the beginning of the period. If the number of atoms to start with is large then a large number of atoms will decay in this period and if the number of atoms present in the beginning is small then less atoms will decay.

We can represent these results with an equation. If at any particular time the number of radioactive atoms be  $N$ , then in an interval  $\Delta t$ , the number of decaying atom,  $\Delta N$  is proportional to the time interval  $\Delta t$  and the number of atoms  $N$ , i.e.,

$$\Delta N \propto -N \Delta t$$

$$\text{or} \quad \Delta N = -\lambda N \Delta t \quad \dots\dots\dots (21.8)$$

where  $\lambda$  is the constant of proportionality and is called decay constant. Eq. 21.8 shows that if the decay constant of any element is large then in a particular interval more of its atoms will decay and if the constant  $\lambda$  is small then in that very interval less number of atoms will decay. From Eq. 21.8 we can define decay constant  $\lambda$  as given below

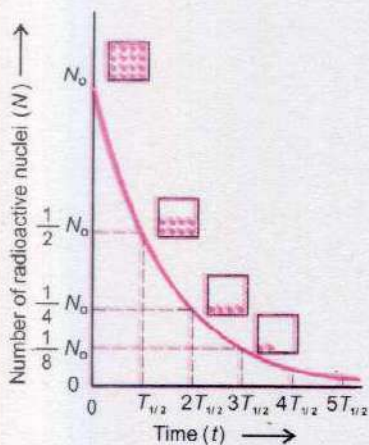
$$\lambda = -\frac{\Delta N/N}{\Delta t}$$

here  $\Delta N / N$  is the fraction of the decaying atoms. Thus decay constant of any element is equal to the fraction of the decaying atoms per unit time. The unit of the decay constant is  $s^{-1}$ . The negative sign in the Eq. 21.8 indicates the decrease in the number of atoms  $N$ .

The decay ability of any radioactive element can be shown by a graphic method also.

We know that every radioactive element decay at a particular rate with time. If we draw a graph between number of atoms in the sample of the radioactive element present at different times and the time then a curve as shown in Fig. 21.6 will be obtained. This graph shows that in the beginning the number of atoms present in the sample of the radioactive element was  $N_0$ , with the passage of time the number of these atoms decreased due to their decay. This graph is called decay curve.

After a period of one half-life  $N_0 / 2$  number of atoms of this radioactive element are left behind. If we wait further for another half-period then half of the remaining  $N_0 / 2$  atoms decay, and  $1/2 \times N_0 / 2 = (1/2)^2 N_0$  atoms remain behind. After



**Fig. 21.6** The half life  $T_{1/2}$  of a radioactive decay is the time in which one-half of the radioactive nuclei disintegrate.



the expiry of further period of a half-life, half of the remaining  $(1/2)^2 N_0$  atoms decay. The number of atoms that remain undecayed is  $1/2 \times (1/2)^2 N_0 = (1/2)^3 N_0$ . We can conclude from this example that if we have  $N_0$  number of any radioactive element then after a period of  $n$  half-lives the number of atoms left behind is  $(1/2)^n N_0$ .

It has been found that the estimate of decay of every radioactive element is according to the graph of Fig.21.6 but the half-life of every radioactive element is different. For example the half-life of uranium-238 is  $4.5 \times 10^9$  years while the half-life of radium-226 is 1620 years. The half-life of some radio active elements is very small, for example, the half-life of radon gas is 3.8 days and that of uranium-239 is 23.5 minutes.

From the above discussion it is found that the estimate of any radioactive element can be made from its half-life or by determining its decay constant  $\lambda$ . It can be proved with the help of calculus that the following relations exist between the decay constant  $\lambda$  and the half-life  $T_{1/2}$

$$\lambda T_{1/2} = 0.693 \dots\dots\dots (21.9)$$

Eq. 21.9 shows that if the decay constant  $\lambda$  of any radioactive element is known, its half-life can be found.

Any stable element, besides the naturally occurring radioactive element, can be made radioactive. For this very high energy particles are bombarded on the stable element. This bombardment excites the nuclei and the nuclei after becoming unstable become radioactive element. Such radioactive elements are called artificial radioactive elements.

**Example 21.2:** Iodine-131 is an artificial radioactive isotope. It is used for the treatment of human thyroid gland. Its half-life is 8 days. In the drug store of a hospital 20 mg of iodine-131 is present. It was received from the laboratory 48 days ago. Find the quantity of iodine-131 in the hospital after this period.

**Solution:**

As the half-life of iodine is 8 days, therefore in 8 days half of the iodine decays. Given below in the table is the amount of iodine present after every 8 days.



Interval in days	Quantity of Iodine	Interval in days	Quantity of Iodine
0	20 mg	32	1.25 mg
8	10 mg	40	0.625 mg
16	5 mg	48	0.3125 mg
24	2.5 mg		

Thus 48 days after the receipt, the amount of iodine-131 left behind is only 0.3125 mg.

## 21.6 INTERACTION OF RADIATION WITH MATTER

An  $\alpha$ -particle travels a well defined distance in a medium before coming to rest. This distance is called the range of the particle. As the particle passes through a solid, liquid or gas, it loses energy due to excitation and ionization of atoms and molecules in the matter. The ionization may be due to direct elastic collisions or through electrostatic attraction. Ionization is the main interaction with matter to detect the particle or to measure its energy. The range depends on the

- i. charge, mass and energy of the particle and
- ii. the density of the medium and ionization potentials of the atoms of the medium.

Since  $\alpha$ -particle is about 7000 times more massive than an electron, so it does not suffer any appreciable deflection from its straight path, provided it does not approach too closely to the nucleus of the atom. Thus  $\alpha$ -particle continues producing intense ionization along its straight path till it loses all its energy and comes almost to rest. It, then, captures two electrons from the medium and becomes a neutral helium atom.

$\beta$ -particles also lose energy by producing ionization. However, its ionizing ability is about 100 times less than that of  $\alpha$ -particles. As a result its range is about 100 times more than  $\alpha$ -particles.  $\beta$ -particles are more easily deflected by collisions than heavy  $\alpha$ -particles. Thus the path of  $\beta$ -particles in matter is not straight but shows much straggling or scattering. The range of  $\beta$ -particles is measured by the effective depth of penetration into the medium not by the length of erratic path. The more dense the material through which the particle moves, the shorter its range will be.



$\alpha$  and  $\beta$ -particles both radiate energy as X-ray photons when they are slowed by the electric field of the charged particles in a solid material.

Photons of  $\gamma$ -rays, being uncharged, cause very little ionization. Photons are removed from a beam by either scattering or absorption in the medium. They interact with matter in three distinct ways, depending mainly on their energy.

- (i) At low energies (less than about 0.5 MeV), the dominant process that removes photons from a beam is the photoelectric effect.
- (ii) At intermediate energies, the dominant process is Compton scattering.
- (iii) At higher energies (more than 1.02 MeV), the dominant process is pair production.

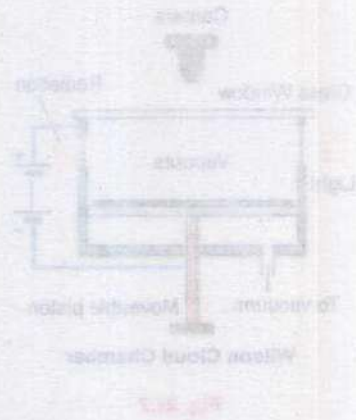
In air  $\gamma$ -rays intensity falls off as the inverse square of the distance from the source, in much the same manner as light from a lamp. In solids, the intensity decreases exponentially with increasing depth of penetration into the material. The intensity  $I_0$  of a beam after passing through a distance  $x$  in the medium is reduced to intensity  $I$  given by the relation  $I = I_0 e^{-\mu x}$

where  $\mu$  is the linear absorption coefficient of the medium. This coefficient depends on the energy of the photon as well as on the properties of the medium.

Charged particles  $\alpha$  or  $\beta$  and  $\gamma$ -radiation produce fluorescence or glow on striking some substance like zinc sulphide, sodium iodide or barium platinocyanide coated screens.

**"Fluorescence is the property of absorbing radiant energy of high frequency and re-emitting energy of low frequency in the visible region of electromagnetic spectrum".**

Neutrons, being neutral particles, are extremely penetrating particles. To be stopped or slowed, a neutron must undergo a direct collision with a nucleus or some other particle that has a mass comparable to that of the neutron. Materials such as water or plastic, which contain more low-mass nuclei per unit volume, are used to stop neutrons. Neutrons produce a little indirect ionization when they interact with materials containing hydrogen atoms and knock out protons.





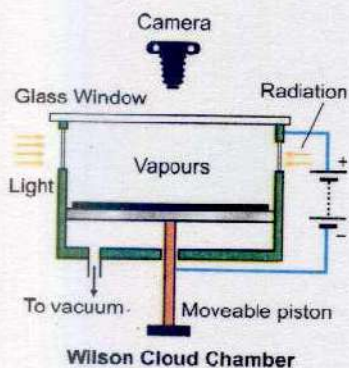
**Table 21.1** The summary of the nature of  $\alpha$ ,  $\beta$  &  $\gamma$  radiation

Characteristics	$\alpha$ -particles	$\beta$ -particles	$\gamma$ -rays
1. Nature	Helium nuclei of charge $2e$	Electrons or positrons from the nucleus of charge $\pm e$	E. M. waves from excited nuclei with no charge
2. Typical sources	Radon-222	Strontium-94	Cobalt-60
3. Ionization (Ion pairs $\text{mm}^{-1}$ in air)	About $10^4$	About $10^2$	About 1
4. Range in air	Several centimetres	Several metres	Obeys inverse-square law
5. Absorbed by	A paper	1-5 mm of Al sheet	1-10 cm of lead sheet
6. Energy spectrum	Emitted with the same energy	Variable energy	Variable energy
7. Speed	$\sim 10^7 \text{ ms}^{-1}$	$\sim 1 \times 10^8 \text{ ms}^{-1}$	$\sim 3 \times 10^8 \text{ ms}^{-1}$

## 21.7 RADIATION DETECTORS

Nuclear radiations cannot be detected by our senses, hence, we use some observable detecting methods employing the interaction of radiation with matter. Most detectors of radiation make use of the fact that ionization is produced along the path of the particle. These detectors include Wilson cloud chamber, Geiger counter and solid state detectors.

### Wilson Cloud Chamber



**Fig. 21.7**

It is a device which shows the visible path of an ionizing particle. It makes use of the fact that supersaturated vapours condense preferentially on ions. If an ionizing particle passes through a region in which cloud droplets are about to form, the droplets will form first along the particle's path, showing the path as a trail of droplets. The apparatus consists of a cylindrical glass chamber closed at the upper end by a glass window and at the lower end by a movable piston (Fig. 21.7). A black felt pad soaked in alcohol is placed on a metal plate inside the chamber. The air soon becomes saturated with alcohol vapours. A rapid expansion is produced by pulling quickly the piston of the bicycle pump having the leather washer reversed so that it removes air. The sudden cooling resulted from adiabatic expansion helps to form supersaturated vapours. As radiation passes through the chamber, ions are produced along the path. The tiny droplets



of moisture condense about these ions and form vapour tracks showing the path of the radiation. These are the atomic versions of the ice crystals left in the sky by a jet plane when suitable conditions exist. The fog tracks are illuminated with a lamp and may be seen or photographed through the glass window.

The  $\alpha$ -particles leave thick, straight and continuous tracks due to intense ionization produced by them as shown in Fig. 21.8 (a),  $\beta$ -particles form thin and discontinuous tracks extending in erratic manner showing frequent deflections (Fig. 21.8 b) and  $\gamma$ -rays leave no definite tracks along their path (Fig. 21.8 c). The length of the cloud tracks has been found proportional to the energy of the incident particle. A high potential difference of the order of 1 kV between the top and bottom of the chamber provides an electric field which clears away all the unwanted ions from the chamber to make it ready for use. The tracks seen are, therefore, those of rays that pass the chamber as the expansion occurs.

The chamber may be placed in a strong magnetic field which will bend the paths providing information about the charge, mass and energy of the radiating particle. In this way, it has helped in the discovery of many new particles.

### Geiger-Muller Counter

Geiger-Muller tube is a well-known radiation detector (Fig. 21.9 a). The discharge in the tube results from the ionization produced by the incident radiation. It consists of a stiff central wire acting as an anode in a hollow metal cylinder acting as a cathode filled with a suitable mixture of gas at about 0.1 atmospheric pressure. One end of the tube has a thin mica window to allow the entry of  $\alpha$  or  $\beta$ -particles and other end is sealed by non-conducting material and carries the connecting pins for the two electrodes. A high potential difference, (about 400 V for neon-bromine filled tubes) but slightly less than that

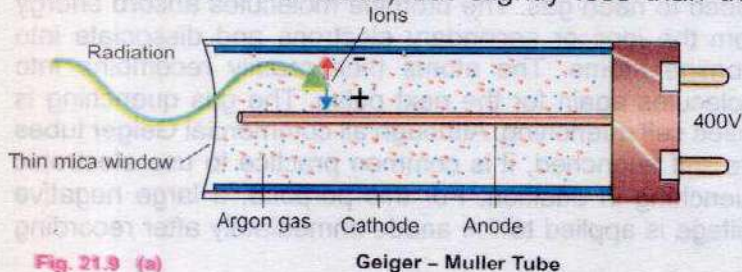
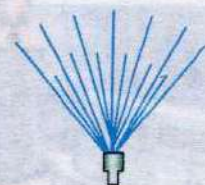


Fig. 21.9 (a)



(a)  $\alpha$ - Particle



(b)  $\beta$ - Particle



(c)  $\gamma$ -Rays

Fig. 21.8 Cloud chamber tracks of  $\alpha$ ,  $\beta$ ,  $\gamma$  radiations





(b) G.M. Tube with scaler unit

Fig. 21.9

necessary to produce discharge through the gas is maintained between the electrodes. When radiation enters the tube, ionization is produced. The free electrons are attracted towards the positively charged central wire. As they are accelerated towards the wire by a strong electric field, they collide with other molecules of the gas and knock out more electrons which in turn do the same and produce a cascade of electrons that move towards the central wire. This makes a short pulse of electric current to pass through an external resistor. It is amplified and registered electronically. The counter, which also provides the power, is called a scaler.

The cascade of electrons produced by the entry of an ionizing particle is counted as a single pulse of approximately of the same size whatever the energy or path of the particle maybe. It cannot, thus, discriminate between the energies of the incident particle as output pulses are same. The entire electron pulse takes less than  $1\mu$  s. However, positive ions, being very massive than the electrons, take several hundred times as long to reach the outer cathode. During this time, called the dead time ( $\sim 10^{-4}$  s) of the counter, further incoming particles cannot be counted. When positive ions strike the cathode, secondary electrons are emitted from the surface. These electrons would be accelerated to give further spurious counts. This is prevented by mixing a small amount of quenching gas with the principal gas.

The quenching gas must have an ionization potential lower than that of inert or principal gas. Thus, the ions of quenching gas reach the cathode before principal gas ions. When they reach near the cathode, they capture electrons and become neutral molecules. Following neutralization, the excess energy of the quenching molecules is dissipated in dissociation of the molecules rather than in the release of electrons from the cathode. For example, bromine gas is added to neon gas. The bromine molecules absorb energy from the ions or secondary electrons and dissociate into bromine atoms. The atoms then readily recombine into molecules again for the next pulse. The gas quenching is called self quenching. Although all commercial Geiger tubes are self quenched, it is common practice to use electronic quenching in addition. For this purpose, a large negative voltage is applied to the anode immediately after recording



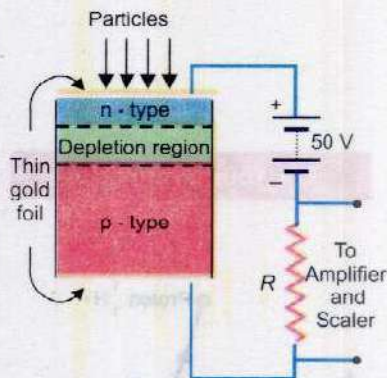
the output pulse. This reduces the electric field below the critical value for ionization by collision. The negative voltage remains until all the positive ions are collected at cathode thus preventing secondary pulses.

Geiger counter can be used to determine the range or penetration power of ionizing particles. The reduction in the count rate by inserting metal plates of varying thickness between the source and the tube helps to estimate the penetration power of the incident radiation.

Geiger counter is not suitable for fast counting. It is because of its relatively long "dead time" of the order of more than a millisecond which limits the counting rate to a few hundred counts per second. If particles are incident on the tube at a faster rate, not all of them will be counted since some will arrive during the dead time. Solid state detectors are fast enough, more efficient and accurate.

### Solid State Detector

A solid state detector is a specially designed p-n Junction (Fig. 21.10) operating under a reversed bias in which electron-hole pairs are produced by the incident radiation to cause a current pulse to flow through the external circuit. The detector is made from a p-type silicon or germanium. An n-type thin layer is produced by doping the top surface with donor type impurity. The top and bottom surfaces are coated with a thin layer of gold to make good conducting contact with external circuit. The combined thickness of n-type and gold layer absorbs so less energy of the incident particle that the junction may be assumed to be situated at the front surface. This is known as the surface barrier type detector. A reverse bias is applied through the two conducting layers of gold. This enlarges the charge free region around the junction called depletion region. Normally no current flows through the circuit. When an incident particle penetrates through the depletion region, it produces electron-hole pairs. These mobile charge carriers move towards the respective sides due to applied electric field. This gives rise to a current in the external circuit due to which a pulse of voltage is generated across the resistance  $R$ . This pulse is amplified and registered by a scaler unit. The size of the pulse is found proportional to the energy absorbed of the incident particle. The energy needed to produce an electron-hole pair is about 3 eV to 4 eV which makes the device useful for detecting low energy particles. The collection time of electrons and holes is much less than gas filled counters and hence a solid state detector can count very fast. It is much smaller in size than any other detector and operates at low voltage. The above mentioned type detector is used for detecting  $\alpha$  or  $\beta$ -particles but a specially designed device



Solid state detector  
Fig. 21.10



can be used for  $\gamma$ -rays.

## 21.8 NUCLEAR REACTIONS

While studying radioactivity, we have seen that an  $\alpha$  particle is emitted from radium-226 and radon-222 is obtained. This nuclear change is represented by the following equation



Such an equation represents a nuclear reaction. Above mentioned nuclear reaction takes place on its own accord. However, it was Rutherford who, first of all, expressed his opinion that besides natural radioactive decay processes, other nuclear reactions can also occur. A particle  $x$  is bombarded on any nucleus  $X$  and this process yields a nucleus  $Y$  and a light object  $y$  as given below



Rutherford performed an experiment on the nuclear reaction in 1918. He bombarded  $\alpha$ -particles on nitrogen. He observed that as a result of this reaction, oxygen is obtained and a proton is emitted. That is



This reaction indicated that when  $\alpha$ -particle enters the nucleus of  ${}_{7}^{14}\text{N}$ , then an excitation is produced in it. And as a result of it  ${}_{8}^{17}\text{O}$  and a proton are produced. Since the experiment of Rutherford, innumerable nuclear reactions have been observed. For nuclear reactions to take place, the fulfillment of certain conditions is a must.

Before and after any nuclear reaction the number of protons and neutrons must remain the same because protons and neutrons can neither be destroyed nor can they be created. We elaborate this point from the example of Rutherford's nuclear reaction of  ${}_{7}^{14}\text{N}$  and  ${}_2^4\text{He}$ , here

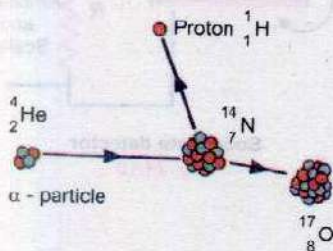


Number of protons =  $7 + 2 = 8 + 1$

Number of neutrons =  $7 + 2 = 9 + 0$

A nuclear reaction can take place only when the total energy of the reactants including the rest mass energy is equal to the total energy of the products. For its explanations we again take the example of the nuclear reaction of Rutherford involving  ${}_{7}^{14}\text{N}$  and  ${}_2^4\text{He}$ . In this reaction the mass of the reactants is

### For Your Information



An alpha-proton nuclear reaction



Mass of  ${}^{14}_7\text{N} = 14.0031 \text{ u}$

Mass of  ${}^4_2\text{He} = 4.0026 \text{ u}$

Total mass of the reactants = 18.0057 u

In the same way the mass of the products is

Mass of  ${}^{17}_8\text{O} = 16.9991 \text{ u}$

Mass of  ${}^1_1\text{H} = 1.0078 \text{ u}$

Total mass of the products after the reaction = 18.0069 u

This shows that the total mass after the reaction is greater than the total mass before the reaction by 0.0012 u. We know that a 1u mass = 931 MeV energy, therefore, a mass difference of 0.0012u is equivalent to an energy of 931 MeV  $\times$  0.0012 u = 1.13 MeV. Hence this reaction is possible only when an additional mass of 0.0012 u is added into the reactants or the minimum kinetic energy of the  $\alpha$ -particle is 1.13 MeV such as obtained from  ${}^{214}_{84}\text{Po}$ . The energy of these  $\alpha$ -particles is equal to 7.7 MeV which is greater than 1.13 MeV. Had these  $\alpha$ -particles been obtained from a source that give out  $\alpha$ -particles whose energy was less than 1.13 MeV then this reaction would not have taken place.

From the conditions described above we can tell whether any nuclear reaction is possible or not. There is an interesting aspect in a nuclear reaction that it can take place in the opposite direction also. We know that  ${}^{17}_8\text{O}$  is obtained by the interaction  ${}^{14}_7\text{N}$  with an  $\alpha$ -particle of appropriate energy. If we accelerate protons, with the help of a machine like cyclotron, and increase their velocity and then bombard these high velocity protons on  ${}^{17}_8\text{O}$ , Rutherford's nuclear reaction of  ${}^{14}_7\text{N}$  and  $\alpha$ -particle will proceed in the backward direction as



By bombarding different elements with  $\alpha$ -particles, protons and neutrons, many nuclear reactions have been produced. Now we describe one such nuclear reaction with the help of which James Chadwick discovered neutron in 1932. When  ${}^9_4\text{Be}$  was bombarded with  $\alpha$ -particles emitted out of  ${}^{210}_{84}\text{Po}$ , then as a result of a nuclear reaction,  ${}^{12}_6\text{C}$  and a neutron were obtained. This reaction is shown below with an equation



As neutron carries no charge, therefore, it presented a great amount of difficulty for its identification. Anyhow



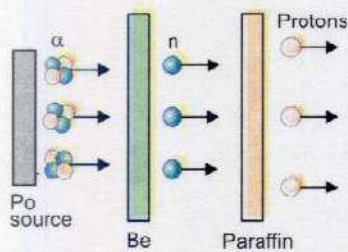


Fig. 21.11

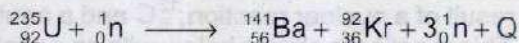
when neutrons were passed through a block of paraffin, fast moving protons were ejected out and these were easily identified. It may be remembered that a large amount of hydrogen is present in paraffin and the nuclei of hydrogen atoms are protons. The emission of protons is the consequence of elastic collisions between the neutrons and the protons. This indicates that the mass of neutron is equal to the mass of the proton. It may be remembered that when an object of certain mass collides with another object of equal mass at rest, then as a result of elastic collision, the moving object comes to rest and the stationary object begins to move with the velocity of the colliding object. The discovery of neutron has brought in a revolution in nuclear reactions, as the neutrons carry no charge so they can easily enter the nucleus. Fig. 21.11 shows the arrangement of Chadwick's experiment for the discovery of neutron.

## 21.9 NUCLEAR FISSION

Otto Hahn and Fritz Strassmann of Germany while working upon the nuclear reactions made a startling discovery. They observed that when slow moving neutrons are bombarded on  ${}^{235}_{92}\text{U}$ , then as a result of the nuclear reaction  ${}^{141}_{56}\text{Ba}$ ,  ${}^{92}_{36}\text{Kr}$  and an average of three neutrons are obtained. It may be remembered that the mass of both krypton and barium is less than that of the mass of uranium. This nuclear reaction was different from hitherto studied other nuclear reactions, in two ways. First as a result of the breakage of the uranium nucleus, two nuclei of almost equal size are obtained, whereas in the other nuclear reactions the difference between the masses of the reactants and the products was not large. Secondly a very large amount of energy is given out in this reaction.

**"Such a reaction in which a heavy nucleus like that of uranium splits up into two nuclei of roughly equal size along with the emission of energy during the reaction is called fission reaction".**

Fission reaction of  ${}^{235}_{92}\text{U}$  can be represented by the equation



here  $Q$  is the energy given out in this reaction. By comparing the total energy on the left side of the equation with total energy on the right side, we find that in the fission of one uranium nucleus about 200 MeV



energy is given out. It may be kept in mind that there is no difference between the sum of the mass and the charge numbers on both sides of the equation. Fission reaction is shown in Fig. 21.12 (a) and (b). Fission reaction can be easily explained with the help of graph of Fig. 21.4. This graph shows that the binding energy per nucleon is greatest for the middle elements of the periodic table and this binding energy per nucleon is a little less for the light or very heavy elements i.e., the nucleons in the light or very heavy elements are not so rigidly bound. For example the binding energy per nucleon for uranium is

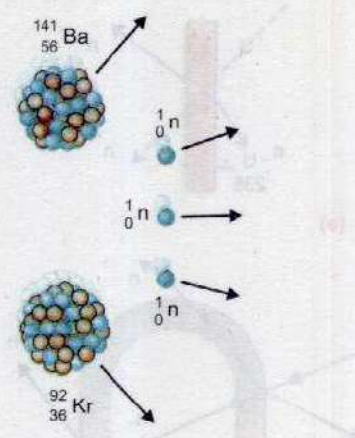
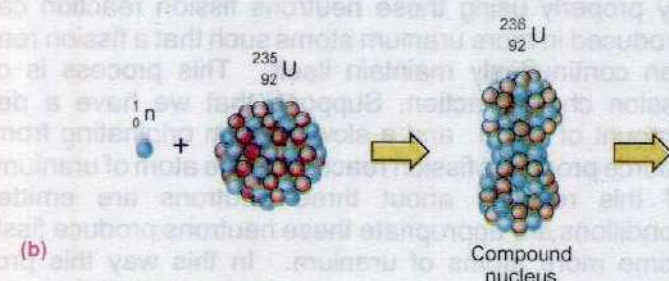
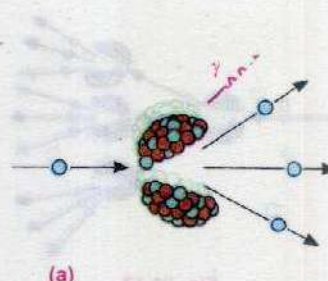
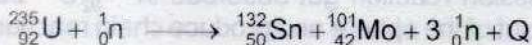


Fig. 21.12 Process of Fission reaction

about 7.7 MeV and the products of the fission reaction of uranium, namely barium and krypton, have binding energy of about 8.5 MeV per nucleon. Thus when a uranium nucleus breaks up, as a result of fission reaction, into barium and krypton, then an energy at the rate of  $(8.5-7.6) = 0.9$  MeV per nucleon is given out. This means that an energy  $235 \times 0.9 = 211.5$  MeV is given out in the fission of one uranium nucleus.

The fission process of uranium does not always produce the same fragments (Ba, Kr). In fact any of the two nuclei present in the upper horizontal part of binding energy could be produced. Two possible fission reactions of uranium are given below as an example:





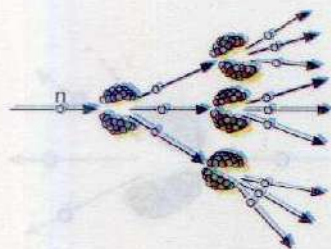
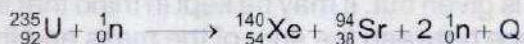


Fig. 21.13



Hence in the uranium fission reaction several products may be produced. All of these products (fragments) are radioactive. Fission reaction is not confined to uranium alone; it is possible in many other heavy elements. However, it has been observed that fission takes place very easily with the slow neutrons in uranium-235 and plutonium-239, and mostly these two are used for fission purposes.

### Fission Chain Reaction

We have observed that during fission reaction, a nucleus of uranium-235 absorbs a neutron and breaks into two nuclei of almost equal masses besides emitting two or three neutrons. By properly using these neutrons fission reaction can be produced in more uranium atoms such that a fission reaction can continuously maintain itself. This process is called fission chain reaction. Suppose that we have a definite amount of  ${}_{92}^{235}\text{U}$  and a slow neutron originating from any source produces fission reaction in one atom of uranium. Out of this reaction about three neutrons are emitted. If conditions are appropriate these neutrons produce fission in some more atoms of uranium. In this way this process rapidly proceeds and in an infinitesimal small time a large amount of energy along with huge explosion is produced. Fig.21.13 is the representation of fission chain reaction.

It is possible to produce such conditions in which only one neutron, out of all the neutrons created in one fission reaction, becomes the cause of further fission reaction. The other neutrons either escape out or are absorbed in any other medium except uranium. In this case the fission chain reaction proceeds with its initial speed. To understand these conditions carefully look at Fig. 21.14. In Fig. 21.14 (a) a fission reaction in a thin sheet of  ${}_{92}^{235}\text{U}$  is shown to be in progress. The resulting neutrons scatter in the air and so they cannot produce any fission chain reaction. Fig. 21.14 (b) shows some favourable conditions for chain reaction. Some of the neutrons produced in the first fission reaction produce only one more fission reaction but here also no chain reaction is produced. In Fig. 21.14 (c) a sphere of  ${}_{92}^{235}\text{U}$  is shown. If the sphere is sufficiently big, then most of the neutrons produced by the fission reaction get absorbed in  ${}_{92}^{235}\text{U}$  before they escape out of the sphere and produce chain reaction. Such a

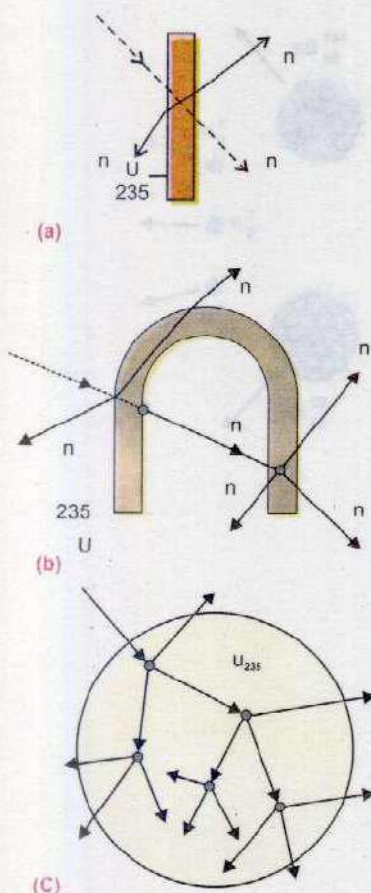


Fig 21.14



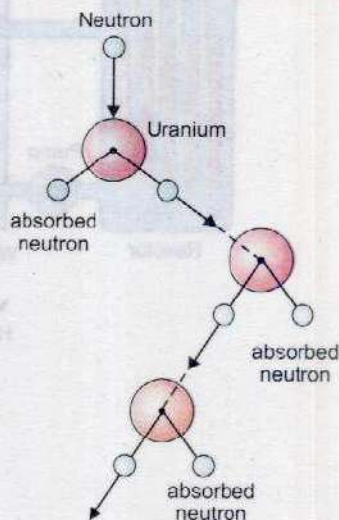
mass of uranium in which one neutron, out of all the neutrons produced in one fission reaction, produces further fission is called critical mass. The volume of this mass of uranium is called critical volume.

If the mass of uranium is much greater than the critical mass, then the chain reaction proceeds at a rapid speed and a huge explosion is produced. Atom bomb works at this principle. If the mass of uranium is less than the critical mass, the chain reaction does not proceed. If the mass of uranium is equal to the critical mass, the chain reaction proceeds at its initial speed and in this way we get a source of energy. Energy, in an atomic reactor, is obtained according to this principle. The chain reaction is not allowed to run wild, as in an atomic bomb but is controlled by a series of rods, usually made of cadmium, that are inserted into the reactor. Cadmium is an element that is capable of absorbing a large number of neutrons without becoming unstable or radioactive. Hence, when the cadmium control rods are inserted into the reactor, they absorb neutrons to cut down on the number of neutrons that are available for the fission process. In this way the fission reaction is controlled.

## Nuclear Reactor

In a nuclear power station the reactor plays the same part as does furnace in a thermal power station. In a furnace, coal or oil is burnt to produce heat, while in a reactor fission reaction produces heat. When fission takes place in the atom of uranium or any other heavy atom, then an energy at the rate of 200 MeV per nucleus is produced. This energy appears in the form of kinetic energy of the fission fragments. These fast moving fragments besides colliding with one another also collide with the uranium atoms. In this way their kinetic energy gets transformed in heat energy. This heat is used to produce steam which in turn rotates the turbine. Turbine rotates the generator which produces electricity. A sketch of a nuclear power station is shown in Fig. 21.15.

### For Your Information



In a controlled chain reaction, only one neutron, on average, from each fission event causes another nucleus to fission. As a result, energy is released at a steady or controlled rate.



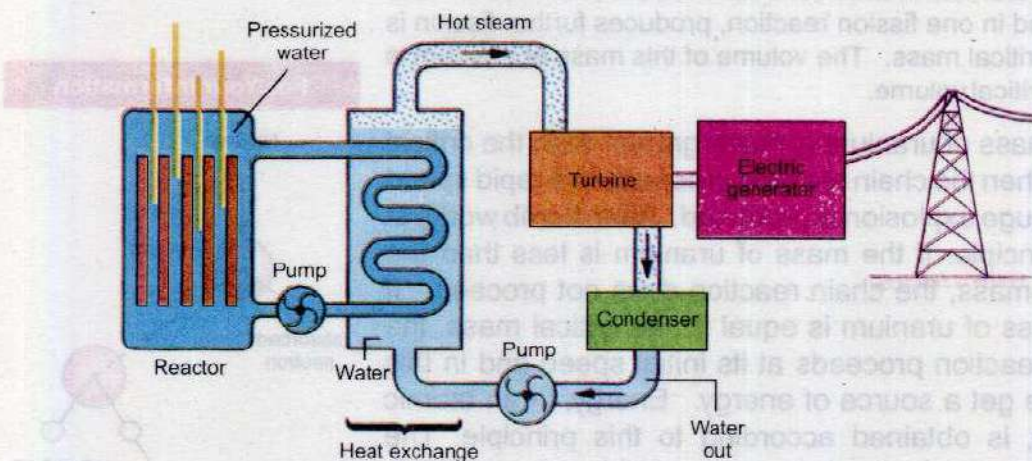


Fig. 21.15

A reactor usually has four important parts. These are:

1. The most important and vital part of a reactor is called core. Here the fuel is kept in the shape of cylindrical tubes. Reactor fuels are of various types. Uranium was used as fuel in the elementary reactors. In this fuel the quantity of  ${}^{235}_{92}\text{U}$  is increased from 2 to 4 percent. It may be remembered that the quantity of  ${}^{235}_{92}\text{U}$  in the naturally occurring uranium is only 0.7 percent. Now-a-days plutonium-239 and uranium-233 are also being used as fuel.
2. The fuel rods are placed in a substance of small atomic weight, such as water, heavy water, carbon or hydrocarbon etc. These substances are called moderators. The function of these moderators is to slow down the speed of the neutrons produced during the fission process and to direct them towards the fuel. Heavy water, it may be remembered, is made of  ${}^2_1\text{H}$ , a heavy isotope of hydrogen instead of  ${}^1_1\text{H}$ . The neutrons produced in the fission reaction are very fast and energetic and are not suitable for producing fission in reactor fuel like  ${}^{235}_{92}\text{U}$  or  ${}^{239}_{94}\text{Pu}$  etc. For this purpose slow neutrons are more useful. To achieve this, moderators are used.
3. Besides moderator there is an arrangement for the control of number of neutrons, so that of all the



neutrons produced in fission, only one neutron produces further fission reaction. The purpose is achieved either by cadmium or by boron because they have the property of absorbing fast neutrons. The control rods made of cadmium or boron are moved in or out of the reactor core to control the neutrons that can initiate further fission reaction. In this way the speed of the chain reaction is kept under control. In case of emergency or for repair purposes control rods are allowed to fall back into the reactor and thus stop the chain reaction and shut down the reactor.

- 4 Heat is produced due to chain reaction taking place in the core of the reactor. The temperature of the core, therefore, rises to about  $500^{\circ}\text{C}$ . To produce steam from this heat, it is transported to heat exchanger with the help of water, heavy water or any other liquid under high pressure. In the heat exchanger this heat is used to produce high temperature steam from ordinary water. The steam is then used to run the turbine which in turn rotates the generator to produce electricity. The temperature of the steam coming out of the turbine is about  $300^{\circ}\text{C}$ . This is further cooled to convert it into water again. To cool this steam, water from some river or sea is, generally, used. In Karachi nuclear power plant (KANUP), heavy water is being used as a moderator and for the transportation of heat also from the reactor core to heat exchanger, heavy water is used. To cool steam coming out of the turbine, sea water is being used.

The nuclear fuel once used for charging the reactor can keep on operation continuously for a few months. There after the fissile material begins to decrease. Now the used fuel is removed and fresh fuel is fed instead. In the used up fuel intensely radioactive substances remain. The half-life of these radioactive remnant materials is many thousand years. The radiations and the particles emitted out of this nuclear waste is very injurious and harmful to the living things. Unfortunately there is no proper arrangement of the disposal of the nuclear waste. This cannot be dumped into oceans or left in any place where they will contaminate the environment, such as through the soil or the air. They must not be allowed to get into the drinking water. The best place so far found to store these wastes is in the bottom of old salt



mines, which are very dry and are thousands of metres below the surface of the Earth. Here they can remain and decay without polluting the environment.

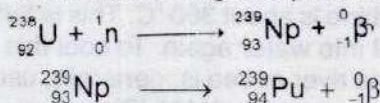
## Types of Reactors

There are two main types of nuclear reactors. These are:

- (i) Thermal reactors                      (ii) Fast reactors

The thermal reactors are called "thermal" because the neutrons must be slowed down to "thermal energies" to produce further fission. They use natural uranium or slightly enriched uranium as fuel. Enriched uranium contains a greater percentage of U-235 than natural uranium does. There are several designs of thermal reactors. Pressurized water reactors (PWR) are the most widely used reactors in the world. In this type of reactors, the water is prevented from boiling, being kept under high pressure. This hot water is used to boil another circuit of water which produces steam for turbine rotation of electricity generators.

Fast reactors are designed to make use of U-238, which is about 99% content of natural uranium. Each U-238 nucleus absorbs a fast neutron and changes to plutonium-239.



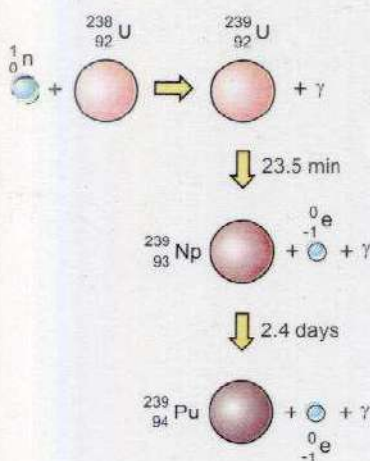
Plutonium can be fissioned by fast neutrons, hence, moderator is not needed in fast reactors. The core of fast reactors consists of a mixture of plutonium and uranium dioxide surrounded by a blanket of uranium-238.

Neutrons that escape from the core interact with uranium-238 in the blanket, producing thereby plutonium-239. Thus more plutonium fuel is bred in this way and natural uranium is used more effectively.

## 21.10 FUSION REACTION

We know that the energy given out per nucleon per fission of heavy element like that of uranium is 0.9 MeV. It is due to the fact that the binding energy per nucleon of the fission fragments is greater than uranium. In fact energy is obtained from any nuclear reaction in which the binding energy per nucleon of the products increases. Is there any other reaction besides the fission reaction from which energy could be obtained? In order to answer this question we must ponder

### Do You Know?



An induced nuclear reaction in which  ${}_{92}^{238}\text{U}$  is transmuted into the transuranium element plutonium  ${}_{94}^{239}\text{Pu}$ .



over Fig. 21.4 again. This graph shows that the binding energy per nucleon increases upto  $A = 50$ . Hence when two light nuclei merge together to form a heavy nucleus whose mass number  $A$  is less than 50, then energy is given out. In section on "Mass Defect and Binding Energy" we have observed that when two protons and two neutrons merge to form a helium nucleus, then about 28 MeV energy is given out.

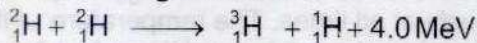
**"Such a nuclear reaction in which two light nuclei merge to form a heavy nucleus is called fusion reaction".**

During a fusion reaction some mass is lost and its equivalent energy is given out. In a fusion reaction, more energy per nucleon can be obtained as compared to the fission reaction. But unfortunately it is comparatively more difficult to produce fusion. Two positively charged light nuclei must be brought very close to one another. To do so work has to be done against the electrostatic force of repulsion between the positively charged nuclei. Thus a very large amount of energy is required to produce fusion reaction. It is true that a greater amount of energy can be obtained during a fusion reaction compared to that produced during a fission reaction, but in order to start this reaction a very large amount of energy is spent. On the contrary no difficulty is faced to start the fission reaction because neutron has no charge on it and it has to face no repulsive force while reaching the nucleus.

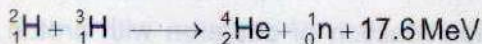
Let us now take the example of a fusion reaction when two deuterons are merged to form a helium nucleus, 24 MeV energy is released during this process i.e.,



But there is a very little chance of the formation of  ${}^4_2\text{He}$  nucleus by the merger of two deuterons. The probability of occurring such a reaction is great where one proton or one neutron is produced as given below:



In both of these reactions about 1.0 MeV energy per nucleon is produced which is equal to the energy produced during fission. If  ${}^2_1\text{H}$  and  ${}^3_1\text{H}$  are forced to fuse then 17.6 MeV energy is obtained i.e.,



We know that for fusion of two light nuclei the work has to be



### Do You Know?

Ozone on the surface of Earth is a corrosive and poisonous gas but at the height of 20-50 km from the Earth surface becomes vital to life as it absorbs almost all u.v. radiations which are harmful to living things.

### For Your Information

Ultra violet radiations cause

- (i) Sunburn, blindness and skin cancer
- (ii) Severe crop damage
- (iii) decay of micro-organisms
- (iv) disrupt the ocean ecosystem

done to overcome the repulsive force which exists between them. For this the two nuclei are hurled towards one another at a very high speed. One method to do so is to give these nuclei a very large velocity with the help of an accelerator. This method has been used in the research study of nuclear fusion of  ${}^2_1\text{H}$  and  ${}^3_1\text{H}$ . But this method of nuclear fusion for getting energy cannot be used on a large scale.

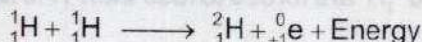
There is another method to produce fusion reaction. It is based upon the principle that the speed of atoms of a substance increases with the increase in the temperature of that substance. To start a fusion reaction the temperature at which the required speed of the light nuclei can be obtained is about 10 million degrees celsius. At such extraordinarily high temperature the reaction that takes place is called thermonuclear reaction. Ordinarily such a high temperature cannot be achieved. However during the explosion of an atom bomb this temperature can be had for a very short time.

Until now the fusion reaction is taking place only in a hydrogen bomb. That extraordinary high temperature is obtained during the explosion of an atom bomb, due to this high temperature the fusion reaction between  ${}^2_1\text{H}$  and  ${}^3_1\text{H}$  sets in. In this way a very large amount of energy is given out with the explosion.

A very large amount of energy can be had from a fusion reaction, but till now this reaction has not been brought under control like a fission reaction and so is not being used to produce electricity. Efforts are in full swing in this field and it is hoped that in near future some method would be found to control this reaction as well.

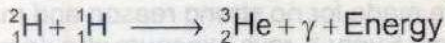
### Nuclear Reaction in the Sun

The Sun is composed primarily of hydrogen. It has a little amount of helium and a slight amount of other heavy elements. A tremendous amount of energy keeps issuing out of it continuously at all times. The temperature of its core is about 20 million degrees celsius and its surface temperature is about 6000 degrees celsius. Its energy is due to fusion reaction called p-p reaction. During this process two hydrogen nuclei or two protons fuse to form deuteron. This reaction takes place as

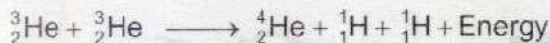


With the fusion reaction of deuteron with proton,  ${}^3_2\text{He}$  an isotope of helium is formed i.e.,





In the last stage the two nuclei of  ${}^3_2\text{He}$  react in the following manner:



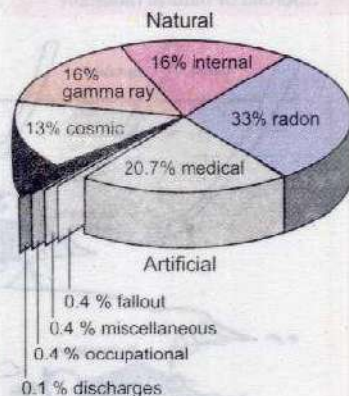
In this reaction six protons take part and finally a helium nucleus and two protons are formed. That is, the result of different stages of this reaction is that four protons have formed one helium nucleus. It has been estimated that in this p-p chain reaction, 25.7 MeV energy is given out i.e., 6.4 MeV per nucleon energy is obtained which is much greater than the energy given out per nucleon (1 MeV) during a fission reaction.

## 21.11 RADIATION EXPOSURE

When a Geiger tube is used in any experiment, it records radiation even when a radioactive source is nowhere near it. This is caused by radiation called background radiation. It is partly due to cosmic radiation which comes to us from outer space and partly from naturally occurring radioactive substance in the Earth's crust. The cosmic radiation consists of high energy charged particles and electromagnetic radiation. The atmosphere acts as a shield to absorb some of these radiations as well as ultraviolet rays. In recent past, the depletion of ozone layer in the upper atmosphere has been detected which particularly filters ultraviolet rays reaching us. This may result in increased eye and skin diseases. The depletion of ozone layer is suspected to be caused due to excessive release of some chemicals in the atmosphere such as chloroflourocarbons (CFC) used in refrigeration, aerosol spray and plastic foam industry. Its use is now being replaced by environmentally friendly chemicals. Many building materials contain small amounts of radioactive isotopes. Radioactive radon gas enters buildings from the ground. It gets trapped inside the building which makes radiation levels much higher from radon inside than outside. A good ventilation can reduce radon level inside the building. All types of food also contain a little radioactive substance. The most common are potassium-40 and carbon-14 isotopes.

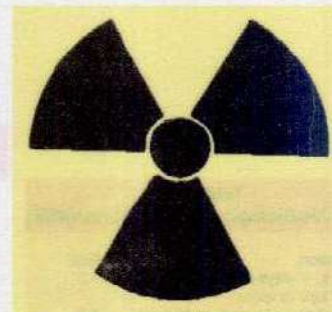
Some radiation in the environment is added by human activities. Medical practices, mostly diagnostic X-ray probably contribute the major portion to it. It is an unfortunate fact that many X-ray exposures such as routine chest X-ray

### For Your Information



Pie-chart showing proportion of radiation from different sources absorbed by average person.

### Do You Know?

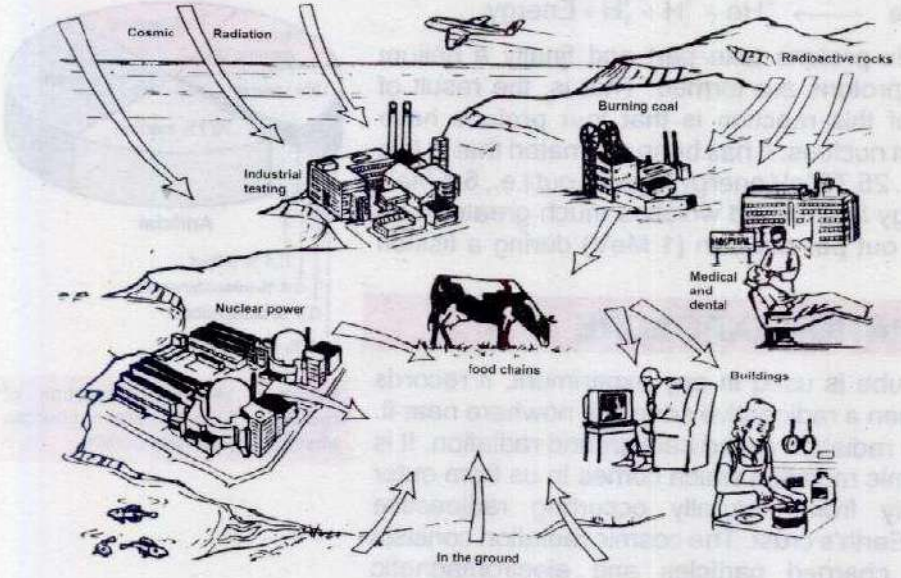


This symbol is universally used to indicate an area where radioactivity is being handled or artificial radiations are being produced.



**For Your Information**

**Sources of natural radiation**



and dental X-ray are made for no strong reason and may do more harm than good. Every X-rays exposure should have a definite justification that outweighs the risk. The other sources include radioactive waste from nuclear facilities,

hospitals, research and industrial establishments, colour television, luminous watches and tobacco leaves. A smoker not only inhales toxic smoke but also hazardous radiation. Low level background radiation from natural sources is normally considered to be harmless. However, higher levels of exposure are certainly damaging. We cannot avoid exposure to radiation. However, the best advice is to avoid unnecessary exposure to any kind of ionizing radiation.

**21.12 BIOLOGICAL EFFECTS OF RADIATION**

**Table 21.2**  
**Relative Biological Effectiveness (RBE)**

Radiation	RBE
X-rays, $\gamma$ -rays and $\alpha$ -particles of 30 keV or more	1.0
$\alpha$ -particles of less than 30 keV	1.7
Neutrons and protons below 10 MeV	10 (body) 30 (eyes)
$\alpha$ -particles from natural radioactivity	10
Heavy recoil nuclei	20

To study the effects of radiation, we need to define some of the units of radiation. The strength of the radiation source is indicated by its activity measured in becquerel (Bq). One becquerel is one disintegration per second. A larger unit is curie (Ci) which equals  $3.7 \times 10^{10}$  disintegrations per second. The effect of radiation on a body absorbing it relates to a quantity called absorbed dose, denoted as the energy  $E$  absorbed from ionizing radiation per unit mass  $m$  of the absorbing body.

$$D = \frac{E}{m} \dots \dots \dots (21.10)$$



Its SI unit is gray (Gy) defined as one joule per kilogram.

$$1 \text{ Gy} = 1 \text{ Jkg}^{-1}$$

An old unit is rad, an acronym for radiation absorbed dose.

$$1 \text{ rad} = 0.01 \text{ Gy}$$

Equal doses of different radiations do not produce same biological effect. For the same absorbed dose,  $\alpha$ -particles are 20 times more damaging than X-rays. The effect also depends on the part of the body absorbing the radiation. For example, neutrons are particularly more damaging to eyes than other parts of the body. To allow this, the absorbed dose is multiplied by a quality factor known as relative biological effectiveness or RBE (Table 21.2). The equivalent dose  $D_e$  of any absorbed radiation is defined as the product of absorbed dose and RBE of the kind of radiation being absorbed.

$$D_e = D \times \text{RBE} \quad \dots \dots \dots (21.11)$$

The SI unit of equivalent dose is sievert (Sv).

$$1 \text{ Sv} = 1 \text{ Gy} \times \text{RBE}$$

An old unit, the rem is equal to 0.01 Sv.

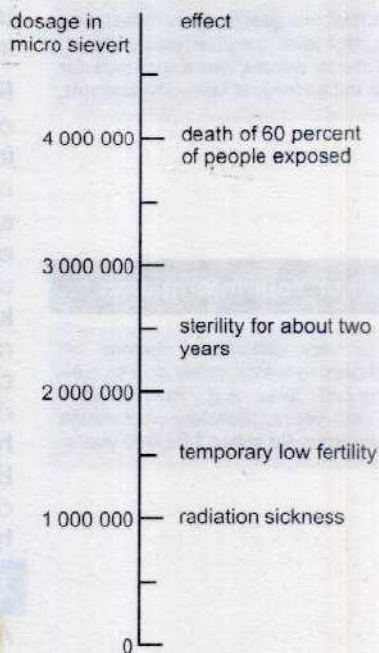
$$1 \text{ rem} = 0.01 \text{ Sv}$$

The background radiation to which we are exposed, on the average, is 2 mSv per year. Doses of 3 Sv will cause radiation burns to the skin. For workers in the nuclear facilities or mines, a weekly dose of 1 mSv is normally considered safe (Table 21.3).

The damage from  $\alpha$ -particles is small unless the source enters the body.  $\alpha$  and  $\beta$ -particles can cause redness and sores on the skin. Some other low level radiation effects are loss of hair, ulceration, stiffening of the lungs, and a drop in the white blood cells which is followed by a sickness pattern of diarrhea, vomiting and fever known as radiation sickness (Fig. 21.16). High levels of radiation may disrupt the blood cells seriously leading to diseases such as anaemia and leukaemia. Chromosome abnormalities or mutation may cause delayed genetic effects such as cancer, eye cataracts and abnormalities in the future generations. These may develop many years after exposure to harmful radiation.

**Example 21.3:** How much energy is absorbed by a man of mass 80 kg who receives a lethal whole body equivalent dose of 400 rem in the form of low energy neutrons for which RBE factor is 10?

Types of Exposure	mSv
Watching television for a year	10
Radiation from nuclear power stations for a year	10
Wearing a radioactive luminous watch for a year (now not very common)	30
Having a chest X-ray	200
Radiation from a brick house per year	750
Maximum dose allowed to general public from artificial sources per year	1000
Working for a month in a uranium mine	1000
Typical dose received by a member of the general public in a year from all sources	2500
Maximum dose allowed to workers exposed to radiation per year	50000



**Fig 21.16** The effects of exposure to high levels of ionizing radiation



### For Your Information



Film badge dosimeter are used to monitor radiation received by workers in nuclear facilities.

### Do You Know?

Radioactive wastes are of three types i.e., high level, medium and low level. All these wastes are dangerous for ground water and land environment.

### For Your Information

It is very difficult to dispose of radioactive waste safely due to their long half lives e.g., 'Pu' half life is 24,000 years, therefore, it remains dangerous for about 1,92,000 years.

### Solution:

RBE factor = 10

$$D_e = 400 \text{ rem} = 400 \times 0.01 \text{ Sv} = 4 \text{ Sv}, \quad D = ?$$

Using Eq. 21.4

$$D = \frac{D_e}{\text{RBE}} = \frac{4 \text{ Sv}}{10} = 0.4 \text{ Gy}$$

Since 1 Gy is  $1 \text{ J kg}^{-1}$ , hence total energy absorbed by the whole body =  $mD = 80 \times 0.4 \text{ Gy} = 32 \text{ J}$

It is a very small amount of thermal energy. Obviously, the damage done by ionizing radiation has nothing to do with thermal energy. The harmful effects arise due to disruption of the normal functions of the tissues in which it is absorbed.

## 21.13 BIOLOGICAL AND MEDICAL USES OF RADIATION

Radioisotopes of many elements can be made easily by bombardment with neutrons and other particles. As such isotopes have become available and are inexpensive, their use in medicine, agriculture, scientific research and industries has expanded tremendously.

Radioisotopes are used to find out what happens in many complex chemical reactions and how they proceed. Similarly in biology, they have helped in investigating into chemical reactions that take place in plants and animals. By mixing a small amount of radioactive isotope with fertilizer, we can easily measure how much fertilizer is taken up by a plant using radiation detector. From such measurements, farmers know the proper amount of fertilizer to use. Through the use of radiation-induced mutations, improved varieties of certain crops such as rice, chickpea, wheat and cotton have been developed. They have improved plant structure. The plants have shown more resistance to diseases and pest, and give better yield and grain quality. Radiation is also used to treat cancers. Radioactive tracers and imaging devices have helped in the understanding and diagnosis of many diseases.

### Tracer Techniques

A radioactive isotope behaves in just the same way as the normal isotope inside a living organism. But the location and concentration of a radioactive isotope can be determined easily by measuring the radiation it emits. Thus, a radioactive



isotope acts as an indicator or tracer that makes it possible to follow the course of a chemical or biological process. The technique is to substitute radioactive atoms for stable atoms of the same kind in a substance and then to follow the 'tagged' atoms with the help of radiation detector in the process. Tracers are widely used in medicine to detect malignant tumors and in agriculture to study the uptake of a fertilizer by a plant. For example, if a plant is given radioactive carbon-14, it will use it in exactly the same way as it always uses stable carbon-12. But the carbon-14 releases  $\beta$ -radiations and thus by measuring radioactivity in different parts of the plant, the path taken by the carbon atoms can be known. This technique has helped to understand more elaborately the complex process of photosynthesis. The tracer technique was also used to identify faults in the underground pipes of the fountain system of the historical Shalimar gardens of Lahore by the scientists of Pakistan Atomic Energy Commission.

**Table 21.4**

Isotope	Half-life	Gamma energies /MeV	Example of use
Sodium $^{24}\text{Na}$	15 hours	1.37, 2.75	Plasma volume
Iron $^{59}\text{Fe}$	45 days	1.29, 1.10 0.19	Iron in Plasma
Technetium $^{99}\text{Tc}$	6 hours	0.14	Thyroid uptake scans
Iodine $^{131}\text{I}$	8 days	0.72, 0.64 0.36, 0.28 0.08	Kidney tests
Iodine $^{125}\text{I}$	60 days	0.035	Plasma volume Vein flow

### Medical Diagnostics and Therapy

Tracers are widely used in medicine to study the process of digestion and the way chemical substances move about in the body.

Some chemicals such as hydrogen and sodium present in water and food are distributed uniformly throughout the body. Certain other chemicals are selectively absorbed by certain organs. Radio-iodine, for example, is absorbed mostly by the thyroid gland, phosphorus by bones and cobalt by liver. They can serve as tracers. Small quantity of low activity radioisotope mixed with stable isotope is administered by injection or otherwise to a patient and its location in diseased tissue can be ascertained by means of radiation detectors. For example, radioactive iodine can be used to check that a person's thyroid gland is working properly. A diseased or hyperactive gland absorbs more than twice the amount of normal thyroid gland. A similar method can be used to study the circulation of blood using radioactive isotope sodium-24.

Experiments on cancerous cells have shown that those cells that multiply rapidly absorb more radiation and are more easily destroyed than normal cells by ionizing radiation. Radiotherapy with  $\gamma$ -rays from cobalt-60 is often used in the treatment of cancer. The  $\gamma$ -rays are carefully focussed on to the malignant tissue. Strict safety precautions are necessary



for both patient and attendant medical staff. Radioactive iodine-131 is used to combat cancer of the thyroid gland. Since iodine tends to collect in the thyroid gland, radioactive isotopes lodge where they can destroy the malignant cells. In some cases encapsulated "seeds" are implanted in the malignant tissue for local and short ranged treatment. For skin cancers, phosphorus-32 or strontium-90 may be used instead. These produce  $\beta$ -radiation. The dose of radiation has to be carefully controlled otherwise the radiation could do more damage than help. Patients undergoing radiation treatment often feel ill, because the radiation also damages the healthy cells.

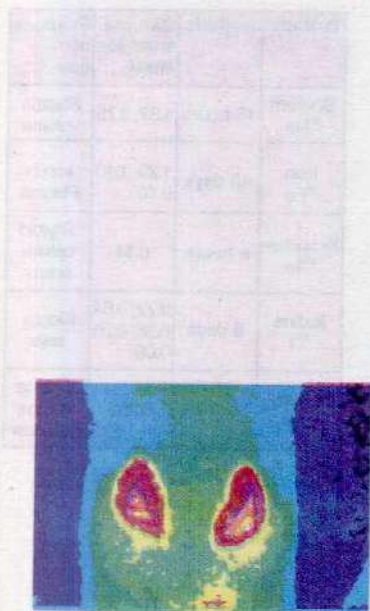


Fig. 21.17

### Radiography

The  $\gamma$ -rays radiographs are used in medical diagnosis such as internal imaging of the brain to determine precisely the size and location of a tumor or other parts of the body. Cracks or cavities in castings or pipes can also be detected by scanning. Any sudden increase in count rate indicates a cavity within the object.

The gamma camera is designed to detect  $\gamma$ -radiations from sites in the body where a  $\gamma$ -emitting isotope is located. An image as shown in Fig. 21.17, consisting of many dots of the  $\gamma$ -emitting sources in the patient body is formed. The camera can also be used to obtain a sequence of images to observe an organ such as a kidney in action.

## 21.14 BASIC FORCES OF NATURE

The man has always desired to comprehend the complexity of nature in terms of as few elementary concepts as possible. Among his quest, in Feynman's words, has been the one for "wheels within wheels", the task of Natural Philosophy being to discover the inner most wheels if any such exist. A second quest has concentrated itself with the fundamental forces, which make the wheels go round and enmesh with one another.

Although we have been familiar with the basic forces and about some of the basic building blocks of the matter, but here we are going to study the modern concepts about both of these. We know that the basic forces are:

1. Gravitational force
2. Magnetic force
3. Electric force
4. Weak nuclear force
5. Strong nuclear force



The electric and magnetic forces were unified to get an electromagnetic force by Faraday and Maxwell, who were able to prove that a current is induced in a coil whenever the magnetic flux passing through the coil is changed; leaving behind four fundamental forces, the strong nuclear force, the electromagnetic force, the weak nuclear force and the gravitational force. These four fundamental forces of nature have seemed for some time quite different from one another. Despite its different effective strength, the strong nuclear force is effective only within sub-nuclear distances and therefore, confines the neutrons and protons within the nucleus. The electromagnetic force is long-range and causes all chemical reactions. It binds together atoms, molecules, crystals, trees, buildings and you. This force acting on a microscopic level is responsible for a variety of apparently different macroscopic forces such as friction, cohesion and adhesion. The weak nuclear force is short range, like the strong nuclear force, and is responsible for spontaneous breaking up of the radioactive elements. It is a sort of repulsive force of very short range ( $10^{-17}$  m). It is usually masked by the effect of the strong and electromagnetic forces inside the nuclei. The gravitational force, like the electromagnetic force, is again long range, extending upto and beyond the remotest stars and galaxies. It keeps you, the atmosphere and the seas fixed to the surface of the planet. It gives rise to the ocean tides and keeps the planets moving in their orbits around the Sun.

These widely disparate properties of the four basic forces have not stopped the scientists from finding a common cause for them all.

One hundred years after the unification of electric and magnetic forces into electromagnetic force, in 1979, the physics nobel prize was conferred on Glashow, Weinberg and Abdus Slam for the unification of electromagnetic and weak forces.

It is further expected that a strong nuclear force will eventually unite with electroweak force to make up a single entity resulting in the grand unified electro-nuclear force.

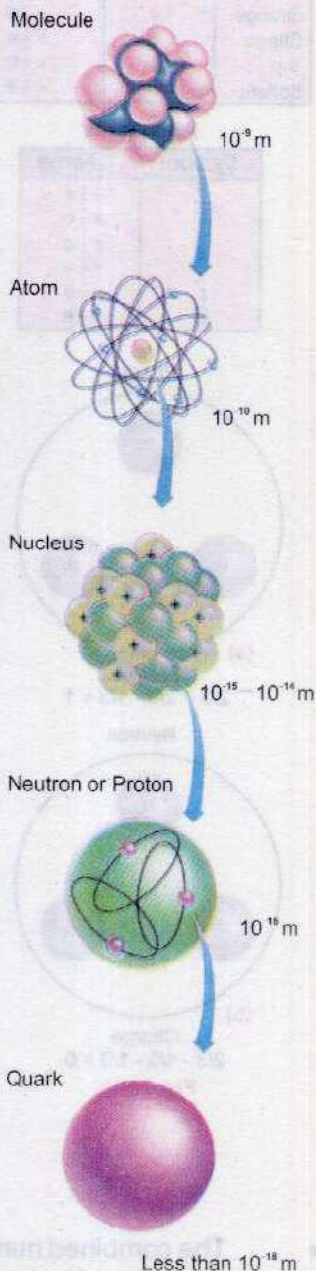
## 21.15 BUILDING BLOCKS OF MATTER

Subatomic particles are divided into three groups.

1. Photons
2. Leptons
3. Hadrons

### For Your Information

#### Composition of Matter



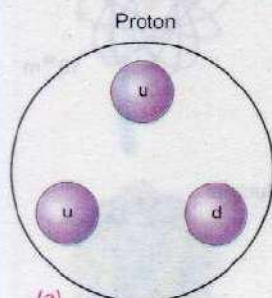


**Table 21.5**  
**Quarks and Antiquarks**

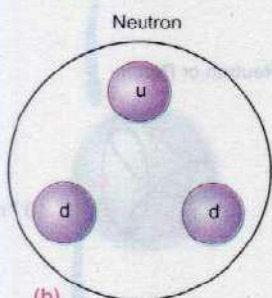
Name	Symbol	Charge
Up	$u$	$+\frac{2}{3}e$
Down	$d$	$-\frac{1}{3}e$
Strange	$s$	$-\frac{1}{3}e$
Charm	$c$	$+\frac{2}{3}e$
Top	$t$	$+\frac{2}{3}e$
Bottom	$b$	$-\frac{1}{3}e$

**Antiquarks**

Symbol	Charge
$\bar{u}$	$-\frac{2}{3}e$
$\bar{d}$	$+\frac{1}{3}e$
$\bar{s}$	$+\frac{1}{3}e$
$\bar{c}$	$-\frac{2}{3}e$
$\bar{t}$	$-\frac{2}{3}e$
$\bar{b}$	$+\frac{1}{3}e$



(a)  
Charge  
 $2/3 + 2/3 - 1/3 = 1$



(b)  
Charge  
 $2/3 - 1/3 - 1/3 = 0$

**Fig. 21.18**

Elementary particles are the basic building blocks of matter. All photons and leptons are elementary particles. Hadrons are not elementary particles but are composed of elementary particles called quarks. Scientists now believe that all matter belongs to either the quark group or the lepton group.

**Hadrons**

Hadrons are particles that experience the strong nuclear force. In addition to protons, neutrons and mesons are hadrons. The particles equal in mass or greater than protons are called baryons and those lighter than protons are called mesons.

**Leptons**

Leptons are particles that do not experience strong nuclear force. Electron, muons and neutrinos are leptons.

**Quarks**

According to quark theory initiated by M. Gell-Mann and G. Zweig, the quarks are proposed as the basic building blocks of the mesons and baryons. A pair of quark and antiquark makes a meson and 3 quarks make a baryon. It is proposed that there are six quarks, the (1) up (2) down (3) strange (4) charm (5) bottom and, (6) top. The charges on these quarks are fractional as shown in Table 21.5.

A proton is assumed to be made up of two up quarks and one down quark as shown in Fig. 21.18 a. The neutron is assumed to be made of one up quark and two down quarks as shown in Fig. 21.18 (b). Currently, the hundred of hadrons can be accounted for in terms of six quarks and their antiquarks. It is believed that quarks cannot exist on their own, their existence has been indirectly verified.

**SUMMARY**

- The combined number of all the protons and neutrons in a nucleus is known as mass number and is denoted by A.



- The protons and neutrons present in the nucleus are called nucleons.
  - The number of neutrons present in a nucleus is called its neutrons number and is denoted by  $N$ .
  - The number of protons inside a nucleus or the number of electrons outside of the nucleus is called the atomic number or the charge number of an atom and is denoted by  $Z$ .
  - Isotopes are such nuclei of an element that have the same charge number  $Z$ , but have different mass number  $A$ .
  - The mass of the nucleus is always less than the total mass of the protons and neutron that make up the nucleus. The difference of the two masses is called mass defect. The missing mass is converted to energy in the formation of the nucleus and is called the binding energy.
  - The emission of radiations ( $\alpha$ ,  $\beta$  and  $\gamma$ ) from elements having charge number  $Z$  greater than 82 is called radioactivity.
  - The change of an element into a new element due to emission of radiations is called radioactive decay. The original element is called parent element and the element formed due to this decay is called daughter element.
  - Half-life of a radioactive element is that period in which half of the atoms of the parent element decay into daughter element.
  - Such a reaction in which a heavy nucleus like uranium splits up into two nuclei of equal size along with the emission of energy during reaction is called fission reaction.
  - Such a nuclear reaction in which two light nuclei merge to form a heavy nucleus along with the emission of energy is called fusion reaction.
  - The strength of the radiation source is indicated by its activity measured in becquerel. One becquerel (Bq) is one disintegration per second. A larger unit is curie (Ci) which equals  $3.7 \times 10^{10}$  disintegrations per second.
  - The effect of radiation on a body absorbing it relates to a quantity called absorbed dose  $D$  defined as the energy  $E$  absorbed from ionizing radiation per unit mass  $m$  of the absorbing body.
  - The basic forces are:
 

i. Gravitational force	ii. Electromagnetic force
iii. Weak nuclear force	iv. The strong force
  - Subatomic particles are divided into following three groups:
 

i. Photons	ii. Leptons	iii. Hadrons
------------	-------------	--------------
- Elementary particles are the basic building blocks of matter.



## QUESTIONS

- 21.1 What are isotopes? What do they have in common and what are their differences?
- 21.2 Why are heavy nuclei unstable?
- 21.3 If a nucleus has a half-life of 1 year, does this mean that it will be completely decayed after 2 years? Explain.
- 21.4 What fraction of a radioactive sample decays after two half-lives have elapsed?
- 21.5 The radioactive element  ${}^{226}_{88}\text{Ra}$  has a half-life of  $1.6 \times 10^3$  years. Since the Earth is about 5 billion years old, how can you explain why we still can find this element in nature?
- 21.6 Describe a brief account of interaction of various types of radiations with matter.
- 21.7 Explain how  $\alpha$  and  $\beta$ -particles may ionize an atom without directly hitting the electrons? What is the difference in the action of the two particles for producing ionization?
- 21.8 A particle which produces more ionization is less penetrating. Why?
- 21.9 What information is revealed by the length and shape of the tracks of an incident particle in Wilson cloud chamber?
- 21.10 Why must a Geiger Muller tube for detecting  $\alpha$ -particles have a very thin end window? Why does a Geiger Muller tube for detecting  $\gamma$ -rays not need a window at all?
- 21.11 Describe the principle of operation of a solid state detector of ionizing radiation in terms of generation and detection of charge carriers.
- 21.12 What do we mean by the term critical mass?
- 21.13 Discuss the advantages and disadvantages of nuclear power compared to the use of fossil fuel generated power.
- 21.14 What factors make a fusion reaction difficult to achieve?
- 21.15 Discuss the advantages and disadvantages of fission power from the point of safety, pollution and resources.
- 21.16 What do you understand by "background radiation"? State two sources of this radiation.
- 21.17 If someone accidentally swallows an  $\alpha$ -source and a  $\beta$ -source which would be the more dangerous to him? Explain why?
- 21.18 Which radiation dose would deposit more energy to the body (a) 10 mGy to the hand, or (b) 1 mGy dose to the entire body.
- 21.19 What is a radioactive tracer? Describe one application each in medicine, agriculture and industry.
- 21.20 How can radioactivity help in the treatment of cancer?



## PROBLEMS

- 21.1 Find the mass defect and the binding energy for tritium, if the atomic mass of tritium is 3.016049 u. (Ans: 0.00857 u, 7.97 MeV)
- 21.2 The half-life of  $^{91}_{38}\text{Sr}$  is 9.70 hours. Find its decay constant. (Ans:  $1.99 \times 10^{-5} \text{ s}^{-1}$ )
- 21.3 The element  $^{234}_{91}\text{Pa}$  is unstable and decays by  $\beta$ -emission with a half-life 6.66 hours. state the nuclear reaction and the daughter nuclei. (Ans:  $^{234}_{92}\text{U}$ )
- 21.4 Find the energy associated with the following reaction: (Mass of  $^1_1\text{H}=1.00784 \text{ u}$ )
- $$^{14}_7\text{N} + ^4_2\text{He} \longrightarrow ^{17}_8\text{O} + ^1_1\text{H}$$
- What does negative sign indicate? (Ans: 1.12 MeV)
- 21.5 Determine the energy associated with the following reaction: (mass of  $^{14}_6\text{C}=14.0077 \text{ u}$ )
- $$^{14}_6\text{C} \longrightarrow ^{14}_7\text{N} + ^0_{-1}\text{e}$$
- (Ans: 3.77 MeV)
- 21.6 If  $^{233}_{92}\text{U}$  decays twice by  $\alpha$ -emission, what is the resulting isotope? (Ans:  $^{225}_{88}\text{Rn}$ )
- 21.7 Calculate the energy (in MeV) released in the following fusion reaction:
- $$^2_1\text{H} + ^3_1\text{H} \longrightarrow ^4_2\text{He} + ^1_0\text{n}$$
- (Ans: 17.6 MeV/event)
- 21.8 A sheet of lead 5.0 mm thick reduces the intensity of a beam of  $\gamma$ -rays by a factor 0.4. Find half value thickness of lead sheet which will reduce the intensity to half of its initial value. (Ans: 3.79 mm)
- 21.9 Radiation from a point source obeys the inverse square law. If the count rate at a distance of 1.0 m from Geiger counter is 360 counts per minute, what will be its count rate at 3.0 m from the source? (Ans: 40 counts per min.)
- 21.10 A 75 kg person receives a whole body radiation dose of 24 m-rad, delivered by  $\alpha$ -particles for which RBE factor is 12. Calculate (a) the absorbed energy in joules, and (b) the equivalent dose in rem. (Ans: (a) 18 mJ (b) 0.29 rem)

**Note:** Consult the table on page 222, where required, for atomic masses.



## GLOSSARY

- **Alternating Current** Current produced by a voltage source whose polarity keeps on reversing with time
- **Amorphous** Those solids in which arrangement of atoms or molecules are not regular
- **Amplifier** A device that increases the output of electrical signal fed as input
- **Atomic Number** The number of protons in the nucleus
- **Binding Energy** The work done on the nucleus to separate it into its constituent neutrons and protons
- **Black Body** A body that absorbs all the radiations incident upon it
- **Bulk Modulus** Ratio of applied stress to volumetric strain
- **Capacitor** A device that can store charge
- **Cathode ray Oscilloscope** High speed graph plotting device
- **Compton effect** An increase in the wavelength of X-rays when scattered by bound electrons.
- **Crystalline Solids** Substances having regular arrangement of atoms or molecules
- **Current Generator** A device which converts mechanical energy into electrical energy
- **Digital System** It deals with only those quantities which have only two discrete values
- **Elastic limit** The limit beyond which the sample becomes permanently deformed
- **Electric Current** Rate of flow of electric charge
- **Electric Field Intensity** Electric field force per unit charge at a point



- **Electric Flux**      Number of electric field lines passing through certain surface element
- **Electric Potential**      Amount of work done in bringing a unit positive charge from infinity to a point
- **Electrolysis**      Conduction of electricity due to chemical reaction in liquids
- **Electromagnetic Waves**      Waves which do not require any medium for their propagation
- **Electromotive Force**      A measure of the energy supplied by a source of electric current per unit charge
- **Electron volt**      Unit of energy equals to  $1.6 \times 10^{-19} \text{ J}$
- **Electroplating**      Electric metallic coating
- **Forward Bias**      Bias voltage which when applied to a p – n junction produce large current flow
- **Frequency**      Number of cycles per unit time
- **Fusion**      Such nuclear reaction in which two light nuclei merge to form a heavy nucleus with the emission of energy
- **Half life**      It is the period in which half of the radioactive element atoms decay
- **Holography**      A method of recording three dimensional image
- **Impedance**      Combined effect of resistances and reactances in an A.C. circuit
- **Inductance**      The phenomenon in which changing current in a coil produces an emf in itself
- **Inertial frame of reference**      Coordinate system in which the law of inertia is valid
- **Insulators**      A material with a very high electrical resistivity
- **Ionization Potential**      The energy needed to remove the electron from an atom or molecule to infinite distance



- **Laser** Light amplification by stimulated emission of radiation
- **Logic Gate** Electronic circuits which implements various logic operations
- **Magnetic Induction** Magnetization of a substance by an external magnetic field
- **Mass Defect** It is the difference between the mass of the separated nucleons and the combined mass of the nucleus
- **Mass Number** Total number of protons and neutrons in a nucleus
- **Modulation** The process of combining the low frequency signal with a high frequency radio wave
- **Mutual Inductance** A phenomenon in which a changing current in one coil produces emf in other coil
- **NAVASTAR** Navigation system based on Einstein theory of relativity
- **Nuclear Energy** Energy derived from nuclear reactions either by fission or by fusion
- **Nuclear fission** Disintegration of atomic nucleus into two or more fragments with the emission of huge amount of energy
- **Nuclear Reactor** A device in which controlled nuclear fission reaction takes place
- **Nucleons** Protons and neutron in the nucleus.
- **Pair Production** Production of electron-positron pair from a photon
- **Photo voltaic cell** A device that detects or measures electromagnetic radiation by generating a potential at a junction
- **Photodiode** A device used to detect light falling on it
- **Photoelectric Effect** Emission of electrons from metallic surface when exposed to electromagnetic radiations
- **Plastic deformation** A permanent deformation of a solid object to an applied stress



- **Polymeric Solids**      The solid materials with a structure that is in intermediate between ordered and disordered structure
- **Rectification**      Conversion of alternating current into direct current
- **Resistivity**      Tendency of material to oppose the flow of current
- **Reverse Bias**      Bias voltage which when applied to a p – n junction produces a very small or no current flow
- **Spectrograph**      An instrument for producing photographic record of spectrum
- **Spectroscopy**      The investigation of wavelength and intensities of electromagnetic radiations emitted or absorbed by the atoms
- **Strain**      The change produced in the size or shape of the body by applying a stress
- **Stress**      Force per unit area
- **Super Conductors**      Those material whose resistivity becomes zero below a critical temperature
- **Thermistor**      Heat sensitive resistor
- **Time Period**      That interval during which the voltage source changes its polarity once
- **Transformer**      A device which converts high A.C. voltage to low A. C. voltage or low A.C. voltage to high A. C. voltage
- **Transistor**      Semi conducting material to which at least three electrical contacts are made
- **Ultimate tensile stress**      The maximum stress that a material can withstand
- **Young's Modulus**      Ratio of the tensile stress applied to the material to the resulting tensile strain



## BIBLIOGRAPHY

1. College Physic by Harris Benson.
2. Physics for Scientist and Engineers by Raymond A. Serway.
3. Physics Concepts and Applications by Jerry Wilson.
4. The Ideas of Physics by Douglas G. Giancoli.
5. Conceptual Physics by Paul G. Hewitt.
6. College Physic by Robert. L.Weber.
7. Cambridge Physics by Jones and Marchington.
8. Principles of Physics by F.J. Bueche and David A. Jerde.
9. Fundamentals of Physics by David Holliday, Robert Resnik and Jearl Walker.
10. Advanced Physics by Jonathan Ling.
11. College Physics by Sears, Zemansky and Young.
12. Fundamentals of College Physics by Peter J Nolan.
13. Physics by Robert Hutchings.
14. Nuffield Physics by Geoffery Dorling.
15. Advanced level Physics by Nelkon and Parker.
16. Advanced Physics by T. Duncan.
17. Understanding Physics by Pople.
18. Fundamental of Physics by Tahir Hussain.
19. Physics for Advanced Level by Jim Breithhaupt.
20. College Physics by Vincent P. Coletta.
21. Physics by J.B. Marion.
22. Physics by Atam P. Arya.
23. Contemporary College Physics by E. R. Jones and R. L. Childers.
24. Physics by John D. Cutnell and Kenneth W. Johnson.
25. Physics by Kane and Sternhein.



## INDEX

<b>A</b>		Capacitance	22
A.C. generator	97-99	Capacitor	22
Absorbed dose	250	CAT Scanar	211
Alpha particles	226	Characteristic X-rays	209-210
Alternating current	111	Choke	123
Ammeter	74	Collector	159
Amorphous solid	136	Comparator	166-167
Ampere's law	61-62	Compressional stress	138
Amplitude modulation	131	Compressive strain	138
AND gate	168	Compton effect	190-191
AND Operation	168	Compton shift	190-191
Annihilation of matter	192-193	Compton wavelength	190-191
Atomic nucleus	220	Conductance	38
Atomic number	220	Conduction band	143
Avometer	76	Conductors	143-144
<b>B</b>		Conventional current	32
Balmer series	203	Core	244
Baryons	256	Coresivity	150
Base	159	Cosmic radiation	249
Basic forces	254-255	Coulomb's law	2
Becquerel	250	Critical mass	242-243
Beta particles	226	Critical temperature	146
Binding energy	223	Crystalline solid.	136
Black body	183	Curie	250
Black body radiation	182-183	Current gain	160
Bohr's atomic model	204-205	<b>D</b>	
Bohr's orbit	205	D.C. generator	100-101
Boolean variable	168	D.C. motor	102
Brackett series	204	Daughter element	230
Bragg's equation	194-195	Dead beat galvanometer	74
Bremsstrahlung	210	de-Broglie relation	193
Brittle substances	140	Decay constant	230
Building block of matter	255-256	Depeletion region	154
Bulk modulus	139	Deuterium	221
<b>C</b>		Deuteron	221
C.R.O.	68-70	Diamagnetic substances	148



Dielectric constant	24	<b>G</b>	
Digital multimeter	77-78	Gain	164-165
Digital system	167-168	Galvanometer	71-74
Domains	148-149	Gamma rays	226-227
Ductile substances	140	Geiger Muller counter	235-237
<b>E</b>		General theory of relativity	178
e.m.f.	43-44	Gray	251
Einstein photo electric equation	188	Guass's law	12
Elastic deformation	140	<b>H</b>	
Electric current	32	Hadrons	256
Electric field strength	7	Half life	229
Electric flux	9-10	Half wave rectification	156
Electric intensity	5	He-Ne laser	215
Electric polarization	24-25	Henry	92-94
Electric potential	15	Holography	216
Electromagnet	149	Hooke's law	140
Electromagnetic spectrum	185	Hydrogen emission spectrum	207-208
Electromagnetic waves	128-129	Hysteresis	150
Electron microscope	197	Hysteresis loop	148-150
Electron volt	19	Hysteresis loss	150
Emitter	159	<b>I</b>	
Energy band theory	143-144	Impedance	120
Energy density	96	Induced current	82-84
Energy-mass relation	180-181	Induced e.m.f.	82-84
Equivalent dose	251	Inertial frame of reference	177
Excitation potential	207	Insulators	143-144
Extrinsic semiconductor	144	Intrinsic semiconductor	144
<b>F</b>		Ionization energy	207
Farad	22	Ionization potential	207
Faraday's law	87	Isotopes	221
Fast reactor	246	<b>K</b>	
Ferromagnetic materials	148	Kirchhoff's first law	46
Fission chain reaction	242	Kirchhoff's second law	47
Fluorescence	233	<b>L</b>	
Forbidden energy gap	143	Laser	213
Forward resistance	155	Leakage current	155
Frame of reference	177	Length contraction	179
Frequency modulation	131-132	Lenz's law	88
Full wave rectification	157	Leptons	256
Fusion reaction	247	Light emitting diode	157



Linear absorption co-efficient	233	Operational amplifier	162-163
Lyman series	203	OR gate	168
<b>M</b>		OR operation	168
Magnetic dipole	148	<b>P</b>	
Magnetic flux	60	p - n junction	154
Magnetic flux density	60-61	Pair production	192
Mass defect	223	Parent element	227
Mass spectrograph	222-223	Paschen series	204
Mass variation	180	Pfund series	204
Measurement of e/m	66-67	Photo diode	158
Mesons	256	Photo electron	187
Millikan's method	20-21	Photo electron	187
Moderator	244	Photo voltaic cell	158
Modulation	131	Photocell	189
Modulus of elasticity	139	Photoelectric effect	187-189
Motional e.m.f.	84	Photon	185
Mutual inductance	90-91	Plancks constant	184
<b>N</b>		Plastic deformation	140
NAND gate	169	Plasticity	140
NAND operation	169	Polymeric solids	136-137
NAVASTAR Navigation system	180	Population inversion	214
NAVASTAR	180	Positron	192
Night switch	171	Potentiometer	51-52
Non-inertial frame of reference	178	Principle quantum number	204
NOR gate	169	Proportional limit	140
NOR operation	169	Protium	221
NOT gate	169	<b>Q</b>	
NOT operation	169	Quantized energy	206
n-p-n transistor	159	Quantized radii	206
Nuclear fission	240	Quarks	256
Nuclear power station	243-245	<b>R</b>	
Nuclear reaction	238-239	Radiation absorbed dose	251
Nuclear reactor	243-246	Radiation detector	234-237
Nuclear transmutation	227-228	Radiation exposure	249-250
Nucleon number	220	Radiation sickness	251
<b>O</b>		Radioactive decay	227
Ohm	37	Radioactive elements	226
Ohm meter	76-77	Radioactivity	226
Ohm's law	36	Radiography	254
Open loop gain	163	Rectification	156



Relative biological effectiveness	251
Relative motion	177
Rem	251
Resistivity	38
Resonance	125
Retentivity	150
Rheostat	41
Right hand rule	57
Rutherford atomic model	220
Rydberg constant	203, 208

### S

Saturation	150
Self inductance	93
Self quenching	236
Semiconductors	143
Sensors	170-171
Shear modulus	139
Shear strain	139
Shear stress	138
Sievert	251
Solid state detector	237
Special theory of relativity	178-181
Spectral series	203
Spectroscopy	202
Step down transformer	104
Step up transformer	104
Stephan Boltzmann's law	184
Stephan's constant	184
Stimulated absorption	213
Stimulated emission	213
Stopping potential	187
Strain	138
Stress	138
Stress-strain curve	140
Superconductor	146-147

### T

Tensile strain	138
Tensile stress	138
Thermal reactor	246
Thermistor	42
Threshold frequency	188
Time dilation	179
Tracer techniques	252-253
Transformer	103-106
Transistor	159
Tritium	221

### U

Ultimate tensile strength	140
Uncertainty principle	197-199
Unified mass	220
Uses of laser	215-216

### V

Voltage gain	101-162
Voltmeter	75
Volumetric strain	138-139

### W

Wave particle duality	195-196
Weber	60
Wheatstone bridge	50-51
Wilson cloud chamber	234-235
Work function	188

### X

Xerography	8-9
XNOR gate	170
XNOR operation	170
XOR gate	169-170
XOR operation	169
X-rays	209-211

### Y

Young's modulus	139
-----------------	-----